

INVERTED TOOTH

Chains and Sprockets



FOR POWER TRANSMISSION



Ramsey Products
CORPORATION

Ramsey Silent Chains

For Power Transmission

Ramsey Products specializes in the design, manufacture, and application of silent chain drives, also known as inverted tooth or toothed chain drives. For more than 80 years this has been our focus, and today we remain committed to providing our customers with the world's widest range of top quality silent chain products.

Because we specialize in silent chain, we understand how important it is to choose the right chain and sprockets for each application. Whether selecting components for a new application, replacing an existing chain, or custom designing a chain, our goal is to provide our customers with the most practical and cost effective solutions. If a job can be done with silent chain, we will help find the best chain for the job, at the lowest possible cost.

Many companies sell silent chain, but no one offers the product range, quality, and support provided by Ramsey. In addition to our extensive standard product line, we offer replacements for most competitors' chains, as well as custom designed chains. We also provide free consultation and drive selection assistance through our staff of experienced designers. Whether your requirement is a single chain, or a much larger volume, our sales and engineering staff has the experience to assist you. With warehouses and representatives around the world, we welcome the opportunity to serve you.

ABOUT THIS CATALOG

Ramsey manufactures three different silent chain product lines for general power transmission. Each has unique features and advantages:

RPV series

RPV chain and sprockets are high performance products offering maximum speed and power handling capability. RPV is usually the choice for challenging applications, particularly where space is limited and power or speed requirements exceed the capacity of other products.

RP series

RP or RamPower silent chain provides approximately two times the power capacity of standard silent chain. RP chain operates on sprockets having an ASME Standard tooth profile and is well suited for new or replacement applications.

SC series

SC silent chain and sprockets are manufactured to comply with the ASME Standard for silent chain. SC products have been around the longest, are used primarily in replacement applications, and are often the most economical.



Many of the products listed in this catalog are successfully employed in applications other than power transmission. For additional information regarding other silent chain applications, such as conveying, or for details on specialty silent chain products, please call Ramsey or visit our website: www.ramseychain.com.

CONTENTS

Silent Chain Fundamentals.....	2-3
Applications.....	4
RPV.....	5-7
RP.....	8-10
SC.....	11-14
Sprockets.....	15-21

Ordering Information.....	22
Drive Selection.....	23-25
Lubrication.....	26-27
Installation.....	28
Connection.....	29
Service Factors.....	30
Maintenance and formulas.....	31

WHY SILENT CHAIN?

Silent chain offers today's drive designer unique advantages and options for transmitting power smoothly, efficiently, and economically. Capable of transmitting loads and speeds that exceed the capacity of all other chains and belts, silent chain provides proven technology that is found in applications throughout modern industry. Silent chain also produces very little vibration or noise, and operates at efficiencies as high as 99%. Add to these features a wide range of standard chain and sprocket sizes and the result is an extremely flexible and powerful system for power transmission.

Silent Chain Drives compared with belts

1. Significantly higher speeds and power capacity
2. Greater efficiency
3. Larger ratios possible
4. No slippage
5. Withstands heavier overloads
6. Higher drive ratios at short center distances
7. Less affected by temperature or humidity
8. Lower bearing loads
9. Detachable and therefore more easily installed
10. Effective in oil filled gear boxes

Silent Chain Drives compared with roller chain

1. Significantly higher speeds and power capacity
2. Much quieter
3. Transmits power more smoothly, less vibration
4. Lower impact load during sprocket engagement
5. Higher efficiency (as high as 99%)
6. Longer sprocket life

Silent Chain Drives compared with gears

1. Quieter than spur gears
2. Center distance much less restricted
3. Shaft parallelism tolerances are broader
4. Lower bearing loads
5. No end thrust as with helical gears
6. Greater elasticity to absorb shock

CHAIN CONSTRUCTION

Ramsey silent chains are made from hardened alloy steel components consisting of flat tooth shaped driving links, guide links and pins that form the chain joint. The driving links engage sprocket teeth much the way a rack and pinion mesh. Guide links serve to retain the chain on sprockets and pins hold the joint together and allow the chain to flex.

Driving Links

Driving links, also known as plain links, engage sprocket teeth with less sliding and less impact than other types of chain. This results in quieter operation and longer sprocket life. Reduced impact loading also allows for higher operating speeds.



Guide Links

Guide links maintain proper tracking of the chain on sprockets. They can be positioned on the outer edges of the chain in side guide or nearer to the middle of the chain with center guide. Wider chains will often have two rows of center guide links, commonly referred to as two center guide.



Pins and Joints

RPV, RP, and SC chains use highly specialized two-pin joints that have been developed to maximize chain load and speed capacity, while reducing friction and wear. RPV and RP use case hardened "crescent" shaped pins, while SC chains contain the original "D" shaped Ramsey pin profile, also case hardened for maximum wear resistance. The one exception is SC 3/16" pitch chain, which due to relatively light loading, is produced with a single pin joint.



RPV and RP chain joint with "Crescent" shaped pins



SC chain joint with "D" shaped pins

Silent Chain Fundamentals

HOW TWO PIN JOINTS WORK

This figure shows how the Ramsey two pin joint works. As a chain engages the sprocket, and moves from position A to position B, the convex surfaced pins roll upon one another. This rolling action eliminates the sliding friction and galling that occurs in other types of chain. Pin action also minimizes the effects of chordal action by slightly increasing chain pitch and internally moving the pitch point up to coincide with the sprockets pitch circle. As a result, the chain smoothly and efficiently engages the sprocket, very nearly tangent to the pitch circle. The smoothness and lack of vibration results in a quiet drive with higher load and speed capability.

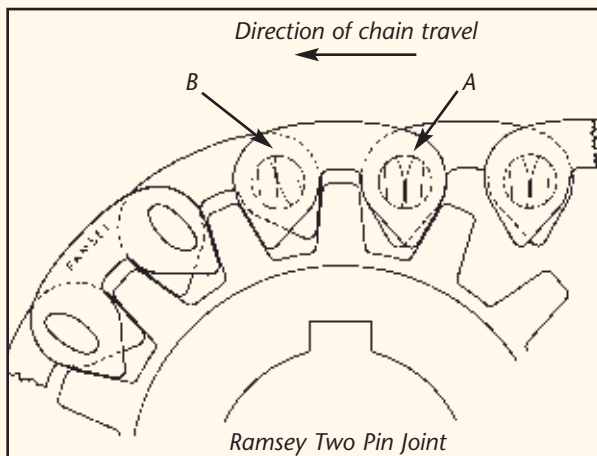

A Ramsey Silent Chain operating at high speed. Note the smoothness and lack of vibration

Chain Guide Type

Chain guide type describes the placement of guide links within the chain. The most common guide types are, one center guide, two center guide, and side guide .

One Center Guide

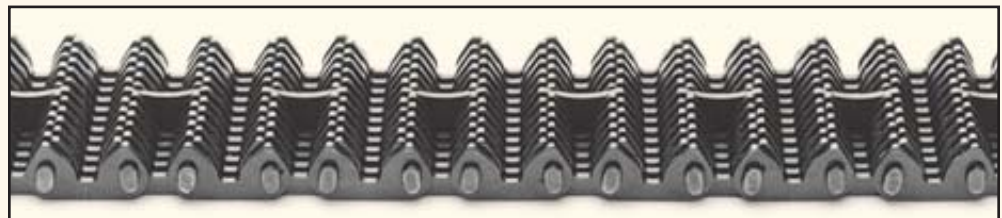

Two Center Guide

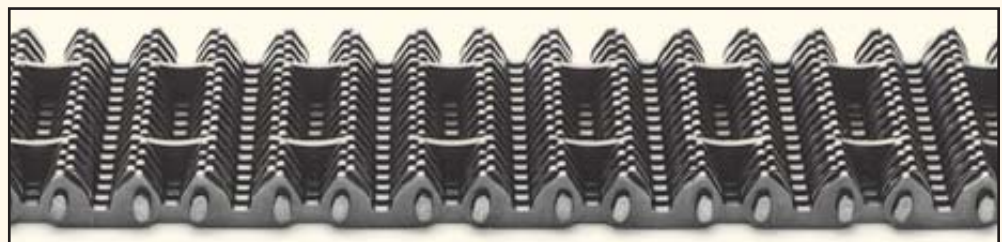

Side Guide

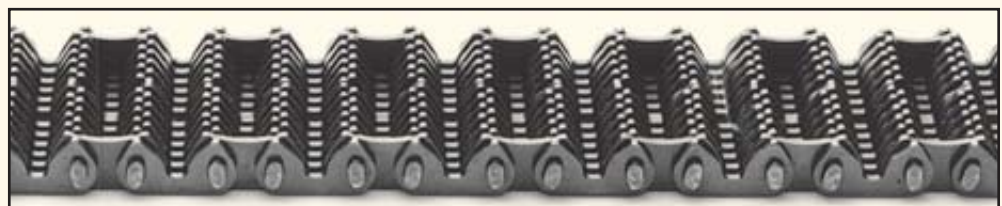

Applications

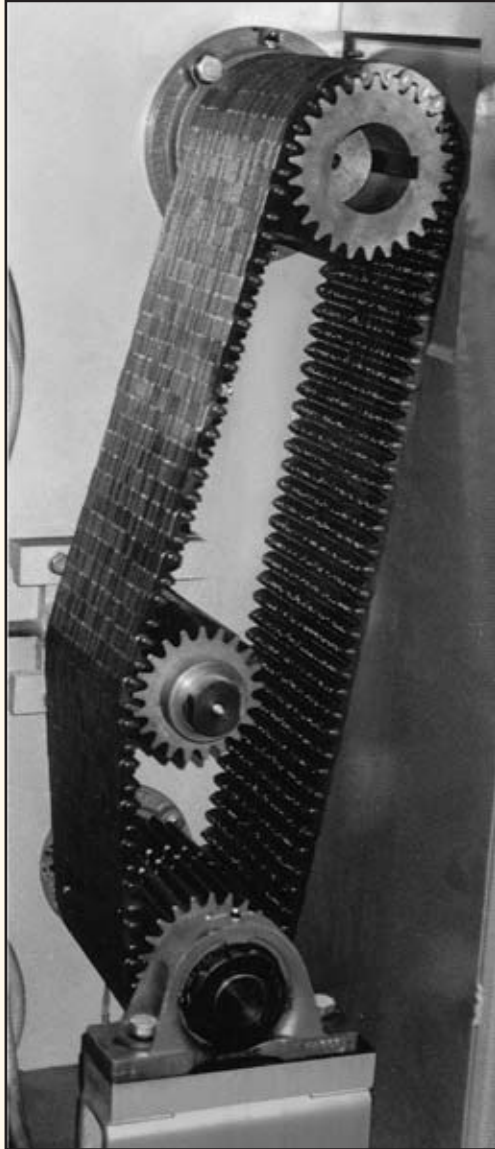

Main drive on plastic film extruder



Paddle wheel drive on a large river boat

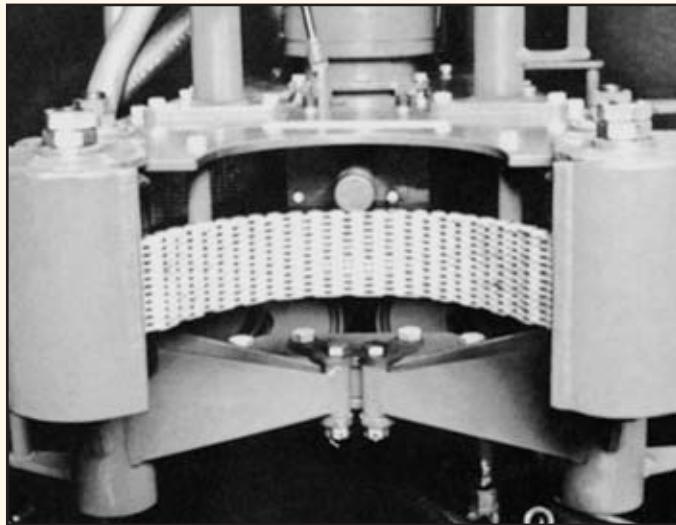

Pipe spinner on oil drilling rig

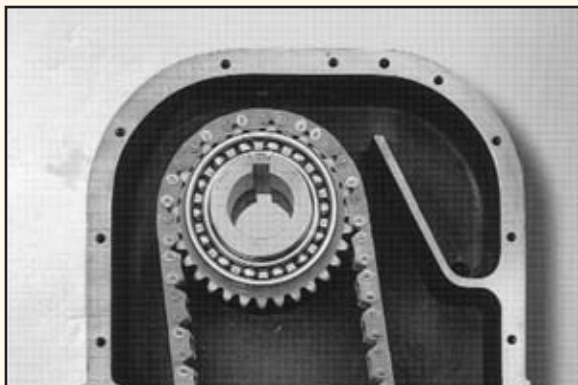

Diesel powered highway snow blower

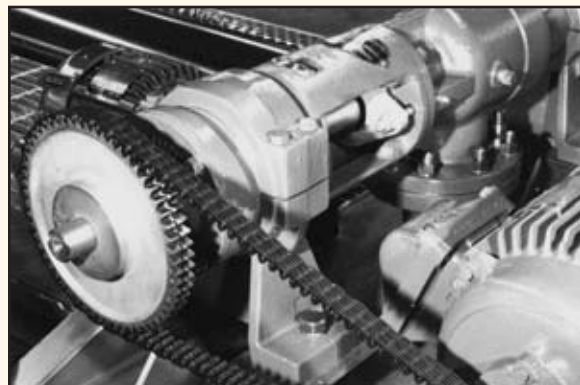

Floating oil scavenger pump

RPV SERIES CHAIN

RPV is high performance inverted tooth chain, specifically designed to meet or exceed the capability of all other high performance chains. RPV is capable of speeds in excess of 35 m/s and loads exceeding 2200 kw.

RPV's strength and load capacity comes from improved link and sprocket designs. Links are designed to minimize stress concentrations and to increase the amount of steel in the line of chain pull. Innovative stamping methods maximize the amount of load bearing surface in each link and greatly reduce the rate of chain elongation during operation. All links are shot peened to improve fatigue strength and produce a uniform, high quality finish.

RPV sprockets employ an involute tooth profile to decrease impact loading and vibration during chain engagement. RPV chain engages sprockets nearly tangent to the sprocket pitch circle, reducing the velocity variation produced by chordal action. Reduced velocity variation creates less vibration and translates directly to less wasted energy and higher load carrying capacity.

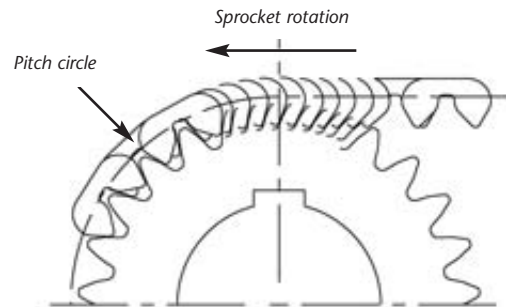
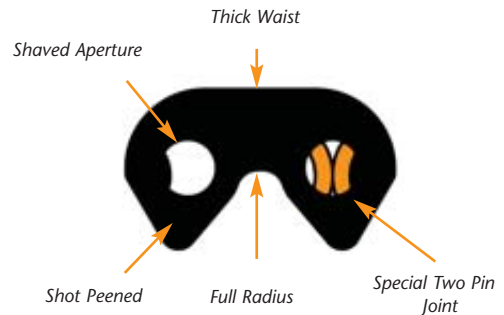

The
...RPV
...Advantage

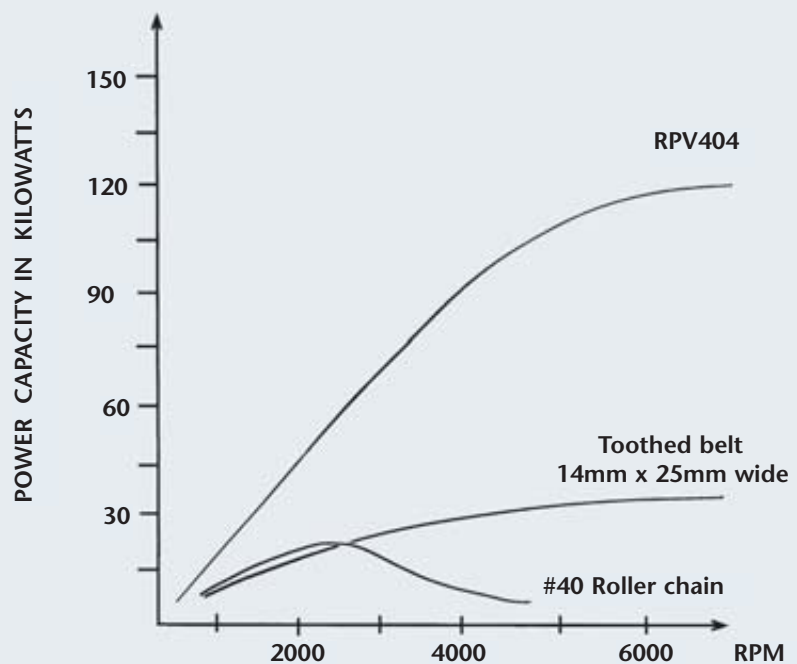

Power ratings are based on 33 tooth sprockets

RPV Side Guide Assemblies

3/8" through 1" Pitch

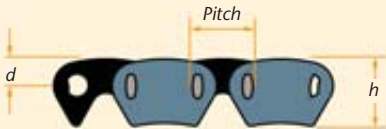

Type 139



1 1/2" and 2" Pitch

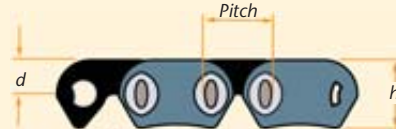

Type 115



Pitch	Part Number	Nominal Width	Width Between Guides WBG	Width Over Heads WH	Width Over Links WL	Width At Connector WC	Weight (kg/m)	Breaking Load (kN)	h	d	t
3/8"	RPV303	19	17.5	22.9	20.6	26.2	1.0	27	10.9	4.3	1.5
	RPV304	25	23.6	29.2	26.7	32.5	1.3	36			
	RPV306	38	36.3	41.9	39.4	45.5	1.9	53			
	RPV308	51	49.0	54.9	52.1	58.2	2.7	71			
	RPV312	76	74.4	80.3	77.5	83.6	3.9	107			
1/2"	RPV404	25	23.6	29.2	26.7	32.5	1.8	49	14.5	5.8	1.5
	RPV406	38	36.3	41.9	39.4	45.2	2.7	73			
	RPV408	51	49.0	54.9	52.1	58.2	3.6	98			
	RPV412	76	74.4	80.3	77.5	83.6	5.2	147			
	RPV416	102	99.8	105.7	102.9	109.0	7.0	196			
3/4"	RPV606	38	36.3	45.0	41.4	48.5	4.6	110	21.6	8.6	2.0
	RPV608	51	49.0	58.7	54.4	62.2	5.5	147			
	RPV612	76	74.4	84.1	79.8	87.6	7.9	220			
	RPV616	102	99.8	109.5	105.2	113.0	10.4	294			
	RPV620	127	125.2	134.9	130.6	138.4	12.9	367			
1"	RPV808	51	48.0	61.0	56.6	63.8	7.4	196	29.0	11.4	3.0
	RPV812	76	73.4	86.4	82.0	89.2	10.7	294			
	RPV816	102	98.8	111.8	107.4	114.6	14.1	391			
	RPV820	127	124.2	137.2	132.8	140.0	17.4	489			
	RPV824	152	149.6	162.6	158.2	165.4	21.0	587			
1-1/2"	RPV1212	76	64.3	84.3	70.4	85.1	15.5	440	41.9	20.6	3.0
	RPV1216	102	89.7	109.7	95.8	110.5	20.5	587			
	RPV1220	127	115.1	135.1	121.2	135.9	25.7	734			
	RPV1224	152	140.5	160.5	146.6	161.3	30.8	881			
2"	RPV1616	102	85.5	111.8	93.6	112.3	27.4	783	55.6	27.4	4.1
	RPV1620	127	110.9	137.2	119.0	137.7	34.2	979			
	RPV1624	152	136.3	162.6	114.4	163.1	41.1	1174			
	RPV1632	203	187.1	213.4	195.2	213.9	54.8	1566			

Other chain widths are available
 Unless indicated, all dimensions are in millimeters
 3/4" and 1" pitch is also available in Type 115 link style

RPV

Center Guide Assemblies

RPV Center Guide Assemblies

3/8" and 1/2" Pitch

Type 139



3/4" through 2" Pitch

Type 115

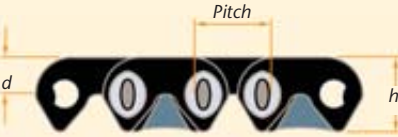

Pitch	Part Number	Nominal Width	Width Over Heads WH	Width Over Links WL	Width At Connector WC	Weight (Lbs/ft)	Breaking Load (Lbf)	h	d	t
3/8"	RPV3-025	25	32.5	27.2	33.8	1.5	36	10.9	4.3	1.5
	RPV3-030	30	38.6	33.5	40.1	1.8	43			
	RPV3-040	41	45.2	40.1	46.7	2.1	57			
	RPV3-050	51	57.7	52.6	59.7	2.8	71			
	RPV3-065	66	70.1	65.0	72.1	3.4	93			
1/2"	RPV4-325	25	33.0	27.7	35.6	1.9	49	14.5	5.8	1.5
	RPV4-330	30	39.1	34.0	41.4	2.4	59			
	RPV4-340	41	46.2	40.6	47.8	2.8	78			
	RPV4-350	51	58.7	53.1	60.2	3.7	98			
	RPV4-365	66	70.6	66.0	72.4	4.5	127			
	RPV4-375	76	84.6	79.2	86.4	5.4	147			
	RPV4-3100	99	109.2	105.2	111.3	7.0	191			
3/4"	RPV6-535	36	43.2	35.1	46.5	3.9	103	21.1	10.4	2.0
	RPV6-540	41	50.0	43.7	53.6	4.8	117			
	RPV6-550	51	58.7	51.6	62.0	5.5	147			
	RPV6-565	66	75.7	68.1	78.7	7.1	191			
	RPV6-585	86	92.7	84.6	94.2	8.9	250			
	RPV6-5100	99	109.2	101.1	111.5	10.6	286			
1"	RPV8-640	41	51.1	41.7	54.1	6.0	157	27.9	13.7	3.0
	RPV8-650	51	61.7	54.1	65.3	7.6	196			
	RPV8-665	66	74.7	67.1	78.0	9.4	254			
	RPV8-675	76	87.6	79.5	90.7	11.0	294			
	RPV8-6100	99	112.5	105.2	115.8	14.4	382			
	RPV8-6125	124	138.2	130.6	141.5	17.9	479			
	RPV8-6150	150	163.6	156.2	166.9	21.3	577			

Other chain widths are available

Unless indicated, all dimensions are in millimeters

3/4" and 1" pitch is also available in Type 139 link style

RP SERIES CHAIN

RP or RamPower series silent chain was designed to operate on sprockets manufactured with an ASME Standard tooth profile. Available exclusively through Ramsey, RamPower offers twice the power capacity of SC series chains and speeds up to 35 m/s. RamPower has been successfully employed in applications transmitting up to 1850 kw and is often preferred where high loads and speeds must be accommodated in a small amount of space.

The increased load carrying capacity of RamPower is a result of improved link and pin designs. Working with independent laboratories, Ramsey engineers re-designed the standard SC link shape to reduce stress concentrations, improve fatigue life, and increase link tensile strength. Innovative stamping methods were also employed to maximize the amount of bearing surface area in each link. The increased bearing area produces less stress in the chain joint and greatly reduces the rate of chain elongation during operation. All chain links are shot peened to improve fatigue resistance and produce a uniform finish.

In most applications RamPower will experience very little initial elongation, making it well suited for fixed center drive applications. We recommend RamPower for all new chain drives where the customer desires to use sprockets with the ASME standard tooth profile. It is also well suited for upgrading existing SC chain applications when improved performance is desired.

RamPower is available in center guide as well as side guide assemblies.

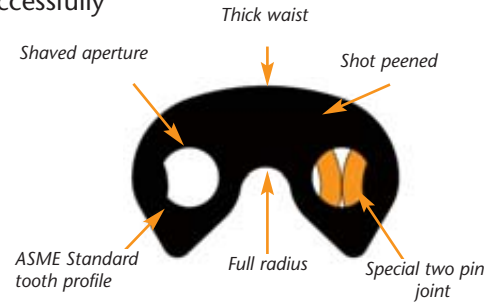

Cross section of an RP link aperture

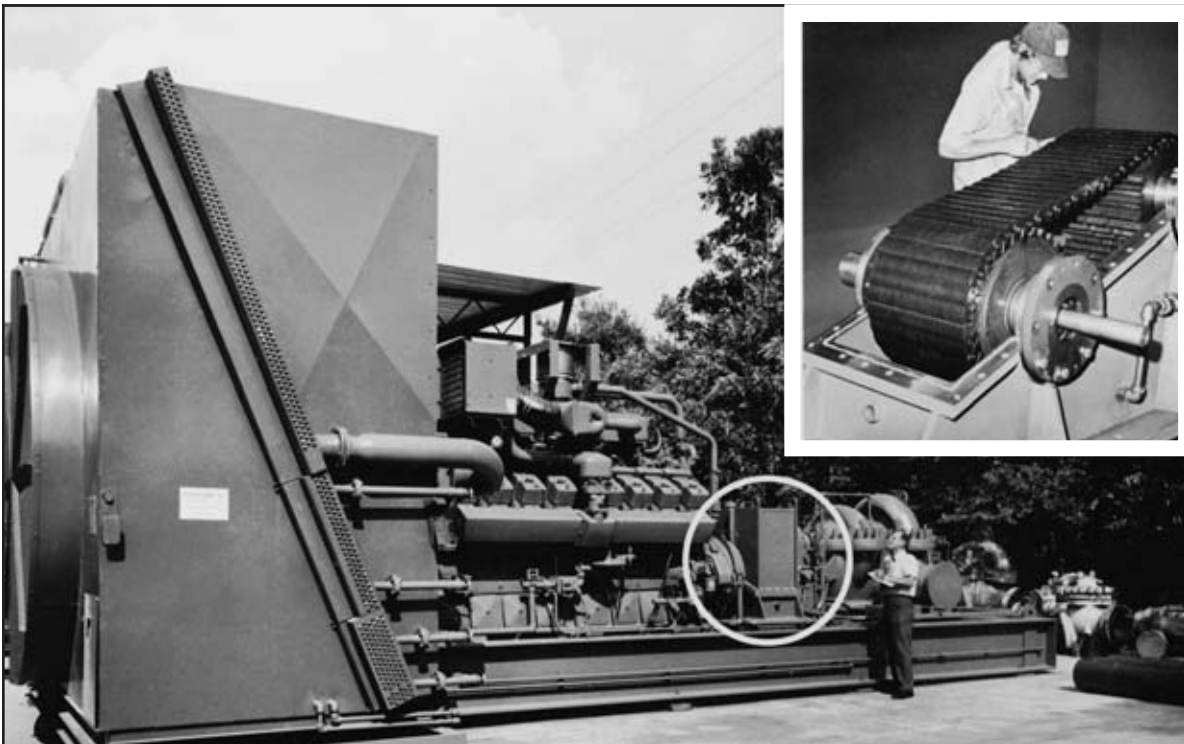
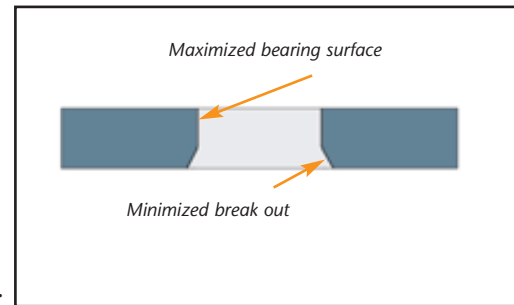

Rampower drive in oil field pump

RP Center Guide Assemblies

3/8" and 1/2" Pitch

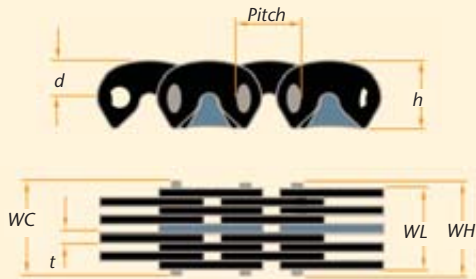

5/8" through 2" Pitch

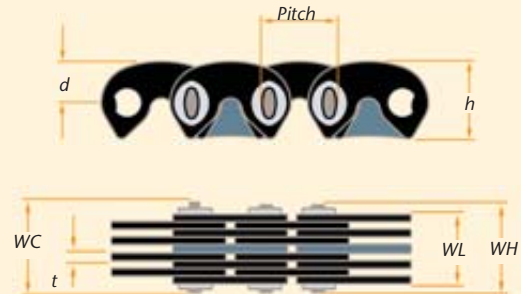

Pitch	Part Number	Nominal Width	Guide Type	Width Over Heads WH	Width Over Links WL	Width At Connector WC	Weight (kg/m)	Breaking Load (kN)	h	d	t
3/8"	RP302	13	CG	16.3	13.5	17.5	0.7	17	10.7	5.6	1.5
	RP303	19	CG	22.6	19.6	23.9	1.0	25			
	RP304	25	CG	29.0	25.7	30.5	1.3	33			
	RP305	32	CG	35.3	31.8	36.8	1.6	42			
	RP306	38	CG	41.7	37.6	43.2	2.1	50			
	RP308	51	CG	54.4	49.8	55.9	2.5	67			
	RP310	64	CG	67.1	62.0	68.8	3.3	83			
	RP312	76	2CG	79.2	73.9	81.5	3.7	100			
	RP316	102	2CG	104.6	98.0	107.2	5.1	133			
1/2"	RP403	19	CG	23.9	19.8	25.4	1.2	33	14.2	7.6	1.5
	RP404	25	CG	30.0	25.9	32.3	1.6	44			
	RP405	32	CG	36.3	32.3	38.1	2.1	56			
	RP406	38	CG	42.7	38.4	44.5	2.4	67			
	RP408	51	CG	55.4	50.5	57.2	3.3	89			
	RP410	64	CG	68.1	63.0	70.1	4.0	111			
	RP412	76	CG	81.8	75.2	82.8	4.9	133			
	RP414	89	CG	93.7	87.6	95.5	5.7	156			
	RP416	102	2CG	106.4	99.8	108.2	6.5	178			
	RP420	127	2CG	132.1	124.5	133.9	8.2	222			
	RP424	152	2CG	156.5	148.8	158.8	9.7	267			
	5/8"	RP504	25	CG	33.5	25.7	35.6	2.7			
RP506		38	CG	46.2	37.6	48.3	3.4	83			
RP508		51	CG	58.4	49.5	60.5	4.5	111			
RP510		64	CG	70.1	61.5	72.1	4.6	139			
RP512		76	CG	82.6	73.2	84.6	7.1	167			
RP514		89	CG	94.7	85.1	96.8	7.9	195			
RP516		102	CG	107.2	97.0	83.8	8.9	222			
RP520		127	CG	131.6	120.7	133.6	11.3	278			
RP524		152	CG	157.0	144.5	159.0	13.4	334			

Other chain widths are available
 Unless indicated, all dimensions are in millimeters

RP Center Guide Assemblies

Pitch	Part Number	Nominal Width	Guide Type	Width Over Heads WH	Width Over Links WL	Width At Connector WC	Weight (ka/m)	Breaking Load (kN)	h	d	t
3/4"	RP604	25	CG	33.5	25.7	35.6	2.7	66.7	21.3	10.9	2.0
	RP606	38	CG	46.2	37.6	48.3	3.9	100			
	RP608	51	CG	58.4	49.5	60.5	5.2	133			
	RP610	64	CG	71.1	61.5	73.2	6.5	167			
	RP611	70	CG	75.2	65.3	77.2	7.1	183			
	RP612	76	CG	81.5	73.2	83.6	7.9	200			
	RP616	102	CG	106.9	97.0	109.0	10.4	267			
	RP620	127	CG	131.6	120.7	133.6	13.1	334			
	RP624	152	CG	159.0	144.5	161.0	15.6	400			
	RP628	178	CG	184.4	168.4	186.4	18.3	467			
RP632	203	CG	207.0	192.0	209.0	20.8	534				
1"	RP808	51	CG	57.4	45.5	60.2	6.2	178	28.4	15.2	3.0
	RP812	76	CG	81.0	69.3	85.1	9.4	267			
	RP816	102	CG	107.4	93.0	110.2	12.5	356			
	RP820	127	CG	131.6	116.8	134.4	15.6	445			
	RP824	152	CG	156.0	140.5	159.8	18.7	534			
	RP828	178	CG	188.7	170.2	191.5	21.9	623			
	RP832	203	CG	213.6	196.1	216.4	25.0	712			
	RP836	229	CG	234.7	217.9	237.5	28.1	801			
	RP840	254	CG	263.7	241.6	266.4	31.2	890			
RP848	305	CG	316.0	293.1	319.0	37.5	1068				
1-1/2"	RP1212	76	CG	84.3	72.9	84.3	14.0	400	42.7	22.9	3.0
	RP1216	102	CG	108.7	98.3	108.7	18.3	534			
	RP1220	127	CG	131.6	121.2	131.6	22.9	667			
	RP1224	152	CG	159.5	149.1	159.5	27.5	801			
	RP1228	178	CG	184.9	175.0	184.9	32.0	934			
	RP1232	203	CG	210.6	200.7	210.6	36.6	1068			
	RP1236	229	CG	236.7	226.6	236.7	39.1	1201			
	RP1240	254	CG	264.7	254.0	264.7	45.8	1334			
2"	RP1616	102	CG	110.2	93.2	110.2	24.4	712	57.2	30.5	3.0
	RP1620	127	CG	135.6	117.3	135.6	30.5	890			
	RP1624	152	CG	161.0	141.2	161.0	36.6	1068			
	RP1628	178	CG	186.4	165.4	186.4	42.7	1245			
	RP1632	203	2CG	211.8	189.5	211.8	48.8	1423			
	RP1640	254	2CG	262.6	237.7	262.6	61.0	1779			
	RP1648	305	2CG	313.4	285.8	313.4	73.2	2135			
	RP1656	356	2CG	370.6	340.1	370.6	85.4	2491			
RP1664	406	2CG	421.4	382.0	421.4	97.6	2847				

Other chain widths are available

Unless indicated, all dimensions are in millimeters

SC

Industry Standard Silent Chain

SC SERIES

SC series chain is available in center guide and side guide assemblies. Center guide assemblies are fully compliant with the ASME Standard for silent chain. Both side guide and center guide operate on industry standard sprockets.

SC chain can accommodate speeds approaching 33 m/s and loads in excess of 750 kw. Utilizing the patented Ramsey roller bearing joint, SC chain is Ramsey's most popular industrial chain.

We recommend SC chain primarily as a replacement chain for existing power transmission applications where it has been successfully employed in the past. SC chain weighs less than an equal width of RPV or RP chain, and it typically costs less.

SC Center Guide Assemblies



One Center Guide



Two Center Guide



Pitch	Part Number	Nominal Width	Guide Type	Width Over Heads WH	Width Over Links WL	Width At Connector WC	Weight (kg/m)	Breaking Load (kN)	h	d	t
3/8"	SC302	13	SG	13.2	10.4	14.5	0.6	9	9.4	4.6	1.5
	SC303	19	CG	19.6	16.5	20.8	0.7	13			
	SC304	25	CG	25.9	22.6	27.4	1.0	18			
	SC305	32	CG	32.3	28.7	33.8	1.3	22			
	SC306	38	CG	38.6	34.5	40.1	1.6	26			
	SC310	64	CG	64.0	58.9	65.8	2.7	44			
	SC312	76	2CG	76.2	70.9	78.5	3.1	53			
	SC316	102	2CG	101.6	95.0	104.1	4.2	70			
1/2"	SC402	13	SG	14.0	10.7	16.0	0.7	12	11.9	5.3	1.5
	SC403	19	CG	20.6	16.8	22.4	1.0	18			
	SC404	25	CG	26.9	22.9	28.7	1.3	23			
	SC405	32	CG	33.3	29.0	35.1	1.6	29			
	SC406	38	CG	39.6	35.3	41.4	2.1	35			
	SC408	51	CG	52.3	47.5	54.1	2.7	47			
	SC410	64	CG	65.0	59.7	66.8	3.4	58			
	SC412	76	CG	78.0	72.1	79.8	4.0	70			
	SC414	89	CG	90.7	84.3	92.5	4.8	82			
	SC416	102	2CG	103.4	96.8	105.2	5.4	93			
	SC420	127	2CG	129.0	121.2	130.8	6.7	117			
	SC424	152	2CG	154.7	145.8	156.5	8.0	140			
SC428	178	2CG	180.1	170.4	181.9	9.4	163				

SC Center Guide Assemblies

Pitch	Part Number	Nominal Width	Guide Type	Width Over Heads WH	Width Over Links WL	Width At Connector WC	Weight (kg/m)	Breaking Load (kN)	h	d	t
5/8"	SC504	25	CG	30.7	25.7	32.5	1.8	27.8	16.5	8.4	20.3
	SC506	38	CG	39.1	33.8	40.9	2.7	42			
	SC508	51	CG	51.6	45.5	53.3	3.6	56			
	SC510	64	CG	64.3	57.4	66.0	4.5	69			
	SC512	76	CG	76.7	69.3	78.5	5.4	83			
	SC516	102	CG	101.9	93.2	103.6	7.1	111			
	SC520	127	2CG	127.0	116.8	128.8	8.9	139			
	SC524	152	2CG	152.1	140.7	153.9	10.7	167			
SC532	203	2CG	206.8	192.0	208.5	14.3	222				
3/4"	SC604	25	CG	31.0	25.7	34.3	2.2	35	20.3	10.4	20.3
	SC606	38	CG	39.9	33.8	42.7	3.4	53			
	SC608	51	CG	52.1	45.5	55.4	4.5	70			
	SC610	64	CG	64.5	57.4	67.8	5.7	88			
	SC612	76	CG	77.2	69.3	80.5	6.7	105			
	SC616	102	CG	102.4	93.0	105.7	8.9	140			
	SC620	127	CG	127.5	116.8	130.8	11.2	175			
	SC624	152	CG	152.7	140.7	156.0	13.4	210			
	SC628	178	2CG	181.9	168.4	185.2	15.6	245			
	SC632	203	2CG	207.0	192.0	210.3	17.9	280			
1"	SC808	51	CG	52.3	45.2	55.1	5.4	93	24.9	12.2	3.0
	SC812	76	CG	77.5	69.1	80.5	8.0	140			
	SC816	102	CG	102.6	93.2	105.7	10.7	187			
	SC820	127	CG	127.8	117.3	130.8	13.4	234			
	SC824	152	CG	153.7	141.2	156.5	16.1	280			
	SC828	178	2CG	178.8	165.4	181.9	18.7	327			
	SC832	203	2CG	204.2	189.5	207.3	21.4	374			
	SC836	229	2CG	229.4	213.6	232.4	24.1	420			
	SC840	254	2CG	254.8	237.7	257.8	26.8	467			
	SC848	305	2CG	305.3	285.8	308.4	32.1	560			
1-1/2"	SC1212	76	CG	84.8	69.1	84.8	13.4	210	38.1	18.0	3.0
	SC1216	102	CG	110.2	93.2	110.2	17.9	280			
	SC1220	127	CG	135.6	117.3	135.6	22.3	350			
	SC1224	152	CG	161.0	141.2	161.0	26.8	420			
	SC1228	178	CG	186.4	165.4	186.4	31.2	490			
	SC1232	203	2CG	211.8	189.5	211.8	35.7	560			
	SC1236	229	2CG	237.2	213.6	237.2	40.2	631			
	SC1240	254	2CG	262.6	237.7	262.6	44.6	701			
	SC1248	305	2CG	313.4	285.8	313.4	53.6	841			
	SC1256	356	2CG	370.6	340.1	370.6	62.5	981			
	SC1264	406	2CG	421.4	388.1	388.1	71.4	1121			

Other chain widths are available
 Unless indicated, all dimensions are in millimeters

SC

Side Guide Assemblies

SC Side Guide Assemblies

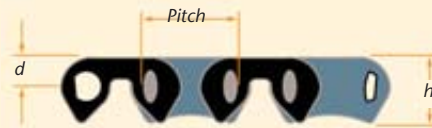

	Part Number	Nominal Width	Width Between Guides WBG	Width Over Heads WH	Width Over Links WL	Width At Connector WC	Weight (kg/m)	Breaking Load (kN)	h	d	t
3/8"	DSG302	13	6.4	14.7	12.2	16.0	0.6	9	9.4	4.6	1.5
	DSG303	19	12.7	21.3	18.0	22.6	0.9	13			
	DSG304	25	19.1	27.7	24.1	29.2	1.2	18			
	DSG305	32	25.4	34.0	30.2	35.6	1.3	22			
	DSG306	38	31.8	40.4	36.3	41.9	1.6	26			
	DSG308	51	44.5	53.1	48.3	54.6	2.5	35			
	DSG310	64	57.2	65.5	60.5	67.3	2.8	44			
	DSG312	76	69.9	78.5	72.6	80.3	3.3	53			
DSG316	102	95.3	104.1	96.8	105.7	4.9	70				
1/2"	DSG402	13	6.4	15.7	12.2	17.3	0.7	12	11.9	5.3	1.5
	DSG403	19	12.7	22.1	18.5	23.9	1.2	18			
	DSG404	25	19.1	28.4	24.6	30.2	1.5	23			
	DSG405	32	25.4	35.1	30.7	36.8	1.8	29			
	DSG406	38	31.8	41.4	36.8	43.2	2.2	35			
	DSG408	51	44.5	53.8	49.3	55.6	3.0	47			
	DSG410	64	57.2	66.8	61.5	68.3	3.7	58			
	DSG412	76	69.9	79.5	73.7	81.3	4.3	70			
DSG416	102	95.3	105.2	92.2	106.9	5.8	93				
5/8"	DSG504	25	19.1	30.7	25.7	32.5	1.8	29	16.5	8.4	20.3
	DSG506	38	31.8	43.2	37.6	45.0	2.7	44			
	DSG508	51	44.5	57.9	51.6	59.7	3.7	58			
	DSG510	64	57.2	70.4	63.5	72.1	4.6	73			
	DSG512	76	69.9	83.1	75.2	84.8	5.5	88			
	DSG514	89	82.6	95.5	87.1	97.3	6.4	102			
	DSG516	102	95.3	110.2	101.1	112.0	7.3	117			
	DSG520	127	120.7	135.4	124.7	137.2	9.1	146			
3/4"	DSG606	38	25.4	39.4	33.8	42.7	3.3	53	20.3	10.4	20.3
	DSG608	51	38.1	52.1	45.5	55.4	4.3	70			
	DSG610	64	50.8	64.5	57.4	67.8	5.5	88			
	DSG612	76	63.5	77.2	69.3	80.5	6.5	105			
	DSG614	89	76.2	89.7	81.3	93.0	7.6	123			
	DSG616	102	88.9	102.4	93.2	105.7	8.8	140			
	DSG620	127	114.3	127.5	116.8	130.8	11.0	175			
	DSG624	152	139.7	152.7	140.7	156.0	13.1	210			
DSG628	178	165.1	181.9	168.4	185.2	15.3	245				

Other chain widths are available
 Unless indicated, all dimensions are in millimeters

SC Side Guide Assemblies

Pitch	Part Number	Nominal Width	Width Between Guides WBG	Width Over Heads WH	Width Over Links WL	Width At Connector WC	Weight (kg/m)	Breaking Load (kN)	h	d	t
1"	DSG808	2	1 1/2	2.18	1.90	2.30	3.9	21,000	0.98	0.48	0.12
	DSG810	2 1/2	2	2.68	2.37	2.79	4.8	26,250			
	DSG812	3	2 1/2	3.17	2.84	3.29	5.9	31,500			
	DSG816	4	3 1/2	4.29	3.91	4.41	7.8	42,000			
	DSG820	5	4 1/2	5.28	4.86	5.40	9.8	52,500			
	DSG824	6	5 1/2	6.30	5.81	6.41	11.7	63,000			
	DSG828	7	6 1/2	7.42	6.87	7.53	13.7	73,500			
	DSG832	8	7 1/2	8.41	7.82	8.53	15.7	84,000			

SC 3/16" PITCH CHAIN

Ramsey 3/16" pitch chain is manufactured to ASME standards and will operate on standard sprockets. Chains are made entirely of 304 stainless steel and are available in side guide or center guide assemblies, depending on chain width.

SC 3/16" Pitch Chain

Center Guide

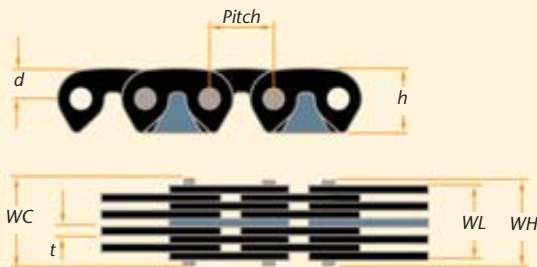

Side Guide

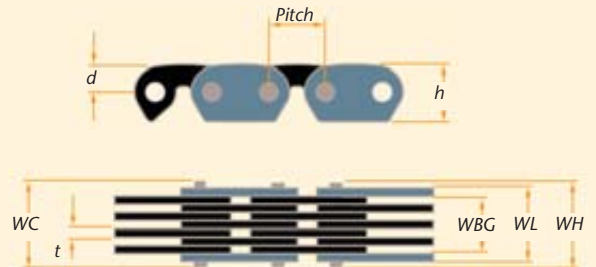

Pitch	Part Number	Nominal Width	Guide Type	Width Between Guides WBG	Width Over Heads WH	Width Over Links WL	Width At Connector WC	Weight (g/m)	h	d	t
3/16"	SC0305	4	SG	2.4	5.3	3.8	3.8	112	5.1	2.5	0.8
	SC0307	6	SG	4.0	7.1	5.3	5.3	149			
	SC0309	7	SG	5.6	8.9	6.9	6.9	177			
	SC0311	.9	SG	7.1	10.2	8.4	8.4	223			
	SC0315	12	SG	10.3	13.2	11.4	11.4	298			
	SC0315A	12	CG	25.4	13.2	11.4	11.4	298			
	SC0319	.15	CG	25.4	16.0	14.5	14.5	400			
	SC0319A	15	SG	13.5	16.0	14.5	14.5	400			
	SC0325	20	CG	25.4	21.3	19.1	19.1	502			
	SC0325A	20	SG	18.3	21.3	19.1	19.1	502			
	SC0331	20	CG	25.4	26.9	23.6	23.6	623			

Sprockets

Ramsey offers a full range of stock and made to order sprockets. Because they are produced in larger quantities, stock sprockets are often the most economical choice. Made to order sprockets provide a wider range of drive ratio options and are a large part of our daily production.

All sprockets can be fully machined to your specifications or you can request they be supplied with an unfinished bore to allow secondary machining. Ramsey also supplies sprockets to replace most competitors' products. We welcome all inquiries.

Materials

RPV, RP and SC sprockets are typically made from carbon steel or ductile iron, with sprocket teeth hardened to Rockwell hardness of Rc 50. For RP and SC only, some sprocket sizes are available in class 30 gray iron with unhardened teeth. Other materials are available subject to customer preference, sprocket size, cost, and availability.

Performance Guidelines

In general, larger sprocket diameters will provide for smoother operation, less vibration, and longer life. We recommend using sprockets with at least 21 teeth whenever possible. Also, to assure proper meshing of sprockets and chain we recommend they be purchased from the same source.

Guide Type

Similar to chains, sprockets can be grouped into two broad categories: center guide and side guide.

Center Guide A groove machined in the center of the sprocket face accepts the chain's center guide link. Two grooves are machined for two center guide.

Side Guide The sprocket fits between the chain's side guide plates.

Sprocket Face Profiles

One Center Guide

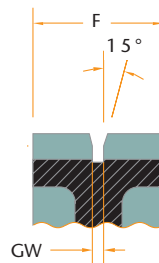

Two Center Guide

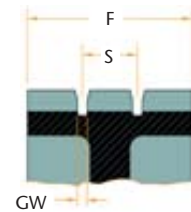

F = Face Width, the same as the nominal chain width

Center Guide Groove Width and Guide Spacing

Pitch	3/16"	3/8"	1/2"	5/8"	3/4"	1"	1-1/2"	2"
GW	1.3	3.2	3.2	4.0	4.0	6.4	6.4	6.4
S*		25.4	25.4	50.8	101.6	101.6	101.6	101.6

Table values in millimeters

*Only applies to sprockets for two center guide chains

Side Guide

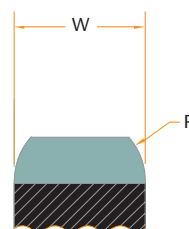

$$W_{\max} = WBG - X$$

WBG = Chain width between guides
(See Chain data tables)

Sprocket Width and Chamfer Data for RP and SC Sprockets

Pitch	3/16"	3/8"	1/2"	5/8"	3/4"	1"	1-1/2"
X	0.5	1.6	1.6	1.6	1.6	3.2	3.2
R	0.8	4.8	6.4	7.9	9.5	12.7	19.1

Table values in millimeters

Consult Ramsey for RPV Sprocket Dimensions

Hub Types

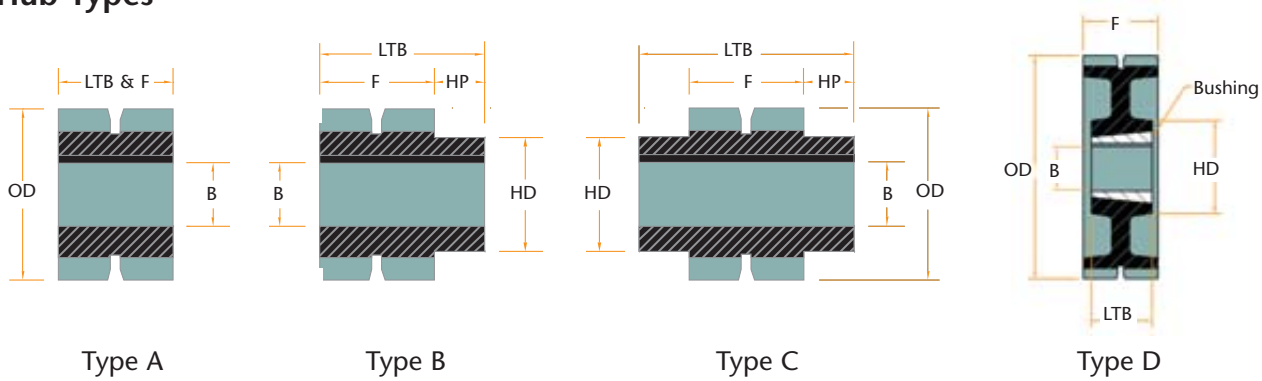

F = Nominal Chain Width **HD** = Hub Diameter
B = Bore **LTB** = Length Through the Bore
OD = Outside Diameter **HP** = Hub Projection

RPV Stock Sprockets

3/8" pitch

19 mm Nominal Face Width-Type B Hub			Actual Face Width = 16.8 mm					
Number of Teeth	Part Number	Pitch Diameter	Outside Diameter	Minimum Plain Bore	Maximum Bore	Hub Diameter	Length Thru Bore	Approximate Weight (kg)
19	RPV303-19	57.9	54.3	12.7	29.4	41.3	35.7	0.4
21	RPV303-21	63.9	60.5	12.7	32.5	47.6	35.7	0.5
23	RPV303-23	70.0	66.6	12.7	34.9	54.0	35.7	0.7
25	RPV303-25	76.0	72.8	19.1	41.3	60.3	35.7	0.8
27	RPV303-27	82.0	79.0	19.1	44.5	66.7	35.7	1.0
29	RPV303-29	88.1	85.2	19.1	46.0	73.0	35.7	1.2
31	RPV303-31	94.2	91.3	19.1	54.0	78.6	35.7	1.4
38	RPV303-38	115.3	112.6	19.1	73.0	100.0	35.7	2.3
42	RPV303-42	127.5	124.8	19.1	84.1	111.9	35.7	2.9
57	RPV303-57	172.9	170.5	31.8	114.3	152.4	35.7	5.3
76	RPV303-76	230.5	228.2	31.8	114.3	152.4	35.7	7.6

25 mm Nominal Face Width-Type B Hub			Actual Face Width = 22.9 mm					
Number of Teeth	Part Number	Pitch Diameter	Outside Diameter	Minimum Plain Bore	Maximum Bore	Hub Diameter	Length Thru Bore	Approximate Weight (kg)
19	RPV304-19	57.9	54.3	12.7	29.4	41.3	41.3	0.5
21	RPV304-21	63.9	60.5	12.7	32.5	47.6	41.3	0.6
23	RPV304-23	70.0	66.6	12.7	34.9	54.0	41.3	0.8
25	RPV304-25	76.0	72.8	19.1	41.3	60.3	41.3	1.0
27	RPV304-27	82.0	79.0	19.1	44.5	66.7	41.3	1.2
29	RPV304-29	88.1	85.2	19.1	46.0	73.0	41.3	1.4
31	RPV304-31	94.2	91.3	19.1	54.0	78.6	41.3	1.6
38	RPV304-38	115.3	112.6	19.1	73.0	100.0	41.3	2.6
42	RPV304-42	127.5	124.8	19.1	84.1	111.9	41.3	3.4
57	RPV304-57	172.9	170.5	31.8	114.3	152.4	41.3	6.2
76	RPV304-76	230.5	228.2	31.8	114.3	152.4	41.3	9.3

Unless indicated, All dimensions in millimeters

RPV Stock Sprockets

3/8" pitch

38 mm Nominal Face Width-Type B Hub				Actual Face Width = 35.6 mm				
Number of Teeth	Part Number	Pitch Diameter	Outside Diameter	Minimum Plain Bore	Maximum Bore	Hub Diameter	Length Thru Bore	Approximate Weight (kg)
19	RPV306-19	57.9	54.3	12.7	29.4	41.3	54.8	0.7
21	RPV306-21	63.9	60.5	12.7	32.5	47.6	54.8	0.9
23	RPV306-23	70.0	66.6	12.7	34.9	54.0	54.8	1.1
25	RPV306-25	76.0	72.8	19.1	41.3	60.3	54.8	1.3
27	RPV306-27	82.0	79.0	19.1	44.5	66.7	54.8	1.5
29	RPV306-29	88.1	85.2	19.1	46.0	73.0	54.8	1.9
31	RPV306-31	94.2	91.3	19.1	54.0	78.6	54.8	2.2
38	RPV306-38	115.3	112.6	19.1	73.0	100.0	54.8	3.5
42	RPV306-42	127.5	124.8	19.1	84.1	111.9	54.8	4.4
57	RPV306-57	172.9	170.5	31.8	114.3	152.4	54.8	8.3
76	RPV306-76	230.5	228.2	31.8	114.3	152.4	54.8	13.1

1/2" pitch

25 mm Nominal Face Width-Type B Hub				Actual Face Width = 22.9 mm				
Number of Teeth	Part Number	Pitch Diameter	Outside Diameter	Minimum Plain Bore	Maximum Bore	Hub Diameter	Length Thru Bore	Approximate Weight (kg)
19	RPV404-19	77.2	72.4	12.7	36.5	56.4	50.8	1.1
21	RPV404-21	85.2	80.6	12.7	42.9	63.5	50.8	1.5
23	RPV404-23	93.3	88.8	19.1	46.0	73.0	50.8	1.8
25	RPV404-25	101.3	97.1	19.1	54.0	81.0	50.8	2.2
27	RPV404-27	109.4	105.4	19.1	60.3	88.9	50.8	2.7
29	RPV404-29	117.5	113.5	19.1	65.1	96.8	50.8	3.2
31	RPV404-31	125.5	121.7	19.1	69.9	105.6	63.5	4.6
38	RPV404-38	153.8	150.2	19.1	95.3	134.1	63.5	7.3
42	RPV404-42	169.9	166.4	19.1	111.1	150.8	63.5	9.2
57	RPV404-57	230.5	227.3	31.8	114.3	152.4	63.5	12.3
76	RPV404-76	307.3	304.2	25.4	63.5	92.1	50.8	14.1

Unless indicated, All dimensions in millimeters

RPV Stock Sprockets

1/2" pitch

38 mm Nominal Face Width-Type B Hub				Actual Face Width = 35.6 mm				
Number of Teeth	Part Number	Pitch Diameter	Outside Diameter	Minimum Plain Bore	Maximum Bore	Hub Diameter	Length Thru Bore	Approximate Weight (kg)
19	RPV406-19	3.038	2.851	0.50	1.44	2.22	2.50	3.3
21	RPV406-21	3.355	3.175	0.50	1.69	2.50	2.50	4.3
23	RPV406-23	3.672	3.498	0.75	1.81	2.88	2.50	5.1
25	RPV406-25	3.989	3.821	0.75	2.13	3.19	2.50	6.3
27	RPV406-27	4.307	4.149	0.75	2.38	3.50	2.50	7.6
29	RPV406-29	4.625	4.47	0.75	2.56	3.81	2.50	9.0
31	RPV406-31	4.942	4.792	0.75	2.75	4.16	3.00	12.3
38	RPV406-38	6.055	5.913	0.75	3.75	5.28	3.00	19.7
42	RPV406-42	6.691	6.553	0.75	4.38	5.94	3.00	24.6
57	RPV406-57	9.076	8.949	1.25	4.50	6.00	3.00	35.4
76	RPV406-76	12.099	11.978	1.00	2.50	3.63	2.50	46.1
51 mm Nominal Face Width-Type B Hub				Actual Face Width = 48.3 mm				
19	RPV408-19	3.038	2.851	0.50	1.44	2.22	3.00	4.1
21	RPV408-21	3.355	3.175	0.50	1.69	2.50	3.00	5.2
23	RPV408-23	3.672	3.498	0.75	1.81	2.88	3.00	6.3
25	RPV408-25	3.989	3.821	0.75	2.13	3.19	3.00	7.7
27	RPV408-27	4.307	4.149	0.75	2.38	3.50	3.00	9.2
29	RPV408-29	4.625	4.47	0.75	2.56	3.81	3.00	10.9
31	RPV408-31	4.942	4.792	0.75	2.75	4.16	3.00	12.7
38	RPV408-38	6.055	5.913	0.75	3.75	5.28	3.00	20.1
42	RPV408-42	6.691	6.553	0.75	4.38	5.94	3.00	25.1
57	RPV408-57	9.076	8.949	1.25	4.50	6.00	3.50	43.6
76	RPV408-76	12.099	11.978	1.00	2.50	3.63	3.00	60.7
76 mm Nominal Face Width-Type B Hub				Actual Face Width = 73.7 mm				
19	RPV412-19	3.038	2.851	0.50	1.44	2.22	4.00	5.3
21	RPV412-21	3.355	3.175	0.50	1.69	2.50	4.00	6.9
23	RPV412-23	3.672	3.498	0.75	1.81	2.88	4.00	8.6
25	RPV412-25	3.989	3.821	0.75	2.13	3.19	4.00	10.5
27	RPV412-27	4.307	4.149	0.75	2.38	3.50	4.00	12.6
29	RPV412-29	4.625	4.47	0.75	2.56	3.81	4.00	14.7
31	RPV412-31	4.942	4.792	0.75	2.75	4.16	4.00	17.3
38	RPV412-38	6.055	5.913	0.75	3.75	5.28	4.00	27.2
42	RPV412-42	6.691	6.553	0.75	4.38	5.94	4.00	33.9
57	RPV412-57	9.076	8.949	1.25	4.50	6.00	4.50	60.2
76	RPV412-76	12.099	11.978	1.00	2.50	3.63	4.00	83.2

Unless indicated, All dimensions in millimeters

RP and SC Stock Sprockets

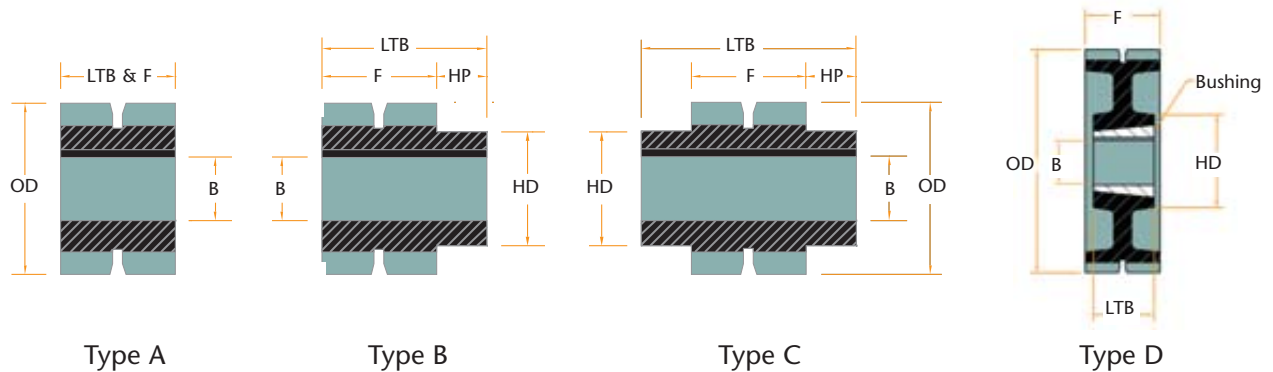

F = Nominal Chain Width
B = Bore
OD = Outside Diameter
HD = Hub Diameter
LTB = Length Through the Bore
HP = Hub Projection

3/8" pitch

25 mm Nominal Face Width

Number of Teeth	Part Number	Pitch Diameter	Outside Diameter	Hub Type	Minimum Plain Bore	Maximum Bore	Hub Diameter	Length Thru Bore	Approx Weight(kg)	Material
17	SC304-17	51.8	50.5	B	12.7	22.2	38.1	44.5	0.4	Steel
19	SC304-19	57.9	56.6	B	12.7	31.8	41.3	44.5	0.6	Steel
21	SC304-21	63.9	62.8	B	12.7	33.3	47.6	44.5	0.7	Steel
23	SC304-23	74.5	69.0	B	12.7	38.1	54.0	44.5	0.9	Steel
25	SC304-25	76.0	75.2	B	12.7	44.5	60.3	44.5	1.1	Steel

1/2" pitch

25 mm Nominal Face Width

Number of Teeth	Part Number	Pitch Diameter	Outside Diameter	Hub Type	Minimum Plain Bore	Maximum Bore	Hub Diameter	Length Thru Bore	Approx Weight(kg)	Material
17	404-17	69.1	67.3	B	19.1	34.9	50.8	38.1	0.7	Steel
19	404-19	77.2	75.5	B	19.1	41.3	58.7	44.5	0.9	Steel
21	404-21	85.2	83.7	B	19.1	47.6	68.3	44.5	1.2	Steel
23	404-23	93.3	92.0	B	19.1	54.0	76.2	44.5	1.6	Steel
25	404-25	101.3	100.2	B	19.1	60.3	84.1	44.5	2.0	Steel
38	404-38	153.8	153.4	C	25.4	63.5	101.6	44.5	3.6	Steel
38	404-38 TLB	153.8	153.4	D	1615 TLB		101.6	38.1	2.7	Steel
57	404-57	230.5	230.6	C	25.4	63.5	101.6	38.1	8.6	Steel
57	404-57 TLB	230.5	230.6	D	1615 TLB		101.6	38.1	7.3	Steel
76	404-76	307.3	307.5	C	25.4	63.5	101.6	38.1	13.4	Steel
76	404-76 TLB	307.3	307.5	D	1615 TLB		101.6	50.8	14.5	Steel
95	404-95	384.1	384.4	C	28.6	76.2	127.0	50.8	23.8	Steel
95	404-95 TLB	384.1	384.4	D	2517 TLB		127.0	44.5	18.1	Steel
114	404-114	460.9	461.3	C	28.6	76.2	127.0	50.8	15.0	Cast Iron
114	404-114 TLB	460.9	461.3	D	2517 TLB		127.0	44.5	12.9	Cast Iron

Unless indicated, All dimensions in millimeters

RP and SC Stock Sprockets

1/2" pitch

51 mm Nominal Face Width

Number of Teeth	Part Number	Pitch Diameter	Outside Diameter	Hub Type	Minimum Plain Bore	Maximum Bore	Hub Diameter	Length Thru Bore	Approx Weight(lb)	Material
17	408-17	69.1	67.3	B	22.2	34.9	50.8	69.9	1.1	Steel
19	408-19	77.2	75.5	B	22.2	41.3	58.7	69.9	1.6	Steel
21	408-21	85.2	83.7	B	22.2	47.6	68.3	69.9	2.0	Steel
23	408-23	93.3	92.0	B	22.2	54.0	76.2	69.9	2.5	Steel
25	408-25	101.3	100.2	B	22.2	60.3	84.1	69.9	3.2	Steel
38	408-38	153.8	153.4	C	25.4	63.5	101.6	69.9	7.3	Steel
38	408-38 TLB	153.8	153.4	D	1615 TLB		120.7	38.1	4.1	Steel
57	408-57	230.5	230.6	C	25.4	63.5	127.0	76.2	17.2	Steel
57	408-57 TLB	230.5	230.6	D	2517 TLB		171.5	44.5	11.3	Steel
76	408-76	307.3	307.5	C	31.8	63.5	127.0	76.2	18.6	Cast Iron
76	408-76 TLB	307.3	307.5	D	2517 TLB		146.1	63.5	16.3	Cast Iron
95	408-95	384.1	384.4	C	31.8	76.2	139.7	76.2	18.8	Cast Iron
95	408-95 TLB	384.1	384.4	D	2525 TLB		146.1	63.5	16.3	Cast Iron
114	408-114	460.9	461.3	C	31.8	76.2	127.0	76.2	21.3	Cast Iron
114	408-114 TLB	460.9	461.3	D	2525 TLB		127.0	63.5	18.1	Cast Iron

76 mm Nominal Face Width

17	412-17	69.1	67.3	B	25.4	34.9	50.8	95.3	1.4	Steel
19	412-19	77.2	75.5	B	25.4	41.3	58.7	95.3	1.8	Steel
21	412-21	85.2	83.7	B	25.4	47.6	68.3	95.3	2.5	Steel
23	412-23	93.3	92.0	B	25.4	54.0	76.2	95.3	3.2	Steel
25	412-25	101.3	100.2	B	25.4	60.3	84.1	95.3	4.1	Steel
38	412-38	153.8	153.4	C	25.4	63.5	101.6	95.3	10.0	Steel
38	412-38 TLB	153.8	153.4	D	2517 TLB		25.4	44.5	4.5	Steel
57	412-57	230.5	230.6	C	31.8	63.5	114.3	101.6	24.0	Steel
57	412-57 TLB	230.5	230.6	D	2525 TLB		114.3	63.5	16.8	Steel
76	412-76	307.3	307.5	C	31.8	63.5	114.3	101.6	16.6	Cast Iron
76	412-76 TLB	307.3	307.5	D	2525 TLB		114.3	63.5	12.5	Cast Iron
95	412-95	384.1	384.4	C	34.9	76.2	152.4	101.6	33.6	Cast Iron
95	412-95 TLB	384.1	384.4	D	2525 TLB		152.4	63.5	21.5	Cast Iron
114	412-114	460.9	461.3	C	34.9	76.2	152.4	101.6	31.1	Cast Iron
114	412-114 TLB	460.9	461.3	D	3030 TLB		152.4	76.2	24.3	Cast Iron

3/4" pitch

76 mm Nominal Face Width

Number of Teeth	Part Number	Pitch Diameter	Outside Diameter	Hub Type	Minimum Plain Bore	Maximum Bore	Hub Diameter	Length Thru Bore	Approx Weight(lb)	Material
17	612-17	103.7	100.9	B	31.8	52.4	76.2	95.3	3.6	Steel
19	612-19	115.7	113.3	B	31.8	60.3	87.3	95.3	5.0	Steel
21	612-21	127.8	125.6	B	31.8	69.9	100.0	95.3	6.4	Steel
23	612-23	139.9	138.0	B	34.9	82.6	112.7	95.3	8.2	Steel
25	612-25	152.0	150.3	B	34.9	92.1	123.8	95.3	10.0	Steel
38	612-38	230.7	230.1	C	34.9	76.2	101.6	101.6	22.7	Steel
38	612-38 TLB	230.7	230.1	D	2525 TLB		152.4	63.5	16.3	Steel
57	612-57	345.8	345.8	C	34.9	88.9	152.4	101.6	26.3	Cast Iron
57	612-57 TLB	345.8	345.8	D	3030 TLB		152.4	76.2	18.6	Cast Iron
76	612-76	461.0	461.3	C	34.9	88.9	152.4	101.6	29.7	Cast Iron
76	612-76 TLB	461.0	461.3	D	3030 TLB		152.4	76.2	23.6	Cast Iron
95	612-95	576.2	576.7	C	38.1	114.3	190.5	101.6	45.4	Cast Iron
95	612-95 TLB	576.2	576.7	D	3535 TLB		190.5	88.9	43.5	Cast Iron
114	612-114	691.4	692.0	C	38.1	114.3	196.9	101.6	59.6	Cast Iron
114	612-114 TLB	691.4	692.0	D	3535 TLB		196.9	88.9	55.1	Cast Iron

Unless indicated, All dimensions in millimeters

Sprocket Diameters

CALCULATING OUTSIDE DIAMETERS

In the tables below, locate the diameter factor that corresponds to the number of teeth in your sprocket and your chain type. Multiply this factor by the sprocket pitch (in millimeters) to obtain the outside diameter in millimeters.

RPV Sprockets-Outside Diameter Factors

Number of Teeth	Diameter Factor		Number of Teeth	Diameter Factor		Number of Teeth	Diameter Factor		Number of Teeth	Diameter Factor	
	Type 139	Type 115		Type 139	Type 115		Type 139	Type 115		Type 139	Type 115
18	5.4	5.7	39	12.1	12.4	60	18.9	19.1	81	25.6	25.8
19	5.7	6.0	40	12.5	12.7	61	19.2	19.4	82	25.9	26.1
20	6.0	6.3	41	12.8	13.0	62	19.5	19.7	83	26.2	26.4
21	6.3	6.6	42	13.1	13.4	63	19.8	20.1	84	26.5	26.8
22	6.7	6.9	43	13.4	13.7	64	20.1	20.4	85	26.8	27.1
23	7.0	7.3	44	13.7	14.0	65	20.5	20.7	86	27.1	27.4
24	7.3	7.6	45	14.1	14.3	66	20.8	21.0	87	27.5	27.7
25	7.6	7.9	46	14.4	14.6	67	21.1	21.3	88	27.8	28.0
26	8.0	8.2	47	14.7	15.0	68	21.4	21.7	89	28.1	28.3
27	8.3	8.6	48	15.0	15.3	69	21.7	22.0	90	28.4	28.7
28	8.6	8.9	49	15.3	15.6	70	22.0	22.3	91	28.7	29.0
29	8.9	9.2	50	15.7	15.9	71	22.4	22.6	92	29.1	29.3
30	9.3	9.5	51	16.0	16.2	72	22.7	22.9	93	29.4	29.6
31	9.6	9.8	52	16.3	16.6	73	23.0	23.2	94	29.7	29.9
32	9.9	10.2	53	16.6	16.9	74	23.3	23.6	95	30.0	30.3
33	10.2	10.5	54	16.9	17.2	75	23.6	23.9	96	30.3	30.6
34	10.5	10.8	55	17.3	17.5	76	24.0	24.2	97	30.6	30.9
35	10.9	11.1	56	17.6	17.8	77	24.3	24.5	98	31.0	31.2
36	11.2	11.4	57	17.9	18.1	78	24.6	24.8	99	31.3	31.5
37	11.5	11.8	58	18.2	18.5	79	24.9	25.2	100	31.6	31.8
38	11.8	12.1	59	18.5	18.8	80	25.2	25.5			

RP and SC Sprockets-Outside Diameter Factors

Number of Teeth	Diameter Factor	Number of Teeth	Diameter Factor	Number of Teeth	Diameter Factor	Number of Teeth	Diameter Factor
18	5.623	39	12.397	60	19.112	81	25.809
19	5.947	40	12.717	61	19.431	82	26.128
20	6.271	41	13.037	62	19.750	83	26.447
21	6.595	42	13.357	63	20.070	84	26.766
22	6.919	43	13.677	64	20.388	85	27.084
23	7.243	44	13.997	65	20.708	86	27.403
24	7.568	45	14.317	66	21.027	87	27.722
25	7.890	46	14.637	67	21.346	88	28.040
26	8.213	47	14.957	68	21.665	89	28.359
27	8.536	48	15.227	69	21.984	90	28.678
28	8.859	49	15.597	70	22.303	91	28.997
29	9.181	50	15.917	71	22.622	92	29.315
30	9.504	51	16.236	72	22.941	93	29.634
31	9.828	52	16.556	73	23.259	94	29.953
32	10.150	53	16.876	74	23.578	95	30.271
33	10.471	54	17.196	75	23.897	96	30.590
34	10.793	55	17.515	76	24.216	97	30.909
35	11.115	56	17.834	77	24.535	98	31.228
36	11.437	57	18.154	78	24.853	99	31.546
37	11.757	58	18.473	79	25.172	100	31.865
38	12.149	59	18.793	80	25.491		

Unless otherwise indicated, All dimensions are in millimeters

Ordering Information

CHAIN ORDERING INFORMATION

If you know the chain's part number ...

Simply supply the part number along with the chain length in pitches, feet or meters.

If you have a chain description, but do not know the part number...

Please specify the following details.

- o Product type: For example, RPV, RP, SC or competitors product type
- o Pitch: Best determined by measuring across 3 pin heads and dividing the measurement by 2.
- o Chain width across the links and across the heads
- o Guide type
- o Chain length in pitches, feet or meters

If you have an engineering drawing...

Simply fax, email, or mail the drawing to Ramsey.

If you are uncertain about what you need...

Contact Ramsey. Our experienced sales engineers will be pleased to assist you in identifying a chain for your application.

SPROCKET ORDERING INFORMATION

If you know your sprocket part number...

Simply supply the part number along with the following details:

- o Hub type A, B, C or D
- o Hub projection
- o Bore diameter
- o Keyway size
- o Hub diameter

If you know your chain part number...

A compatible sprocket can be identified by the chain part number followed by the number of sprocket teeth. For example a 21 tooth sprocket for a RamPower 1/2" pitch by 25 mm wide chain can be specified as RP404-21. Also please supply the following machining details:

- o Hub type A, B, C or D
- o Hub projection
- o Bore diameter
- o Keyway size
- o Hub diameter

If you have an engineering drawing...

Simply fax, email, or mail the drawing to Ramsey. After a review of the drawing we will respond to your inquiry and supply a quotation if desired.

If you are uncertain about what you need...

Contact Ramsey. Our experienced sales engineers will be pleased to assist you in identifying sprockets for your application.

DESIGN SUGGESTIONS

Sprockets. For long life, sprockets should have a minimum of 21 teeth. For smoother, quieter drives use a larger number of teeth.

Drive Ratios. Ratios of 12:1 or greater are possible, but above 8:1 it is usually desirable to make the reduction in two steps.

Shaft Center Adjustment. Center adjustment to allow for wear is always desirable. It is particularly important in vertical center drives. Typically the amount of adjustment should equal at least 1% of the center distance.

Shaft Center Distance. The center distance should be great enough that the chain wraps the small sprocket at least 120 degrees. Center distances should generally not exceed 60 pitches.

Chain Length. Whenever possible, chain length should be an even number of pitches so an offset section can be avoided.

Tensioning Devices. An idler sprocket or shoe can often be used to maintain tension on fixed center drives.

Chain Width. The use of a wider than recommended chain will result in a more rugged drive and improved drive life.

Drive Enclosures. Fully enclosed drives with proper lubrication are desirable for maximum service life and personnel safety.

Non-horizontal And Vertical Shafts. Drives using non-horizontal shafts often work best with side guide chain and an automatic tensioner. Consult Ramsey for specific recommendations.

DRIVE POSITIONS

The preferred position for a drive is where a line between shaft centers is horizontal or inclined not more than 45 degrees. Under ordinary conditions the slack strand may be either on the upper or lower side of the drive.

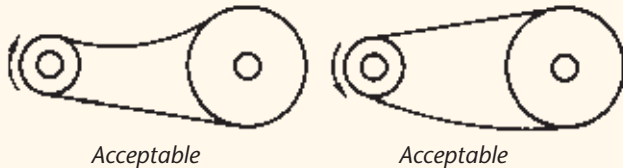

Where the center distance is comparatively short, slack on the lower strand is preferable. With the slack on the upper strand there is a tendency for the chain to be forced out of proper engagement with the sprockets.

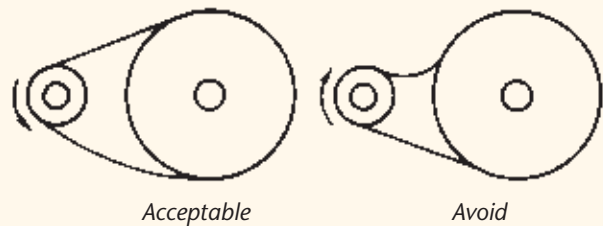

Vertical drives should be avoided if possible. They must be run fairly taut which means frequent adjustment of centers as the chain elongates due to normal wear. Less care and adjustment will be required if the drive can be positioned slightly off the vertical.

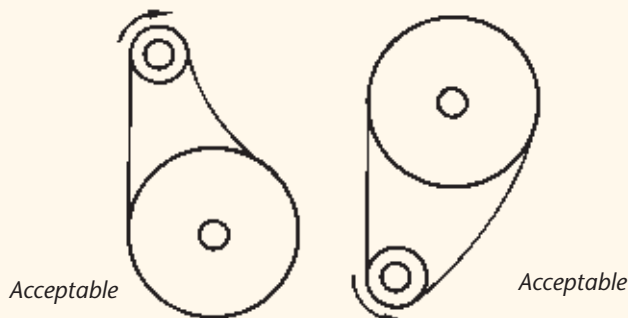

Drives with long center distances and small sprockets should have the slack strand on the bottom. With the slack on top there is danger of the upper strand hitting the lower as the chain elongates.

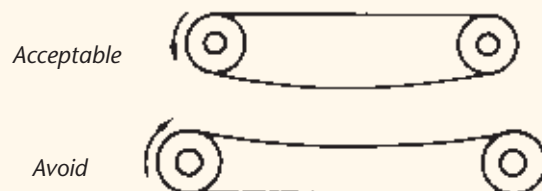

DRIVE SELECTION-STEP BY STEP

Drive selection consists of choosing the appropriate chain and sprockets for the space, loads, and speeds involved. Often more than one pitch and width will work in a given situation. In such cases one may choose two or three possible selections and base the final choice on factors such as cost, stock availability, ruggedness or space availability. Contact Ramsey for a computer program that simplifies the drive selection process.

Information Needed

- Type of power source and application
- Power to be transmitted(W)
- RPM of shafts(N1=faster shaft speed, N2=slower shaft speed)
- Shaft center distance(CD)
- Shaft diameters and keyway sizes

Follow These Steps

1. Choose a service factor(SF) from the table on page 30
2. Compute the design power(W_d) by multiplying the power to be transmitted(W) by the service factor.
3. Use the speed of the faster moving shaft(N1) to make a tentative pitch selection(p) from the chart below.

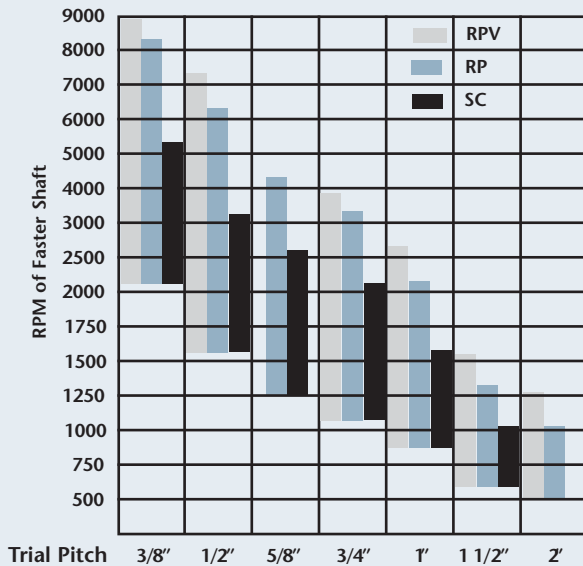

4. Select the number of teeth in the small sprocket(Z1), making sure the sprocket can accommodate the shaft diameter. See maximum sprocket bores in sprocket tables.

5. Use the following equations to calculate the required chain width(C_w). If the required chain width is not readily available it may be necessary to go to a wider chain or a larger sprocket.

For RPV and RP
$$C_w = \frac{98(W_d)}{p \cdot V \cdot R (1 - V^2(5.19 \times 10^{-4}))}$$

For SC
$$C_w = \frac{419(W_d)}{p \cdot V (2.16 - V/(Z-8))}$$

where:

C_w = required width (mm)

R = factor from table

V = chain speed (M/s)

W_d = design power (kw)

p = pitch (mm)

Table of R Values

	Pitch						
	3/8"	1/2"	5/8"	3/4"	1"	1 1/2"	2"
RPV(SG)	1.5	1.8	na	1.6	1.5	1.1	1.0
RPV(CG)	1.5	1.8	na	1.3	1.2	1.1	1.0
RP	.922	1.0	1.0	1.0	1.0	1.0	1.0

6. Select the large sprocket (Z2) by multiplying the number of teeth in the small sprocket by the desired shaft speed ratio.
 $Z_2 = Z_1 \times N_1/N_2$

7. Compute the chain length using the table provided on page 25. If the computed length is fractional, round off to the nearest whole number of pitches. An even number of pitches is always preferable to an odd number of pitches which requires an offset section. If an offset section is required it will be necessary to increase the width of the chain by 25% to account for the offsets reduced tensile strength. Note: offset sections are not available for RPV chain.

8. Compute the new center distance (C_d) for the rounded off chain length. The following formula provides an approximate center distance. When fixed center drives are used or extremely accurate cen-

$$C_d = \frac{C_L - \frac{(Z_1 + Z_2)}{2} + \text{SQRT} \left(C_L - \frac{Z_1 + Z_2}{2} \right)^2 - 8 \left(\frac{Z_2 - Z_1}{4\pi^2} \right)^2}{4}$$

Where:

C_d = corrected center distance in pitches

C_L = chain length in pitches

Z1 = number of teeth in smaller, faster moving sprocket

Z2 = number of teeth in larger, slower moving sprocket

ter distance is required consult Ramsey.

9. Select a method for lubricating the drive.

Forced feed lubrication will provide optimum results and is recommended whenever chain speeds exceed 12.7 m/s. Drip or bath type lubrication may be acceptable at lower speeds. Additional information on lubrication is given in the section describing lubrication. Also, if the drive will not operate inside a housing, a chain enclosure is recommended.

Drive Selection Example

DRIVE SELECTION EXAMPLE

Fan(propeller type),
 Power source: electric motor
 Power: 26 kw
 Shaft RPM: 1750 RPM (N1), 800 RPM (N2)
 Center distance: 700 mm, adjustable centers
 Shaft diameter = 38 mm

1. Determine the service factor(SF), using chart on page 30
 Service factor = 1.3

2. Calculate the design power(W_d)
 $W_d = W \times SF = 26 \text{ kw} \times 1.3 = 33.8 \text{ kw}$

3. Choose an initial pitch (p)
 Entering the pitch selection chart (page 24) at 1750 rpm, select 1/2" pitch RP series chain.

4. Select the number of teeth in the small sprocket(Z1).
 A minimum of 21 teeth is recommended. From the sprocket table on page 19, the maximum bore for a 21 tooth sprocket is 47.6mm. This is greater than the shaft diameter so the sprocket choice is acceptable.

5. Calculate minimum chain width(C_w)

$$W_d = 33.8 \text{ kw}$$

R = 1.0, from table on page 24

$$V = pZN = (12.7 \times 21 \times 1750)/60,000 = 7.78 \text{ m/s}$$

$$C_w = \frac{(98 \times 33.8)}{(12.7 \times 1.0 \times 7.78) \times (1 - [(7.78)^2 \times (5.19 \times 10^{-4})])}$$

$$C_w = 34.8 \text{ mm}$$

The nearest larger standard chain width ,from page 9, is 38 mm wide, RP406.

6. Calculate the number of teeth in the larger sprocket(Z2)
 $Z2 = Z1 \times (N1/N2) = 21 \times 2.19 = 46 \text{ teeth}$

7. Calculate the chain length(C_L)
 $C = 55.1, A = 67, S = 25$
 From table below T = 15.83, and $C_L = 143.7$
 Round to even number of pitches, $C_L = 144 \text{ pitches}$

8. Calculate the new center distance(C_d)
 From page 24, $C_d = 54.962 \text{ pitches}$
 Converting to mm, $C_d = 54.962 \times 12.7 = 698 \text{ mm}$

CHAIN LENGTH CALCULATION

Information Needed:

CD = center distance (mm)
 Z2 = number of teeth in large sprocket
 Z1 = number of teeth in small sprocket
 p = chain pitch (mm)

Procedure

1. Calculate C, where $C = CD/p$
2. Calculate A, where $A = Z1+Z2$
3. Calculate S, where $S = Z2-Z1$
4. Refer to the below and find the T value corresponding to the calculated S value.
5. Chain length in pitches, $C_L = 2C + (A/2) + (T/C)$

Note: If chain length is fractional round off to the nearest whole number of pitches. An even number of pitches is always preferable to an odd number which requires an offset section.

An offset section (also called a hunting link section) must be used when a chain contains an odd number of links. If an offset section is required, it will be necessary to increase the width of the chain by 25% to account for the reduced tensile strength of the offset.

S	T	S	T	S	T
1	0.03	35	31.03	69	120.60
2	0.10	36	32.83	70	124.12
3	0.23	37	34.68	71	127.69
4	0.41	38	36.58	72	131.31
5	0.63	39	38.53	73	134.99
6	0.91	40	40.53	74	138.71
7	1.24	41	42.58	75	142.48
8	1.62	42	44.68	76	146.31
9	2.05	43	46.84	77	150.18
10	2.53	44	49.04	78	154.11
11	3.06	45	51.29	79	158.09
12	3.65	46	53.60	80	162.11
13	4.28	47	55.95	81	166.19
14	4.96	48	58.36	82	170.32
15	5.70	49	60.82	83	174.50
16	6.48	50	63.33	84	178.73
17	7.32	51	65.88	85	183.01
18	8.21	52	68.49	86	187.34
19	9.14	53	71.15	87	191.73
20	10.13	54	73.86	88	196.16
21	11.17	55	76.62	89	200.64
22	12.26	56	79.44	90	205.18
23	13.40	57	82.30	91	209.76
24	14.59	58	85.21	92	214.40
25	15.83	59	88.17	93	219.08
26	17.12	60	91.19	94	223.82
27	18.47	61	94.25	95	228.61
28	19.86	62	97.37	96	233.44
29	21.30	63	100.54	97	238.33
30	22.80	64	103.75	98	243.27
31	24.34	65	107.02	99	248.26
32	25.94	66	110.34	100	253.30
33	27.58	67	113.71		
34	29.28	68	117.13		

Lubrication

CHOOSE THE PROPER LUBRICANT

Proper drive lubrication is essential for a long service life. In sufficient quantities a lubricant penetrates chain joints to protect against corrosion, dissipate heat, cushion impact, and flush away debris. The chain width equations on page 24 presume that adequate lubrication is used.

For most applications a good grade of non-detergent petroleum based oil is recommended. Multiviscosity oils are not recommended. Generally greases and high viscosity oils are too thick to penetrate chain joints and should be avoided.

A chain which does not receive sufficient lubrication will wear prematurely. An early indication is the appearance of a reddish brown, iron oxide deposit on the chain. When this is found the method and/or quantity of lubricant should be improved.

Chain drives should also be covered or enclosed in a manner that will protect the oil from contamination by dirt or moisture. For best results oil should be filtered and cooled when necessary.

Ambient Temperature (°F)	Recommended Lubricant
< 40	SAE 5*
40-90	SAE 10*
> 90	SAE 20
* Type A or B Automatic Transmission Fluid may be substituted	

LUBRICATION METHODS

Type I - Manual And Drip Lubrication

Oil is applied periodically to the inside of the chain with a brush, drip tube, or oil can. With a drip feed system, one oil drop opening should be provided for each 19 mm of chain width. The volume and frequency of lubrication should be enough to prevent chain overheating or discoloration.

This method may be suitable for applications involving low speeds and loads, or short duty cycles. It is not generally recommended for chain speeds exceeding 1,000 ft/min.

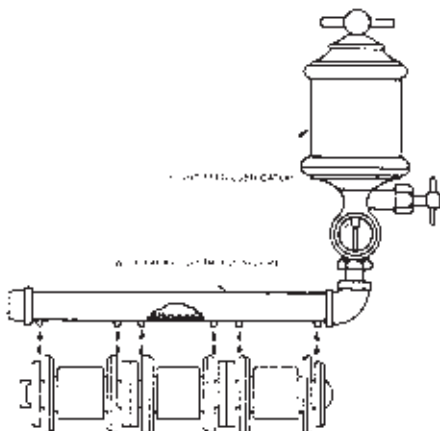

Warning: Do not attempt to manually lubricate or service any chain drive while it is operating. Serious injury could result.

Lubrication

Type II - Bath and Disc Lubrication

Bath-The lower strand of chain runs through an oil bath. The oil level should be such that the pitch line of the chain is just submerged. Also, to prevent excessive heat generation, only a short section of chain should run through the bath.

Disc-A rotating disc picks up oil from a reservoir and directs it to the chain by means of a baffle or trough. The chain is not submerged in oil. This method requires that the disc rim speed be between 4 m/s and 40 m/s.

These methods may be suitable for chain speeds up to approximately 12 m/s

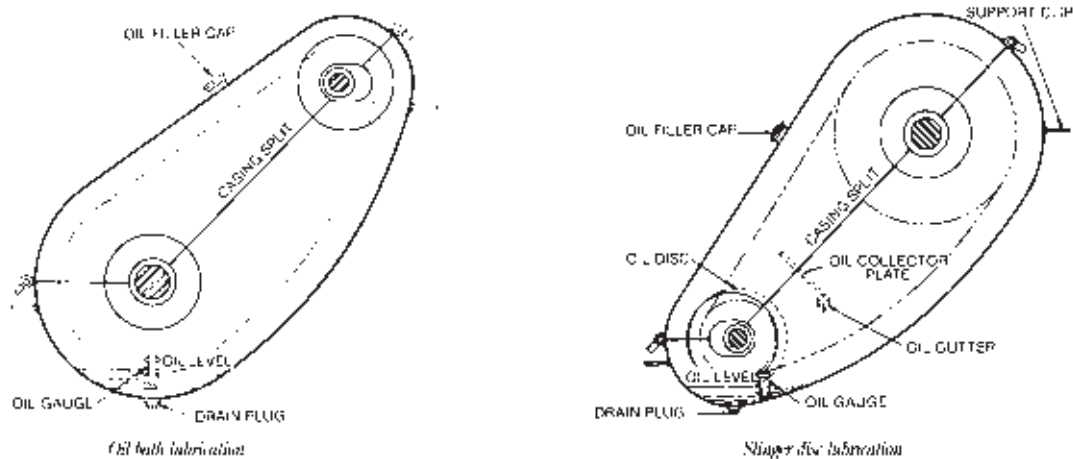

Type III - Force Feed Lubrication

Lubricant is supplied in a continuous stream by a circulating pump and distribution pipe. The oil should be directed to the inside of the slack strand with one oil stream for each 25 mm of chain width. This is the preferred method of lubrication, particularly for drives with heavy loads or speeds greater than 12.7 m/s. Recommended oil flow rates will vary depending on the application. The equation below lists minimum recommended flow rates based on the power transmitted. In general, oil flow rates should be 3.8 liters per minute, for every 25 mm of chain width.

Minimum Flow Rates

$$F = \frac{Pw + 0.4}{39.4}$$

Where:

F = Flow rate in liters per minute

Pw = Power transmitted in kilowatts

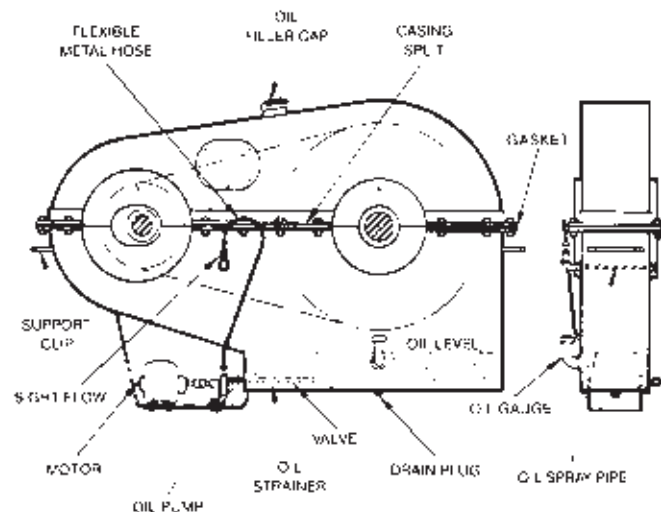

Installation Guidelines

DRIVE INSTALLATION

Shaft Parallelism

Shaft parallelism should be checked before installing sprockets. Typically shafts should be parallel to within 0.4 mm per meter. Ramsey should be consulted for applications where shafts are not horizontal.

Sprocket Alignment

Sprockets should be aligned on the shafts so there is little or no lateral offset between sprocket faces. Excessive wear will result if the sprockets are not properly aligned.

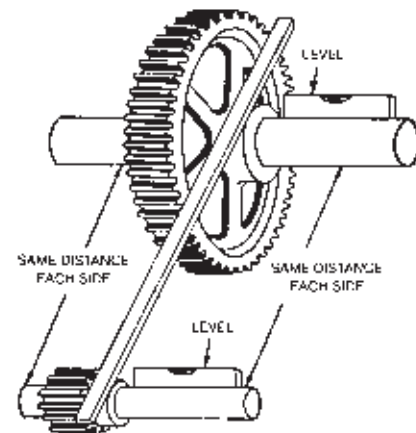

Chain Connection

A variety of connector styles are used in Ramsey chain, depending on the chain type and customer preference. See page 29 for illustrations of the most common styles.

During connection, It is very important that the ends of the chain be properly laced together and that the pins be inserted with their convex surfaces facing one another.



Chain clamped to the sprocket to simplify connection.

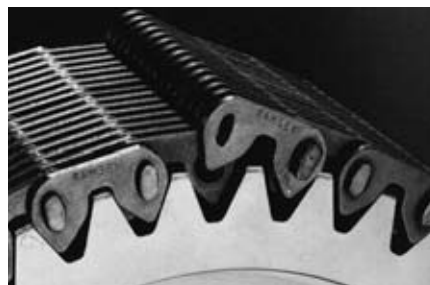

Symmetric chain lacing during connection

Tensioning

Chains must be properly tensioned at installation and checked periodically. Chain life will be shortened both by running too tight and running too loose. A chain which is too tight has an additional load imposed on it which will accelerate wear and increase noise. A chain which is loose enough to whip or surge can be subjected to shock loads and excessive wear.

On drives where the line between shaft centers is horizontal or inclined as much as 60 degrees from horizontal, the chain should be tensioned to allow a sag in one strand equal to approximately two percent of the shaft center distance. The chain should be taut in vertical or fixed center drives, and on drives subject to shock loads, reversing, or dynamic braking.

Chain Connection

CONNECTION

Once the links in each end are properly laced together, chain connection is completed by first inserting the longer pin and then the shorter pin. Position the pins so that the convex surfaces contact one another. Complete the connection by putting a washer or side link on the long pin where appropriate and then fasten with a spirol pin or cotter. Optional annealed connecting pins are available that are secured by peening over the pin end. The illustrations show the most common connection methods; other methods are available upon request.

For RPV and RP chains 3/8" - 1/2" pitch



Bring the ends of the chain together so the holes are aligned



Insert longer pin through the chain.



Insert short pin so convex pin surfaces are in contact



Install spirol roll pin

For RPV and RP chains 5/8" - 2" pitch



Bring the ends of the chain together so the holes are aligned



Insert longer pin through the chain.



Insert short pin so convex pin surfaces are in contact



Put washer on pin and install cotter or spirol roll pin

For SC Chains 3/8" - 1" pitch



Bring the ends of the chain together so the holes are aligned

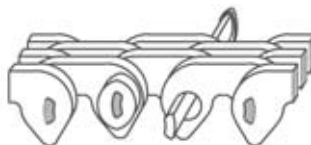

Insert longer pin through the chain.

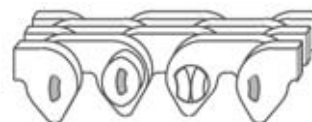

Insert short pin so convex pin surfaces are in contact



Put washer on long pin and install cotter.

Other chain connections are available

Service Factors

Service factors are used during drive selection to compensate for less than optimum drive conditions. The chain width formulas on page 24 are based on the following drive conditions:

* Power source = electric motor, hydraulic motor, turbine, or engine with fluid coupling

* Proper lubrication

For conditions that differ from those listed above, the power to be transmitted must be multiplied by a service factor to obtain the design power. The design power is then used to calculate the required chain width.

Select an appropriate service factor from the service factor table, then add one or more of the additional factors listed here:

Fixed center distance =0.2

Engine with mechanical coupling =0.2

Inadequate lubrication =0.2 to 0.5

Service Factor Table

AGITATORS (paddle or propeller)									
Pure liquid	1.1								
Liquids (variable density)	1.2								
BAKERY MACHINERY									
Dough Mixer	1.2								
BLOWERS		See Fans							
BREWING & DISTILLING EQUIPMENT									
Bottling Machinery	1.0								
Brew Kettles, cookers, mash tubs	1.0								
Scale Hopper (Frequent starts)	1.2								
BRICK & CLAY EQUIPMENT									
Auger machines, cutting table	1.3								
Brick machines, dry press, granulator	1.4								
Mixer, pug mill, rolls	1.4								
CEMENT PLANTS									
Kilns	1.4								
CENTRIFUGES	1.4								
COMPRESSORS									
Centrifugal, rotary (lobe)	1.1								
Reciprocating (1 or 2 cyl.)	1.6								
Reciprocating (3 or more cyl.)	1.3								
CONSTRUCTION EQUIPMENT OR OFF-HIGHWAY VEHICLES									
Drive line , power take-off		Consult Ramsey							
Accessory drives									
CONVEYORS									
Apron, bucket, pan, elevator	1.4								
Belt (ore, coal, sand, salt)	1.2								
Belt (light packages, oven)	1.0								
Screw, flight (heavy duty)	1.6								
CRANES & HOISTS									
Main hoist (medium duty)	1.2								
Main hoist (heavy duty), skip hoist	1.4								
CRUSHING MACHINERY									
Ball mills, crushing rolls, jaw crushers	1.6								
DREDGES									
Conveyors, cable reels	1.4								
Jigs, screens	1.6								
Cutter head drives		Consult Ramsey							
Dredge pumps	1.6								
FANS & BLOWERS									
Centrifugal, propeller, vane	1.3								
Positive blowers (lobe)	1.5								
GRAIN MILL MACHINERY									
Sifters, purifiers, separators	1.1								
Grinders, hammer mills	1.2								
Roller mills	1.3								
GENERATORS & EXCITERS	1.2								
ICE MACHINES	1.5								
LAUNDRY MACHINERY									
Dampeners, Washers	1.1								
Tumblers	1.2								
MACHINE TOOLS									
Grinders, lathes, drill press	1.0								
Boring mills, milling machines	1.1								
MARINE DRIVES		Consult Ramsey							
MILLS									
Rotary type:									
Ball, Pebble, Rod, Tube, Roller	1.5								
Dryers, Kilns, tumbling barrels	1.6								
Metal type:									
Draw bench carriage, main drive	1.5								
FORMING MACHINES		Consult Ramsey							
MIXERS									
Concrete	1.6								
Liquid, Semi-liquid	1.1								
OIL INDUSTRY MACHINERY									
Compounding Units	1.1								
Pipe line pumps	1.4								
Slush pumps	1.5								
Draw works	1.8								
Chillers, Paraffin filter presses, Kilns	1.5								
PAPER INDUSTRY MACHINERY									
Agitators, bleachers	1.1								
Barker(mechanical)	1.6								
Beater, Yankee Dryer	1.3								
Calendars, Dryer, Paper Machines	1.2								
Chippers,winder drums	1.5								
PRINTING MACHINERY									
Embossing, flat bed presses, folders	1.2								
Paper cutter, rotary press, linotype	1.1								
Magazine, Newspaper Presses	1.5								
PUMPS									
Centrifugal, gear, lobe, vane	1.2								
Dredge	1.6								
Pipe line	1.4								
Reciprocating (3 or more cyl.)	1.3								
Reciprocating (1 or 2 cyl.)	1.6								
RUBBER & PLASTICS EQUIPMENT									
Calendars, rolls, tubers									
Tire-building, Banbury Mills	1.5								
Mixers, sheeters	1.6								
Extruders	1.5								
SCREENS									
Conical, revolving	1.2								
Rotary, gravel, stone, vibrating	1.5								
STOKERS	1.1								
DYNAMOMETERS		Consult Ramsey							
TEXTILE INDUSTRY									
Spinning frames, twistors, Wrappers	1.0								
Batchers, calendars, looms	1.1								



Уважаемые партнёры!

Компания **КПД** готова предложить комплектующие к оборудованию самого высокого качества.

Основные наши позиции это:

- **Редукторы и мотор-редукторы David Brown / Benzlers** Швеция – это недоступный ранее на украинском рынке уровень качества, надёжности, уровня технических инноваций и технического совершенства. Представлены редукторы всех компоновок.

- **Электродвигатели** асинхронные Brook Crompton, **электромоторы с тормозом** MGM, Италия.

- **Цепи роликовые** приводные и **грузовые** (конвейерные) производства Ketten Wulf, Германия, Sedis, Франция, вильчатые скребковые цепи Sircatene, Италия.

- **Звёздочки для цепей** Sati, Италия

- **Плоские транспортёрные цепи и модульные ленты** Regina

- **Ремни приводные** клиновые, поликлиновые (ручейковые),

вариаторные, круглые, зубчатые специальные, производства компаний **Vando, Япония, Brecoflex, Германия.**

- **Шкивы, монтажные втулки и муфты** со склада, производства компании **Desch, Германия.**

- **Зубчатые цепи** Ramsey, США

- **Гидромуфты** и дисковые тормоза Transfluid, Италия.

- **Карданные валы** Elso/Elbe, Германия, широкий диапазон конструкций и размеров, крестовины карданных валов.

- **СТS обгонные муфты** из Италии. Высокое качество изготовления.

Наши специалисты всегда готовы помочь решить проблемы эксплуатации оборудования и предложить надёжные комплектующие.

С уважением,

Павинов Михаил

инженер

ООО «Компания промышленных деталей»

(098) 083-58-09

misha@motor-reduktor.com.ua

www.motor-reduktor.com.ua



Drive Maintenance

Inspection

Periodic drive inspection and adjustment will often result in increased service life and lower costs. An inspection should include sprocket alignment, tension, lubrication, and the general condition of chain and sprockets.

Tensioning and Elongation

As a chain wears, its pitch will elongate and the chain will wrap an increasingly larger pitch circle. Re-tensioning of the chain will normally eliminate problems associated with excess chain slack. Also, with Ramsey chains this elongation occurs uniformly throughout the length of the chain so efficient, smooth operation is maintained.

However, when elongation becomes excessive the chain can skip teeth and damage the sprocket. It is best to replace the chain before this happens. The size of the large sprocket will limit the allowable elongation of the chain. In general, a chain will not properly wrap sprockets when it has elongated by $200/N\%$ where N = the number of teeth in the larger sprocket. Other application related considerations may further limit the amount of acceptable elongation.

Alignment

Sprocket alignment must be maintained for optimum drive performance and chain life. Examine the sides of the chain guide links for excessive wear or gouging; these are often symptoms of misaligned sprockets.

Periodically check that sprockets are securely fastened. If sprocket position has changed since installation go through the alignment procedure used during installation.

ENGINEERING FORMULAS

p = pitch in millimeters			
Z = number of teeth in sprocket			
V = chain speed in meters per second	$W = \frac{TN}{9549}$	$L = \frac{19,098W}{pZN}$	$T = \frac{LP_d}{2}$
W = power in kilowatts			
N = revolutions per minute	$W = VL$	$L = \frac{W}{V}$	$T = \frac{9549W}{N}$
P_d = pitch diameter in millimeters			
L = working load in kilo Newtons	$L = \frac{60,000W}{pZN}$	$V = \frac{pZN}{60,000}$	$P_d = \frac{p}{\sin(180/Z)}$
T = torque in Newton meters			

Catalog# 601-504



Ramsey Products
CORPORATION

Ramsey Products Corporation
P.O. Box 668827
3701 Performance Road (28214)
Charlotte, N.C. 28266-8827
Tel: (704) 394-0322
Fax: (704) 394-9134
www.ramseychain.com
E-mail: sales@ramseychain.com

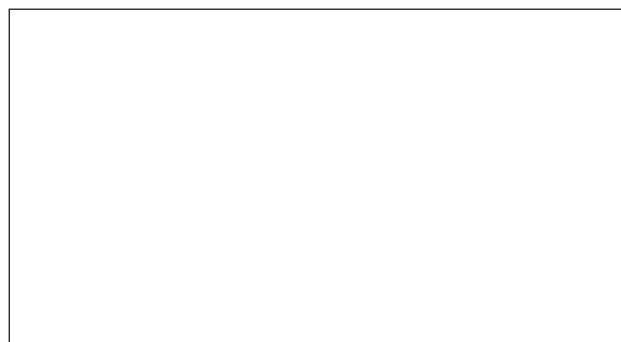

AUTHORIZED DISTRIBUTOR



Ramsey Products
EUROPE

Ramsey Products Europe
Ninaberlaan 83
7447 AC Hellendoorn (or)
The Netherlands
Tel: +31 (0) 548 659032
Fax: +31 (0) 548 659010
E-mail: ramsey@eurodev.nl