

# high speed



**TEXTRON** POWER TRANSMISSION



## Setting the standard at high speed

When it comes to specifying high speed gearboxes for critical applications such as pumps, compressors and generators, there's only one standard that matters – the best.

Textron Power Transmission (TPT) sets that standard for the energy and petrochemical industries, building on its wide experience and enviable reputation to deliver the reliability and enhanced performance demanded by users worldwide.

## A global capability

Advanced high speed gearboxes operating at 50,000rpm and beyond are supplied to both OEMs and end users within the most competitive timescales through pre-engineering of adaptable units to speed delivery.

TPT has the facilities and the know-how to create the high speed unit that precisely matches your specification. Matching performance to application, TPT will also build in special integral lubrication and cooling systems to ensure long and trouble-free service, and can extend the same vital features to the pump or driving motor to reduce space requirements and minimise pipe runs.

World-class manufacturing is backed by comprehensive in-house test facilities and a global service and repair capability that ensures your reputation is safe in our hands.

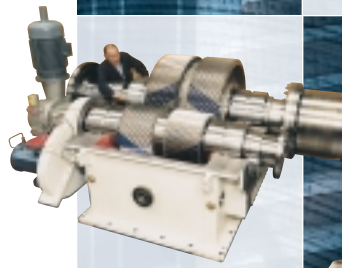
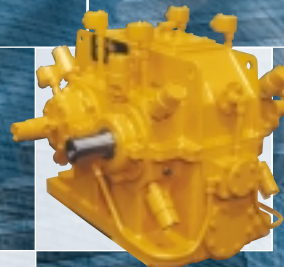
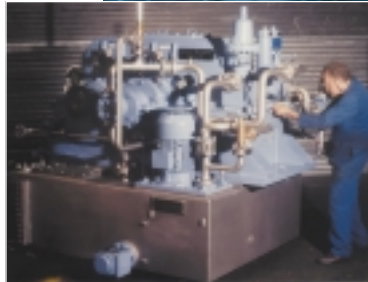
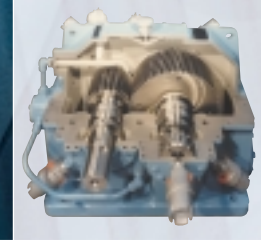

# HIGH SPEED PRODUCTS IN THE RANGE

0109

Serving an entire spectrum of mechanical drive applications from food, energy, mining and metal; to automotive, aerospace and marine propulsion, Textron Power Transmission is here to make a positive difference to the supply of drive solutions.



**Series A**  
Worm Gear units and geared motors in single & double reduction types



**Series B**  
Conax helicoidal gear geometry right angle gearmotors and reducers



**Series C**  
Right angle drive helical worm geared motors & reducers



**Series D**  
Dual gears on parallel output shafts

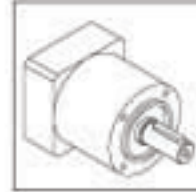

**Series E**  
Economical planetary servo gearboxes

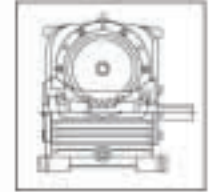

**Extruder Drive**  
Rugged duty reducer takes high screw pressure



**Series F**  
Parallel angle helical bevel helical geared motors & reducers

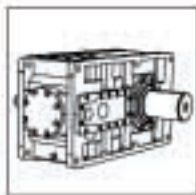

**Series G**  
Helical parallel shaft & bevel helical right angle drive gear units

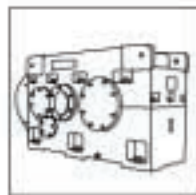

**Series H**  
Large helical parallel shaft & bevel helical right angle drive units

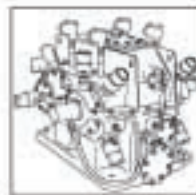

**Highspeed**  
Helical parallel shaft high speed units



**HTP**  
High torque planetary gear units



**Series J**  
Shaft mounted helical speed reducers



**Series K**  
Right angle helical bevel helical geared motors & reducers



**Series M**  
In-line helical geared motors & reducers



**Mill Drives**  
Bevel planetary vertical mill drives

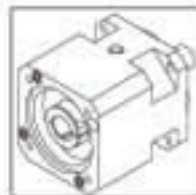

**Series P**  
Precision planetary servo gearboxes

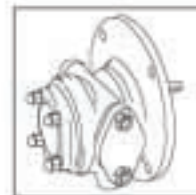

**Pumps**  
Double helical gear pumps



**Series Q**  
In-line planetary geared motors & reducers



**Model RG**  
Right angle gearhead in two precision levels

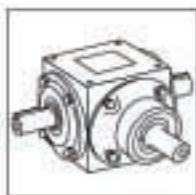

**Series R**  
Right angle spiral bevel gear unit



**Series S**  
Screwjack worm gear unit

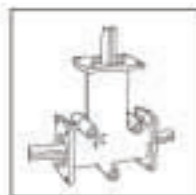

**Series T**  
Right angle straight bevel gear unit

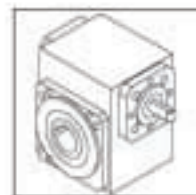

**Series W**  
Precision right angle servo gearboxes



**Winches & Capstans**  
Custom engineered solutions



**Series X Cone Ring**  
Pin and bush elastomer coupling

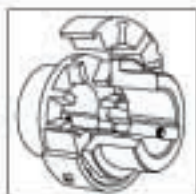

**Series X Flexiwrap**  
Double flexing elastomer coupling



**Series X Gear**  
Torsionally rigid, high torque coupling

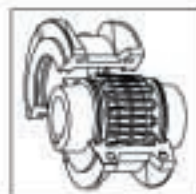

**Series X Grid**  
Double flexing steel grid coupling

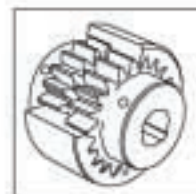

**Series X Nylicon**  
Gear coupling with nylon sleeve



**Series X Torque Limiter**  
Overload protection device

Textron Power Transmission can create custom engineered transmission solutions of any size and configuration.

# HIGH SPEED

## GENERAL DESCRIPTION

0109

### HIGH SPEED GEAR UNITS

High Speed Gearboxes are often used in the most exacting of applications, where expensive down time makes gearbox failure unacceptable. Textron Power Transmission has over 60 years experience in the supply of High Speed Gearboxes, these operating in some of the most arduous working environments in the world.

In these markets we understand our customers' need for a willing partner, flexible in response to their requirements for widely varying designs. Textron Power Transmission provides engineered solutions, project by project, every gearbox designed to meet our customers' specific requirements. Our strength lies in our ability to engineer every conceivable option from a standard range, including;

- Gear and lubrication systems to the highest specifications, including API, AGMA and ISO.
- Lubrication systems to supply the gearbox plus the driving and driven machines.
- Lubrication systems designed as an integral part of the gearbox casing.
- Parallel shaft or planetary designs.
- Single and double helical, to the customers' preference.
- Full instrumentation packages (RTDs, vibration probes etc.)
- Barring drives designed to match the machine's inertia.

Textron Power Transmission has supplied many units operating at powers up to 54Mw or 72,414 HP and speeds up to 40,000 rpm. Our extensive reference list (available on request) details our experience in applications including;

- Generator sets (offshore and land based)
- Compressors (offshore and land based).
- Fire Pumps (offshore).
- Water Injection Pumps (offshore).
- Lift Pumps (offshore).
- Boiler Feed Pumps (power stations).
- Descaling Pumps (steelworks).

Textron Power Transmission. Flexible in design to meet our customers' specific needs-without compromise.

As improvements in design are being made continually this specification is not to be regarded as binding in detail and drawings and capacities are subject to alteration without notice. Certified drawings will be sent on request.

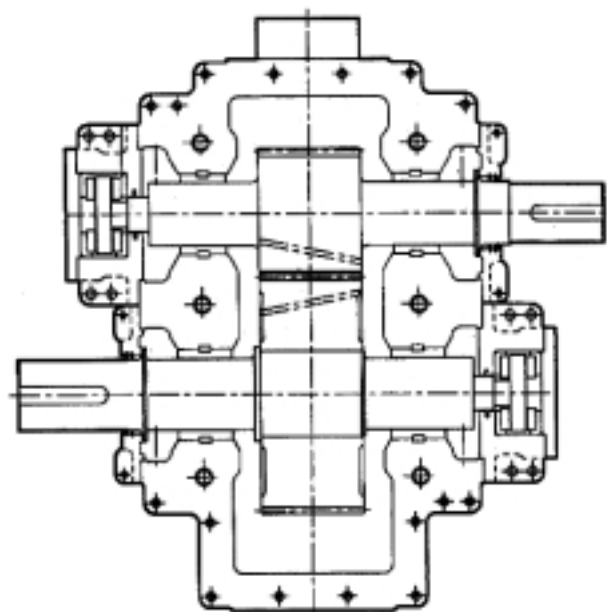
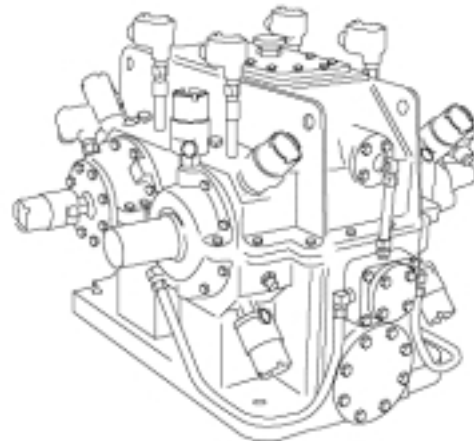

Typical Single Helical Gear Unit

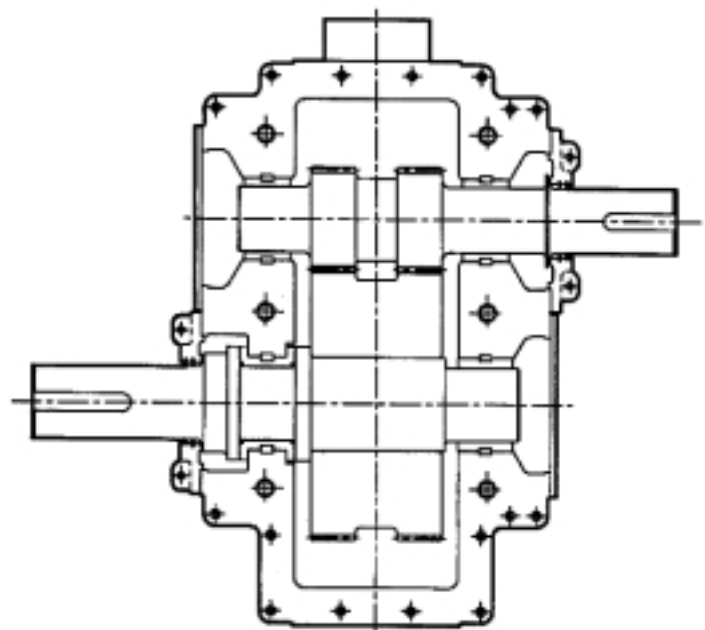

Typical Double Helical Gear Unit

# HIGH SPEED DESIGN AND MANUFACTURING SPECIFICATIONS FOR A.P.I 613 GEAR UNITS

0109

## Ratings

The units will conform to A.P.,613 specification.

## Gears

Either single helical or double helical gearing can be supplied.

Both pinion and wheel are made from high grade alloy steel, carburised, hardened and profile ground. Where necessary, the tooth profiles and helix are modified to compensate for deflection and anticipated thermal deformation under load.

The design of the gear teeth and the high gear accuracies achieved during the profile grinding operations ensure quiet running.

The gear teeth are produced with protuberance cutters to leave the roots unground for maximum bending strength. Pinions are forged integrally with their shafts, and wheels are shrunk onto their shafts before profile grinding the teeth to ensure a high standard of gear accuracy.

The integrity of the gear tooth material is checked after profile grinding and material tests are undertaken to comply with API.613 requirements.

## Journal Bearings

The shafts are carried in white metal lined thick wall steel bearings, split in halves and mounted directly into the gear case. The bearings are pressure fed hydrodynamic type, and profiles are varied to suit the loading conditions. The special profiled bores ensure stability of the shafts (whirl free) under full and no load running conditions resulting in minimum vibration levels.

The steel and white metal materials are ultrasonically checked to ensure material quality and integrity of the white metal to steel bond.

## Thrust Bearings

For single helical gears, each shaft is fitted with a double tilting pad thrust bearing to take the gear axial loads and specified external loads from connected machinery. The bearings are fitted in bolted on housings to provide good access and for ease of maintenance.

For double helical gears, the wheelshaft only is fitted with a double acting tilting pad thrust bearing.

## Gear case

Cast iron gear cases of rugged design ensure accurate gear alignment and good noise/vibration damping. The cases are split on the horizontal centreline of the shafts with metal to metal joints.

Oil drains are provided at either end or on the underside of the gear case to suit customers' requirements and are sized to fully comply with the A.P.I., specification. A generous inspection cover is fitted to the top half to allow full inspection of the gears and the oil spray, thus avoiding the need to lift the top half casing.

The casing is designed to allow for easy mounting of shaft vibration probes and temperature monitoring equipment.

If required, the gear case can be manufactured from nodular cast iron or fabricated steel.

## Lubrication System

The gear units are dry sump type, gears and bearings being pressure lubricated from an external source.

The internal pipework, the spray and external pipework leading from the single oil supply manifold are made from stainless steel.

The gear units are supplied with oil inlet and outlet flange connections which can be made to suit various standards. The gear teeth are sprayed for lubrication and heat dissipation purposes.

Each individual journal and thrust bearing is lubricated from a pressure feed.

The gear units are designed to operate at maximum overall efficiency and therefore minimum lube oil quantity.

If required, Textron Power Transmission will supply the lubrical system.

## Sealing

Both the high and low speed shafts incorporate a non-contact oil flinger and labyrinth arrangement.

## Condition Monitoring

Provision is made adjacent to each journal bearing for the fitting of two non-contact vibration probes at 90 degrees to each other and one at each shaft to monitor axial vibration.

Provision is made for fitting local reading thermometers or distant reading temperature probes (R.T.D.s, thermocouples, etc) at each journal bearing and distant reading temperature probes at thrust bearings. Special features can be included as optional extras.

## Auxiliary Drives

Barring drives and shaft driven lube oil pumps and tachometers can be incorporated or Textron Power Transmission will provide accommodation only for customer's 'Free Issue' equipment if required.

## Quality Control

The Quality Systems and procedures applied during the design manufacture and testing of the gear units are to B.S.5750:Pt 1 (ISO.9001) requirements. These systems are assured, approved and monitored by Lloyd's Register Quality Assurance Limited, ensuring the most rigorous controls maintained.

## Inspection

Inspection points are integrated into the manufacturing cycles from material receipt, through the component manufacturing processes, to final assembly and testing. The latest gear measuring equipment is available to measure pitch, profile and leads gears.

The material heat treatment operations, such as carburising and hardening, are carried out by Textron Power Transmission and are subject to stringent control in order to ensure strict conformance with the specified requirements.

## Testing

The rotating elements of all gear units are dynamically balanced ensure that the residual unbalance is lower than that given in the design calculations.

All gear units are no-load tested at full operating speed. During the test, bearing temperatures, oil flow and oil temperature are monitored, checked and recorded.

Following test running, examination of tooth contact marking is carried out.

Load testing can be undertaken. Up to 59000 kW can be accommodated using a back-to-back test arrangement.

The test facilities are supported by a team of noise and vibration engineers, equipped with a comprehensive range of noise and vibration monitoring instrumentation.

# HIGH SPEED

## TYPICAL SINGLE HELICAL GEAR UNIT SECTIONAL ARRANGEMENT DRAWING AND PARTS LIST

0109

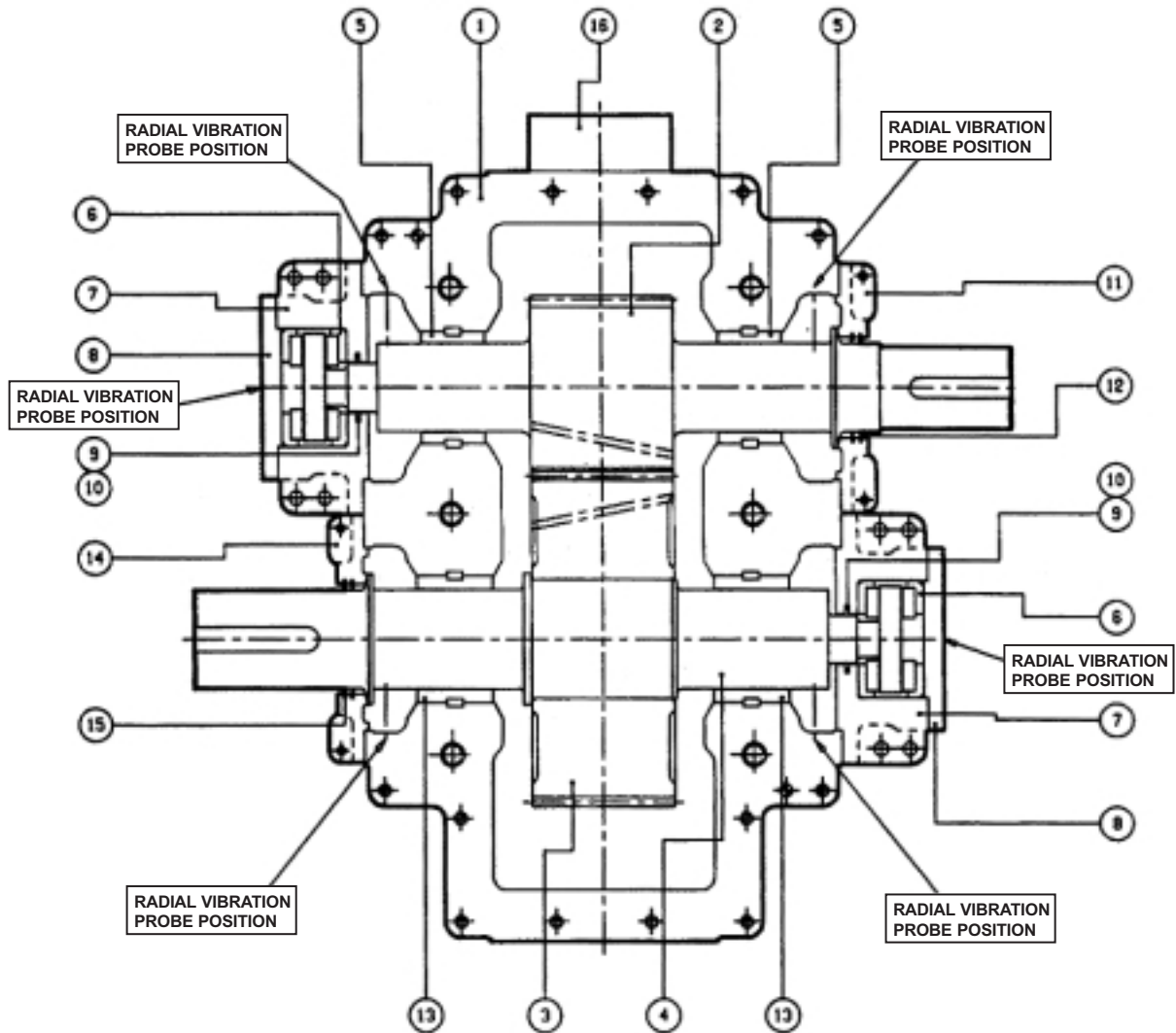

PARTS LIST		
ITEM No	DESCRIPTION	QTY. PER SET
1	GEARCASE	1
2	PINONSHAFT	1
3	WHEEL	1
4	WHEELSHAFT	1
5	PINONSHAFT JOURNAL BEARING	2
6	DOUBLE THRUST BEARING	2
7	THRUST HOUSING	2
8	END COVER	2
9	OIL SEAL	2
10	SEAL GARTER SPRING	2
11	PINONSHAFT OIL CATCHER	1
12	OIL BAFFLE	2
13	WHEEL SHAFT JOURNAL BEARING	2
14	WHEEL SHAFT OIL CATCHER	1
15	OIL BAFFLE	2
16	OIL SUPPLY MANIFOLD	1

# HIGH SPEED SINGLE HELICAL GEAR WITH TILTING PAD TRUST BEARINGS - PRINCIPAL DIMENSIONS (MM)

0109

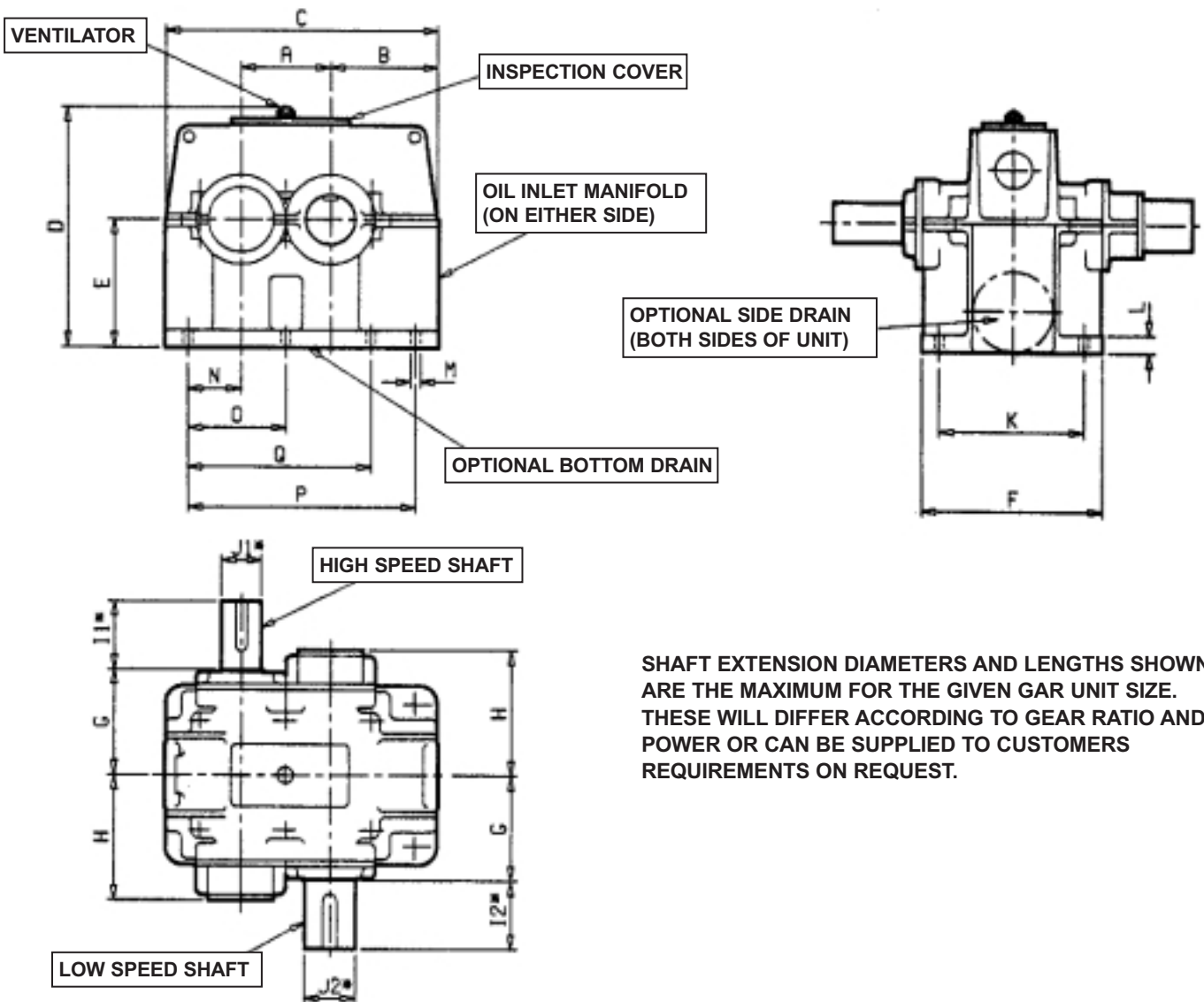

SHAFT EXTENSION DIAMETERS AND LENGTHS SHOWN ARE THE MAXIMUM FOR THE GIVEN GEAR UNIT SIZE. THESE WILL DIFFER ACCORDING TO GEAR RATIO AND POWER OR CAN BE SUPPLIED TO CUSTOMERS REQUIREMENTS ON REQUEST.

UNIT SIZE	A	B	C	D	E	F	G	H	I1" MAX	J1" MAX	I2" MAX	J2" MAX	K	L	Ma	N	O	P	Q	No OF BOLTS	BOLT SIZE
HSW 200	200	250	640	575	300	440	260	325	165	125	165	125	380	40	22	125	-	510	-	4	M20
HSW 250	250	300	775	685	355	500	300	368	200	140	200	140	425	50	26	155	-	635	-	4	M24
HSN 250	250	315	770	700	355	425	235	298	130	90	165	100	355	50	26	150	-	660	-	4	M24
HSW 280	280	335	850	765	400	560	320	415	240	160	240	160	450	55	28	170	310	710	-	6	M24
HSN 280	280	345	815	775	400	475	265	328	165	100	165	110	375	55	26	140	280	710	-	6	M24
HSW 315	315	375	955	850	450	630	350	455	240	180	240	180	500	60	33	190	345	800	-	6	M30
HSN 315	315	375	910	860	450	530	290	380	165	110	165	125	425	60	33	155	315	800	-	6	M30
HSW 355	355	400	1045	925	500	710	415	533	280	200	280	200	560	60	33	220	395	900	-	6	M30
HSN 355	355	425	1015	950	500	600	320	395	165	125	200	140	475	60	33	180	355	900	-	6	M30
HSW 400	400	450	1180	1035	580	800	450	573	280	220	280	220	630	70	39	240	440	1000	-	6	M36
HSN 400	400	475	1130	1050	560	670	345	425	200	140	240	160	530	70	39	190	400	1000	-	6	M36
HSW 450	450	500	1305	1155	630	850	490	593	330	250	330	250	670	70	39	265	485	1120	-	6	M36
HSN 450	450	530	1245	1135	630	710	370	460	240	160	240	180	560	70	39	205	425	1120	-	6	M36
HSW 500	500	550	1410	1280	710	950	560	700	330	260	330	250	750	70	39	280	530	1250	-	6	M36
HSN 500	500	605	1410	1340	710	800	425	500	240	160	240	180	600	70	39	225	475	1250	-	6	M36
HSW 560	560	595	1560	1415	800	1060	610	770	380	280	380	280	850	75	45	325	600	1400	-	6	M42
HSN 560	560	670	1560	1490	800	850	460	545	240	180	280	200	650	75	45	250	530	1400	-	6	M42
HSW 630	630	685	1780	1600	900	1180	680	830	380	320	380	320	950	80	45	375	640	1600	1300	8	M42
HSN 630	630	795	1780	1710	900	950	520	620	280	200	280	220	750	80	45	265	580	1600	1200	8	M42
HSW 710	710	755	1980	1770	1000	1320	710	880	450	340	450	340	1060	80	45	425	710	1800	1450	8	M42
HSN 710	710	880	1980	1895	1000	1060	570	700	280	220	330	250	850	80	45	300	600	1800	1300	8	M42

SEE PAGE 6 FOR HANDLING & ROTATION, SHIPPING SPECIFICATION

# HIGH SPEED HANDING & ROTATION SHIPPING SPECIFICATION

0109

## Handing and Rotation

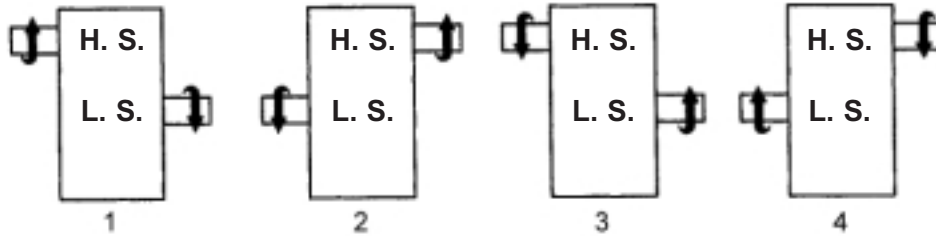

H. S. = HIGH SPEED  
L. S. = LOW SPEED

## Shipping Specification - Kg (approx)

Unit Size	Type HSW Net	Gross	Type HSN Net	Gross
200	510	560	-	-
250	720	790	540	590
280	980	1080	800	880
315	1330	1470	1090	1200
355	1770	1950	1570	1730
400	2390	2630	2180	2400
450	3240	3560	3000	3300
500	4020	4430	3680	4050
560	5050	5550	4840	5320
630	6550	7200	6270	6900
710	8500	9350	8050	8860

# HIGH SPEED

## A.P.I. STANDARD 613 SELECTION PROCEDURE

0109

### A.P.I. Standard 613 Gearbox Selection

1. Determine the service factor from table 1.
2. Calculate the required power capacity per pinion rpm  

$$= \frac{\text{transmitted power (kW)} \times \text{service factor}}{\text{rpm of pinion}}$$
3. Calculate the gearbox ratio  

$$= \frac{\text{rpm of pinion}}{\text{rpm of wheel}}$$
4. Select gearbox size from Table 2

Table 1				MINIMUM SERVICE FACTOR TABLE		
Application	Prime Mover					
	Motor	Turbine	Internal Combustion Engine			
<b>BLOWERS</b>						
Centrifugal	1.4	1.6	1.7			
<b>COMPRESSORS</b>						
Centrifugal	1.4	1.6	1.7			
Axial	1.4	1.6	1.7			
Rotary Lobe (radial, axial, screw, etc )	1.7	1.7	2.0			
Reciprocating	2.0	2.0	2.3			
<b>FANS</b>						
Centrifugal	1.4	1.6	1.7			
Forced Draft	1.4	1.6	1.7			
Induced Draft	1.7	2.0	2.2			
<b>GENERATORS AND EXCITERS</b>						
Base Load or Continuous	1.1	1.1	1.3			
Peak Duty Cycle	1.3	1.3	1.7			
<b>PUMPS</b>						
Centrifugal (Alt service except as listed below)	1.3	1.5	1.7			
Centrifugal - Boiler feed	1.7	2.0	-			
Centrifugal - Hot oil	1.7	2.0	-			
High-speed Centrifugal (Over 3600 rpm)	1.7	2.0	-			
Centrifugal - Water supply	1.5	1.7	2.0			
Rotary - Axial Flow - All types	1.5	1.5	1.8			
Rotary -Gear	1.5	1.5	1.8			
Reciprocating	2.0	2.0	2.3			

See Overleaf for table 2

# HIGH SPEED A.P.I. STANDARD 613 SELECTION PROCEDURE

0109

## A.P.I. STANDARD 613 SELECTION PROCEDURE

Table 2  
HIGH SPEED GEAR UNITS  
RATING TO A.P.I. STANDARD 613

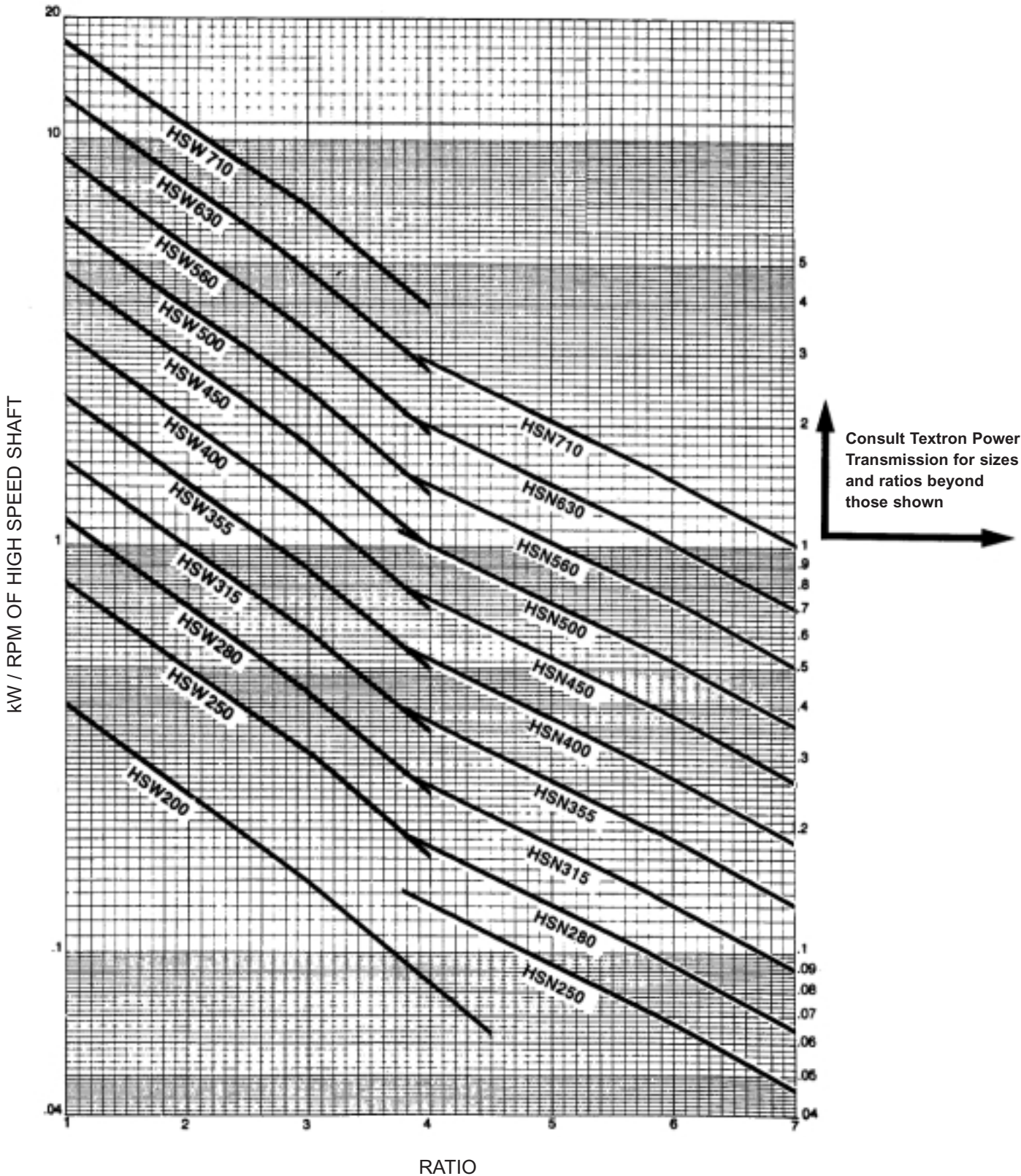

# HIGH SPEED

## A.G.M.A. STANDARD 421-06 SELECTION PROCEDURE

0109

### A.G.M.A. Standard 421-06 Gearbox Selection

1. Determine the service factor from table 1.
2. Calculate the required power capacity per pinion rpm  

$$= \frac{\text{transmitted power (kW)} \times \text{service factor}}{\text{rpm of pinion}}$$
3. Calculate the gearbox ratio  

$$= \frac{\text{rpm of pinion}}{\text{rpm of wheel}}$$
4. Select gearbox size from Table 2

Application	Prime Mover		
	Motor	Turbine	Internal Combustion Engine
<b>BLOWERS</b>			
Centrifugal	1.4	1.6	1.7
<b>COMPRESSORS</b>			
Centrifugal	1.4	1.6	1.7
Axial	1.4	1.6	1.7
Rotary Lobe (radial, axial, screw, etc )	1.7	1.7	2.0
Reciprocating	2.0	2.0	2.3
<b>FANS</b>			
Centrifugal	1.4	1.6	1.7
Forced Draft	1.4	1.6	1.7
Induced Draft	1.7	2.0	2.2
<b>GENERATORS AND EXCITERS</b>			
Base Load or Continuous	1.1	1.1	1.3
Peak Duty Cycle	1.3	1.3	1.7
<b>PUMPS</b>			
Centrifugal (Alt service except as listed below)	1.3	1.5	1.7
Centrifugal - Boiler feed	1.7	2.0	-
Centrifugal - Hot oil	1.7	2.0	-
High-speed Centrifugal (Over 3600 rpm)	1.7	2.0	-
Centrifugal - Water supply	1.5	1.7	2.0
Rotary - Axial Flow - All types	1.5	1.5	1.8
Rotary -Gear	1.5	1.5	1.8
Reciprocating	2.0	2.0	2.3

See Overleaf for table 2

# HIGH SPEED A.G.M.A. STANDARD 421-06 SELECTION PROCEDURE

0109

A.G.M.A. STANDARD 421-06  
SELECTION PROCEDURE

Table 2  
HIGH SPEED GEAR UNITS  
RATING TO A.G.M.A. STANDARD 421-06

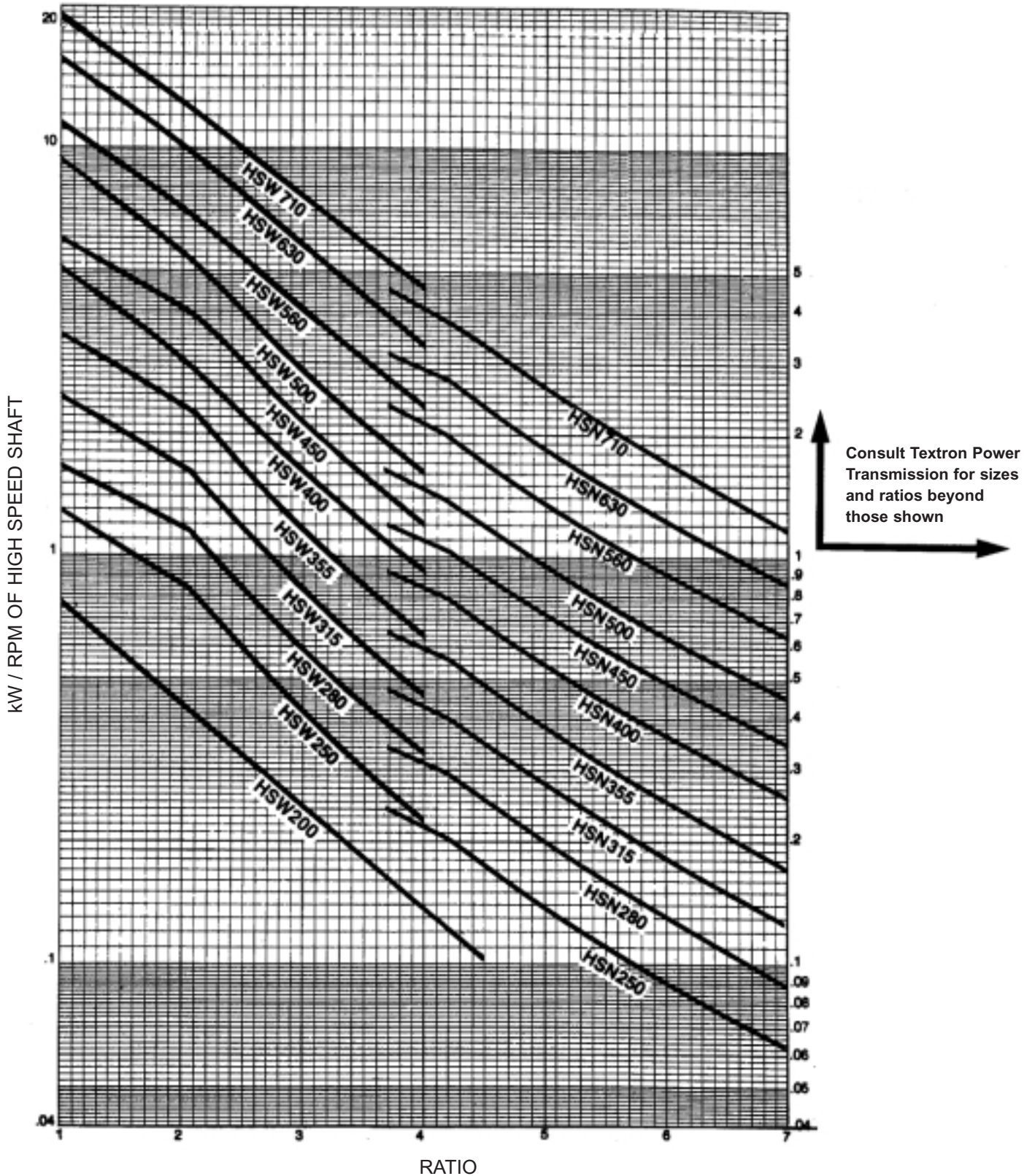

## **General Purpose High Speed Gear Units**

# HIGH SPEED

## DESIGN AND MANUFACTURING SPECIFICATIONS FOR GENERAL PURPOSE GEAR UNITS

0109

### Ratings

The units will conform to any of the recognised international standards such as A.G.M.A., ISO, DIN and British Standards.

### Gears

Double helical gearing is supplied as standard but if required single helical gears can be incorporated.

Both pinion and wheel are made from high grade alloy steel, carburised, hardened and profile ground. Where necessary, the tooth profiles and helix are modified to compensate for deflection and anticipated thermal deformation under load.

The design of the gear teeth and the high gear accuracies achieved during the profile grinding operations ensure quiet running.

The gear teeth are produced with protuberance cutters to leave the roots unground for maximum bending strength. Pinions are forged integrally with their shafts, and wheels are shrunk onto their shafts before profile grinding the teeth to ensure a high standard of gear accuracy.

### Journal Bearings

The shafts are carried in white metal lined thick wall steel bearings, split in halves and mounted directly into the gear case. The bearings are pressure fed hydrodynamic type, and profiles are varied to suit the loading conditions. The special profiled bores ensure stability of the shafts (whirl free) under full and no load running conditions resulting in minimum vibration levels.

The steel and white metal materials are ultrasonically checked to ensure material quality and integrity of the white metal to steel bond.

### Thrust Bearings

For double helical gears, a double acting taper land thrust bearing is incorporated on the low speed shaft line. The thrust bearing is supplied as an integral part of one of the journal bearings.

If single helical gears are supplied, taper land thrust bearings are incorporated. Tilting pad thrust bearings can be incorporated if required.

### Gear case

Cast iron gear cases of rugged design ensure accurate gear alignment and good noise/vibration damping. The cases are split on the horizontal centreline of the shafts with metal to metal joints.

Oil drains are provided at either end or on the underside of the gear case to suit customers' requirements. A generous inspection cover is fitted to the top half to allow full inspection of the gears and the oil spray, thus avoiding the need to lift the top half casing.

The casing is designed to allow for easy mounting of monitoring equipment.

If required, the gear case can be manufactured from nodular cast iron or fabricated steel.

### Lubrication System

The gear units are dry sump type, gears and bearings being pressure lubricated from an external source.

The internal pipework, the spray and external pipework leading from the single oil supply manifold are made from stainless steel.

The gear units are supplied with oil inlet and outlet flange connections which can be made to suit various standards. The gear teeth are sprayed for lubrication and heat dissipation purposes.

Each individual journal and thrust bearing is lubricated from a pressure feed.

The gear units are designed to operate at maximum overall efficiency and therefore minimum lube oil quantity.

If required, Textron Power Transmission will supply the lubrication system.

### Sealing

Both the high and low speed shafts incorporate a non-contacting oil flinger and labyrinth arrangement.

### Condition Monitoring

Provision can be made for fitting local reading thermometers or distant reading temperature probes (R.T.D.s, thermocouples, etc) at each journal bearing and distant reading temperature probes at thrust bearings. Special features can be included as optional extras.

### Auxiliary Drives

Barring drives and shaft driven lube oil pumps and tachometers can be incorporated or Textron Power Transmission will provide accommodation only for customer's 'Free Issue' equipment if required.

### Quality Control

The Quality Systems and procedures applied during the design manufacture and testing of the gear units are to B.S.5750:Pt 1 (ISO.9001) requirements. These systems are assured, approved and monitored by Lloyd's Register Quality Assurance Limited, ensuring the most rigorous controls maintained.

### Inspection

Inspection points are integrated into the manufacturing cycles, from material receipt, through the component manufacturing processes, to final assembly and testing. The latest gear measuring equipment is available to measure pitch, profile and leads of all gears.

The material heat treatment operations, such as carburising and hardening, are carried out by Textron Power Transmission and are subject to stringent control in order to ensure strict conformance with the specified requirements.

### Testing

The rotating elements of all gear units are dynamically balanced ensure that the residual unbalance is lower than that given in the design calculations.

All gear units are no-load tested at full operating speed. During the test, bearing temperatures, oil flow and oil temperature are monitored, checked and recorded.

Following test running, examination of tooth contact marking is carried out.

Load testing can be undertaken. Up to 59000 kW can be accommodated using a back-to-back test arrangement.

The test facilities are supported by a team of noise and vibration engineers, equipped with a comprehensive range of noise and vibration monitoring instrumentation.

# HIGH SPEED

## TYPICAL SINGLE HELICAL GEAR UNIT SECTIONAL ARRANGEMENT DRAWING AND PARTS LIST

0109

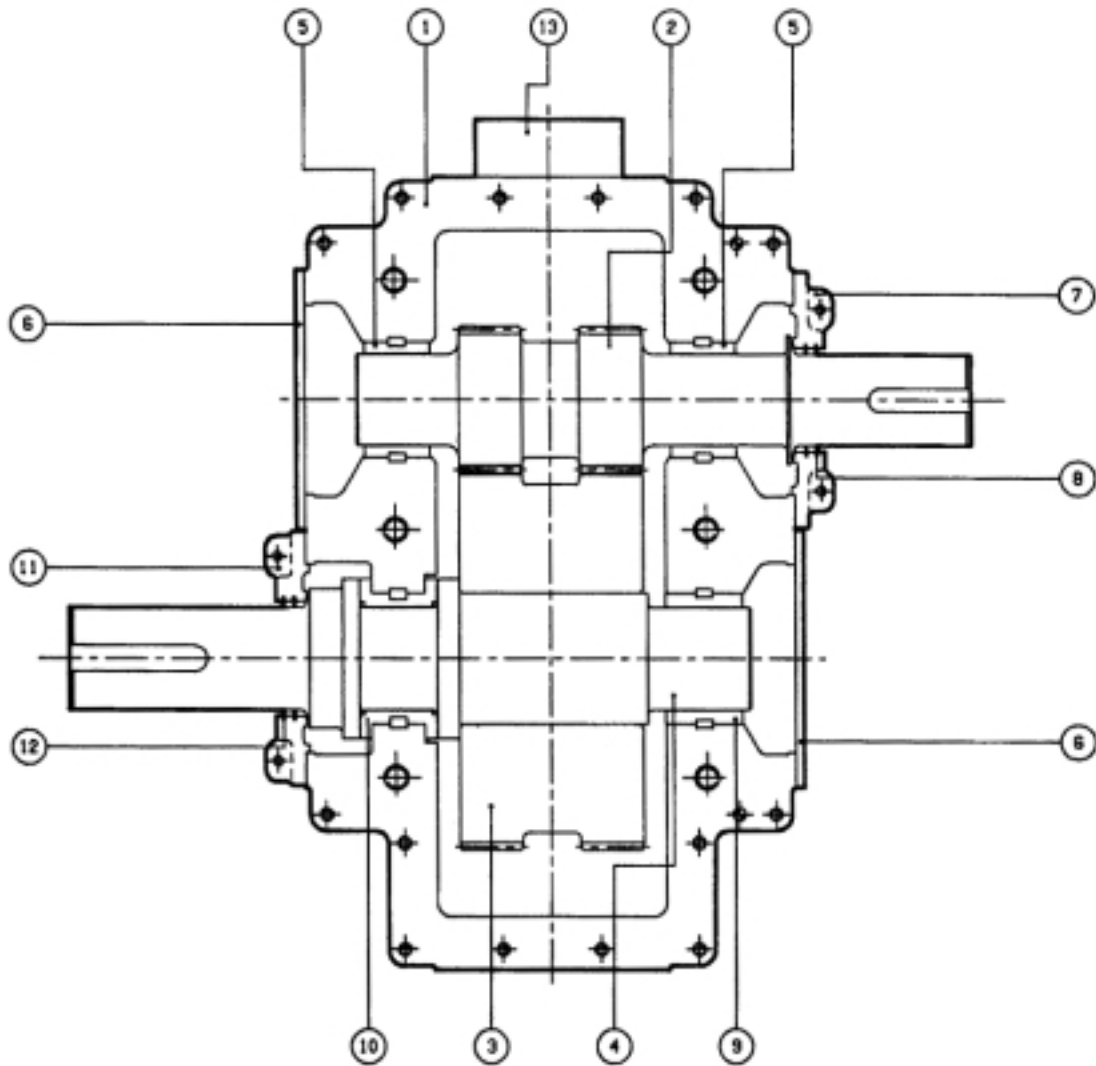

PARTS LIST		
ITEM No	DESCRIPTION	QTY. PER SET
1	GEARCASE	1
2	PINONSHAFT	1
3	WHEEL	1
4	WHEELSHAFT	1
5	PINONSHAFT JOURNAL BEARING	2
6	END COVER	2
7	PINONSHAFT OIL CATCHER	1
8	OIL BAFFLE	2
9	WHEEL SHAFT JOURNAL BEARING	1
10	WHEEL SHAFT TAPER LAND THRUST BEARING	1
11	WHEEL SHAFT OIL CATCHER	1
12	OIL BAFFLE	2
13	OIL SUPPLY MANIFOLD	1

# HIGH SPEED DOUBLE HELICAL GEAR UNIT - PRINCIPAL DIMENSIONS (MM)

0109

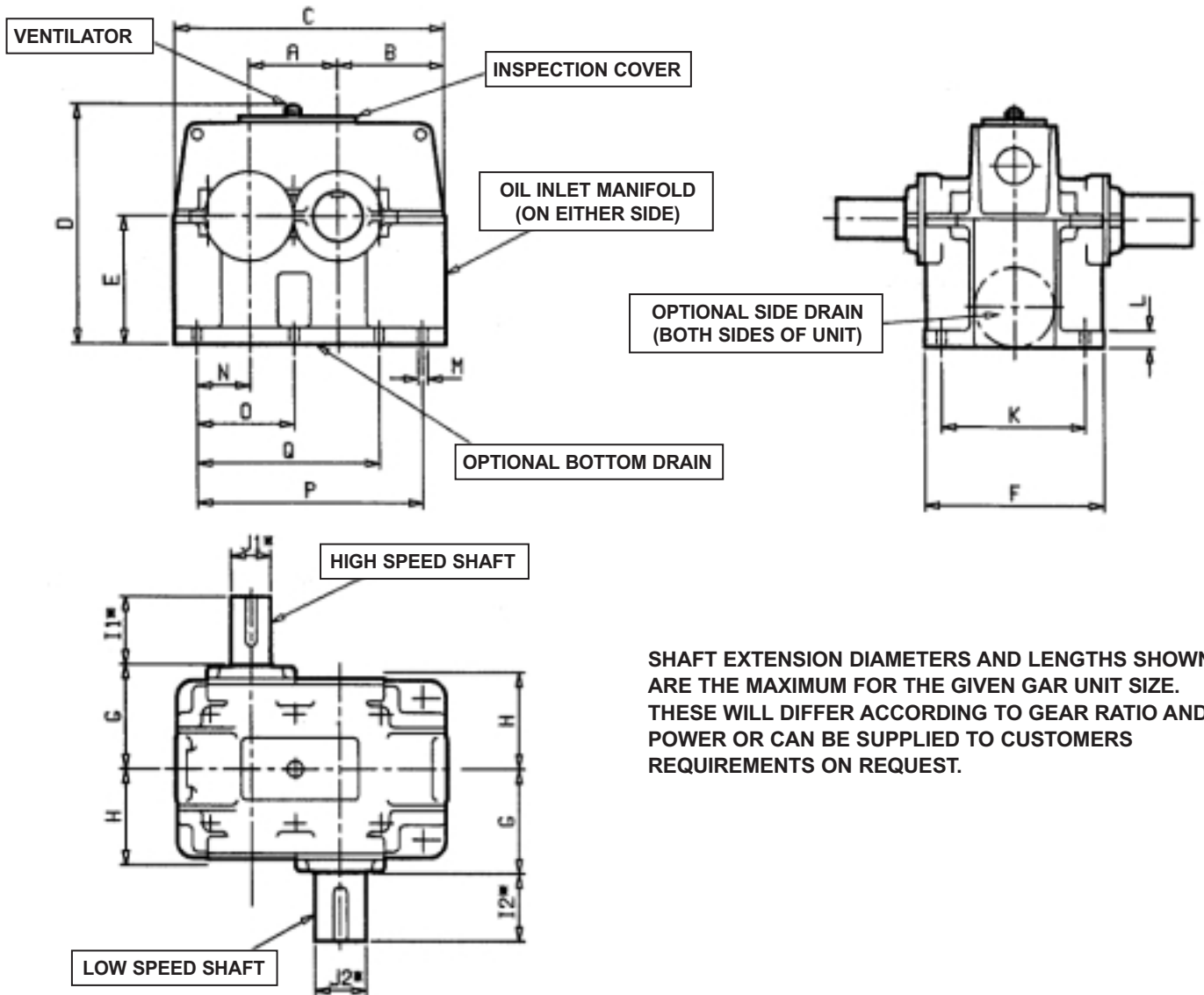

SHAFT EXTENSION DIAMETERS AND LENGTHS SHOWN ARE THE MAXIMUM FOR THE GIVEN GEAR UNIT SIZE. THESE WILL DIFFER ACCORDING TO GEAR RATIO AND POWER OR CAN BE SUPPLIED TO CUSTOMERS REQUIREMENTS ON REQUEST.

UNIT SIZE	A	B	C	D	E	F	G	H	I1" MAX	J1" MAX	I2" MAX	J2" MAX	K	L	Ma	N	O	P	Q	No OF BOLTS	BOLT SIZE
HSGP 200	200	250	640	575	300	440	290	255	165	125	165	125	410	40	22	125	-	510	-	4	M20
HSGP 250	250	300	770	685	355	500	310	278	165	125	165	125	425	50	26	150	-	660	-	4	M24
HSGP 280	280	335	860	765	400	560	320	293	200	140	200	140	450	55	26	170	310	710	-	6	M24
HSGP 315	315	375	955	850	450	630	350	328	240	180	240	180	500	60	33	190	345	800	-	6	M30
HSGP 355	355	400	1045	925	500	710	415	358	280	200	280	200	560	60	33	220	395	900	-	6	M30
HSGP 400	400	450	1180	1035	560	800	450	412	280	220	280	220	630	70	39	240	440	1000	-	6	M36
HSGP 450	450	500	1305	1155	630	850	490	440	330	250	330	250	670	70	39	265	485	1120	-	6	M36
HSGP 500	500	550	1410	1280	710	950	560	510	330	250	330	250	750	70	39	280	530	1250	-	6	M36
HSGP 560	560	595	1560	1415	800	1060	610	575	380	280	380	280	850	75	45	325	600	1400	-	6	M42
HSGP 630	630	685	1780	1600	900	1180	680	640	380	320	380	320	950	80	45	375	640	1600	1300	8	M42
HSGP 710	710	755	1980	1770	1000	1320	710	675	450	340	450	340	1060	80	45	425	710	1800	1450	8	M42

SEE PAGE 16 FOR HANDLING & ROTATION, SHIPPING SPECIFICATION

# HIGH SPEED

## HANDING & ROTATION SHIPPING SPECIFICATION

0109

**Handing and Rotation**

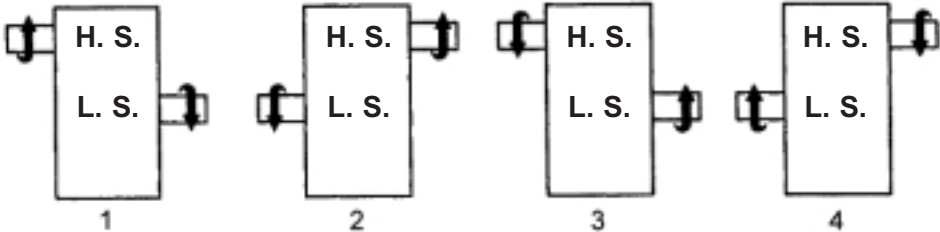

H. S. = HIGH SPEED  
L. S. = LOW SPEED

**Shipping Specification - Kg (approx)**

Unit Size	Type HSGP Net	Gross
200	510	560
250	720	790
280	980	1080
315	1330	1470
355	1770	1950
400	2390	2630
450	3240	3560
500	4020	4430
560	5050	5550
630	6550	7200
710	8500	9350

# HIGH SPEED

## A.G.M.A. STANDARD 421-06 SELECTION PROCEDURE

0109

### A.G.M.A. Standard 421-06 Gearbox Selection

1. Determine the service factor from table 1.
2. Calculate the required power capacity per pinion rpm  

$$= \frac{\text{transmitted power (kW)} \times \text{service factor}}{\text{rpm of pinion}}$$
3. Calculate the gearbox ratio  

$$= \frac{\text{rpm of pinion}}{\text{rpm of wheel}}$$
4. Select gearbox size from Table 2

Table 1 MINIMUM SERVICE FACTOR TABLE			
Application	Prime Mover		
	Motor	Turbine	Internal Combustion Engine
<b>BLOWERS</b>			
Centrifugal	1.4	1.6	1.7
<b>COMPRESSORS</b>			
Centrifugal	1.4	1.6	1.7
Axial	1.4	1.6	1.7
Rotary Lobe (radial, axial, screw, etc )	1.7	1.7	2.0
Reciprocating	2.0	2.0	2.3
<b>FANS</b>			
Centrifugal	1.4	1.6	1.7
Forced Draft	1.4	1.6	1.7
Induced Draft	1.7	2.0	2.2
<b>GENERATORS AND EXCITERS</b>			
Base Load or Continuous	1.1	1.1	1.3
Peak Duty Cycle	1.3	1.3	1.7
<b>PUMPS</b>			
Centrifugal (Alt service except as listed below)	1.3	1.5	1.7
Centrifugal - Boiler feed	1.7	2.0	-
Centrifugal - Hot oil	1.7	2.0	-
High-speed Centrifugal (Over 3600 rpm)	1.7	2.0	-
Centrifugal - Water supply	1.5	1.7	2.0
Rotary - Axial Flow - All types	1.5	1.5	1.8
Rotary -Gear	1.5	1.5	1.8
Reciprocating	2.0	2.0	2.3

See Overleaf for table 2

# HIGH SPEED

## A.G.M.A. STANDARD 421-06

### SELECTION PROCEDURE

0109

A.G.M.A. STANDARD 421-06  
SELECTION PROCEDURE

Table 2 HIGH SPEED GEAR UNITS  
RATING TO A.G.M.A. STANDARD 421-06

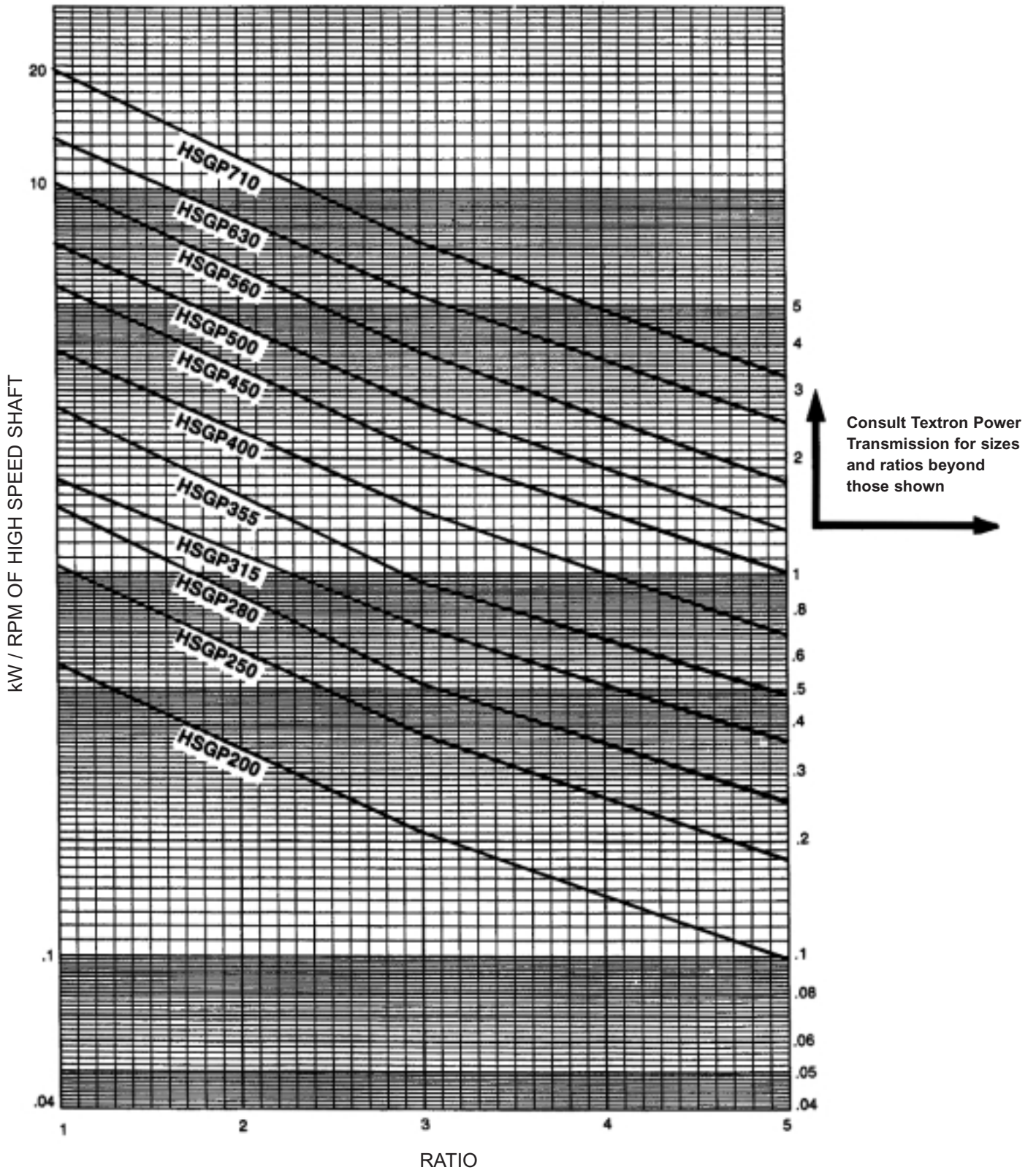

0109

---

## **Other High Speed Options**

# HIGH SPEED

## OTHER AVAILABLE OPTIONS

0109

AS WELL AS THE STANDARD ARRANGEMENTS SHOWN ON PAGES 4 AND 14, OTHER SPECIAL DESIGNS ARE AVAILABLE TO SUIT VARIOUS REQUIREMENTS AND CUSTOMER SPECIFICATIONS. A FEW OF THESE SPECIAL DESIGNS ARE SHOWN BELOW. REFER TO TEXTRON POWER TRANSMISSION FOR FURTHER DETAILS

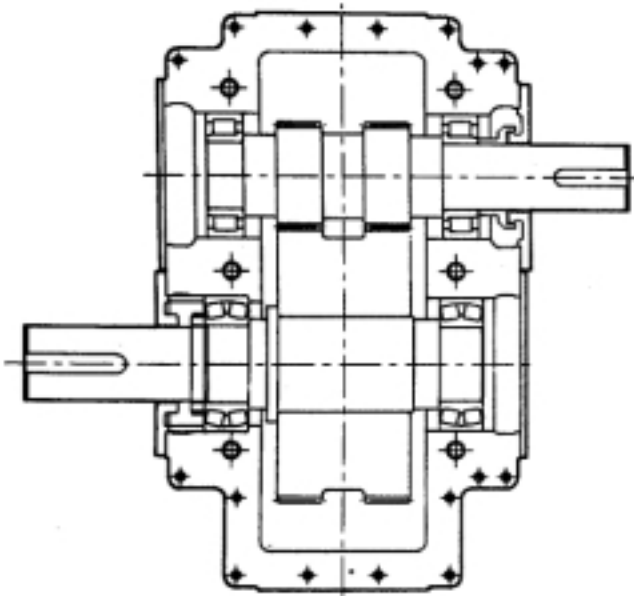

DOUBLE HELICAL GEARING WITH ANTI-FRICTION BEARINGS

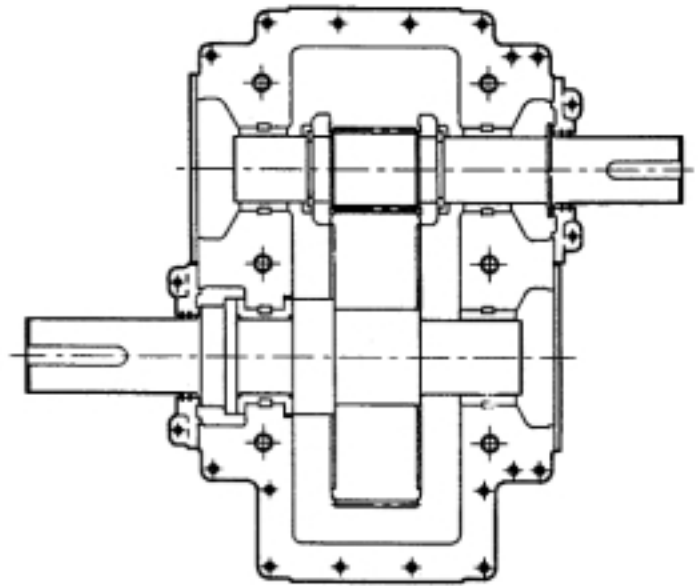

SINGLE HELICAL GEARING WITH THRUST CONES

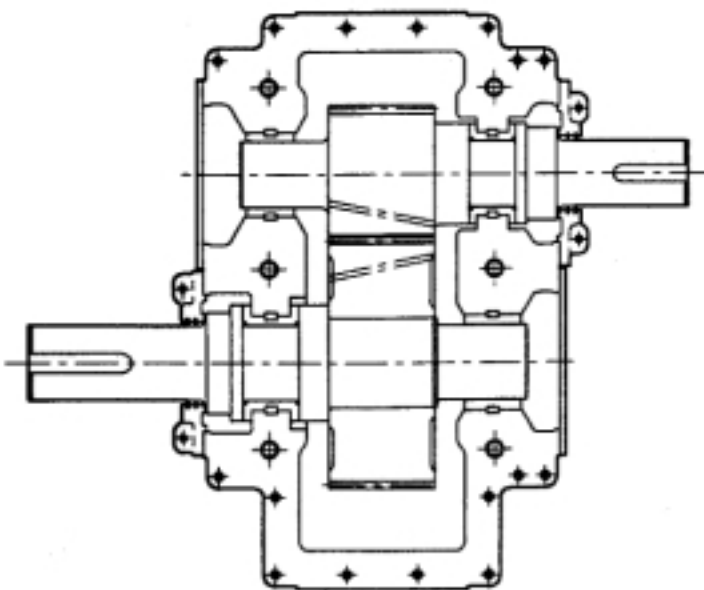

SINGLE HELICAL GEARING WITH TAPER LAND THRUST BEARINGS

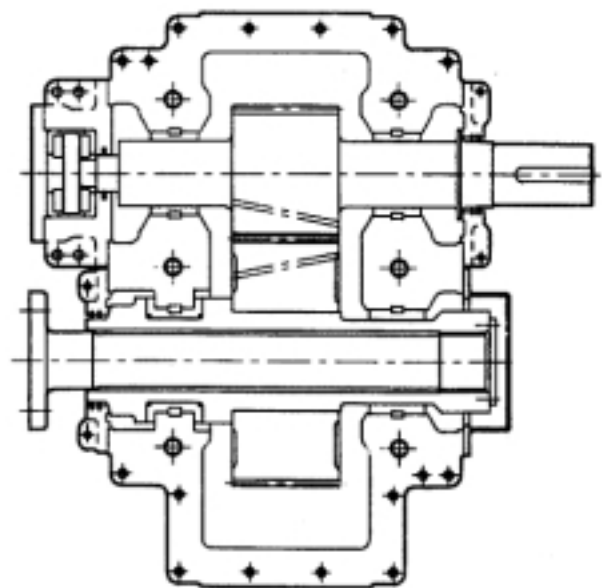

SINGLE HELICAL GEARING WITH QUILL SHAFT ON LOW SPEED LINE

# HIGH SPEED OTHER AVAILABLE OPTIONS

0109

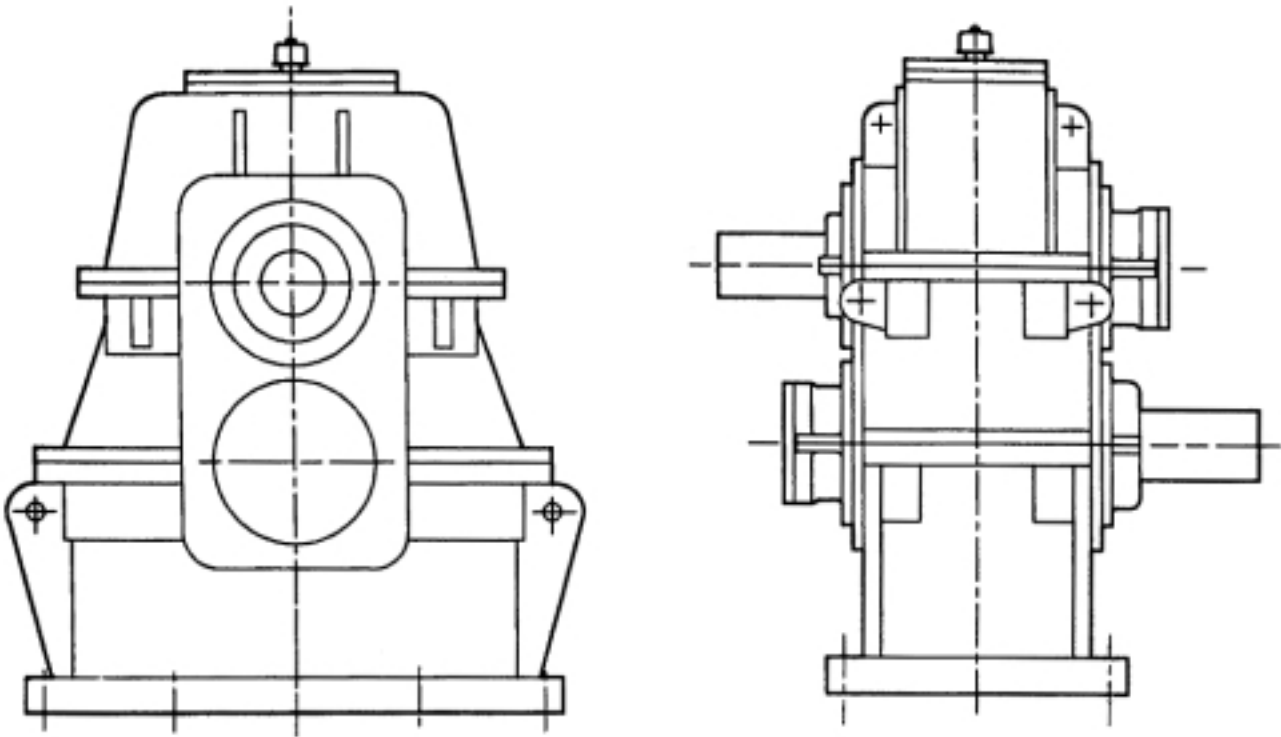

STACK TYPE UNITS - EITHER PINION ABOVE OR WHEEL ABOVE

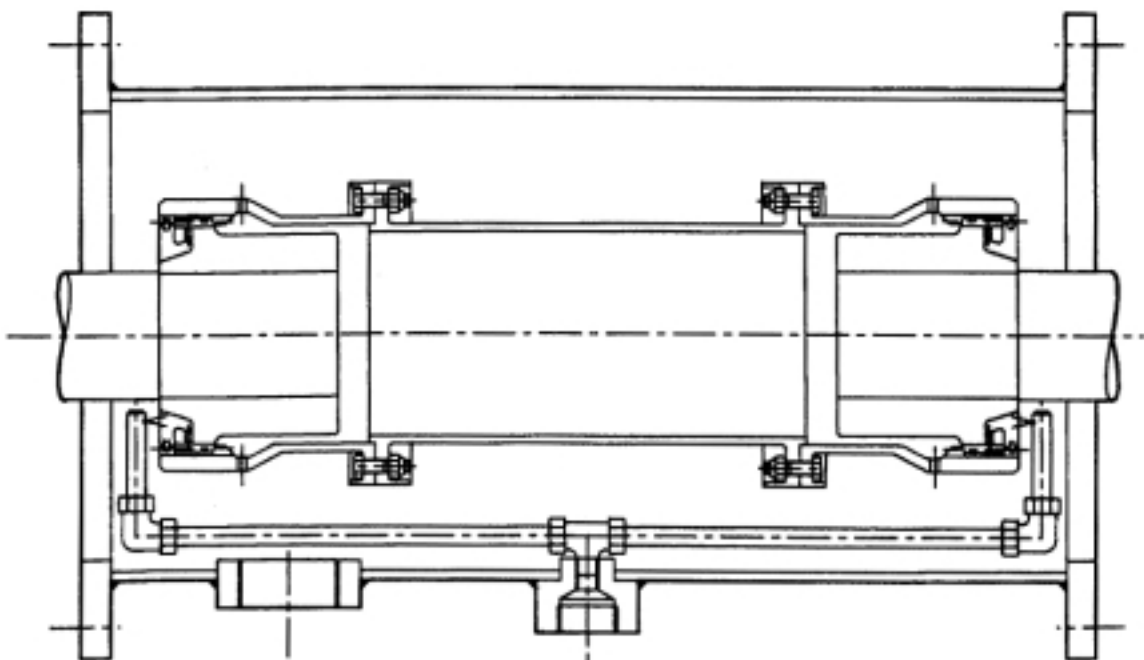

HIGH SPEED GEAR TYPE COUPLINGS

# HIGH SPEED LUBRICATION SYSTEMS

0109

## LUBRICATION SYSTEMS

TEXTRON POWER TRANSMISSION CAN SUPPLY THE LUBRICATION SYSTEM IF REQUIRED. A TYPICAL STANDARD LUBRICATION SYSTEM IS SHOWN HERE

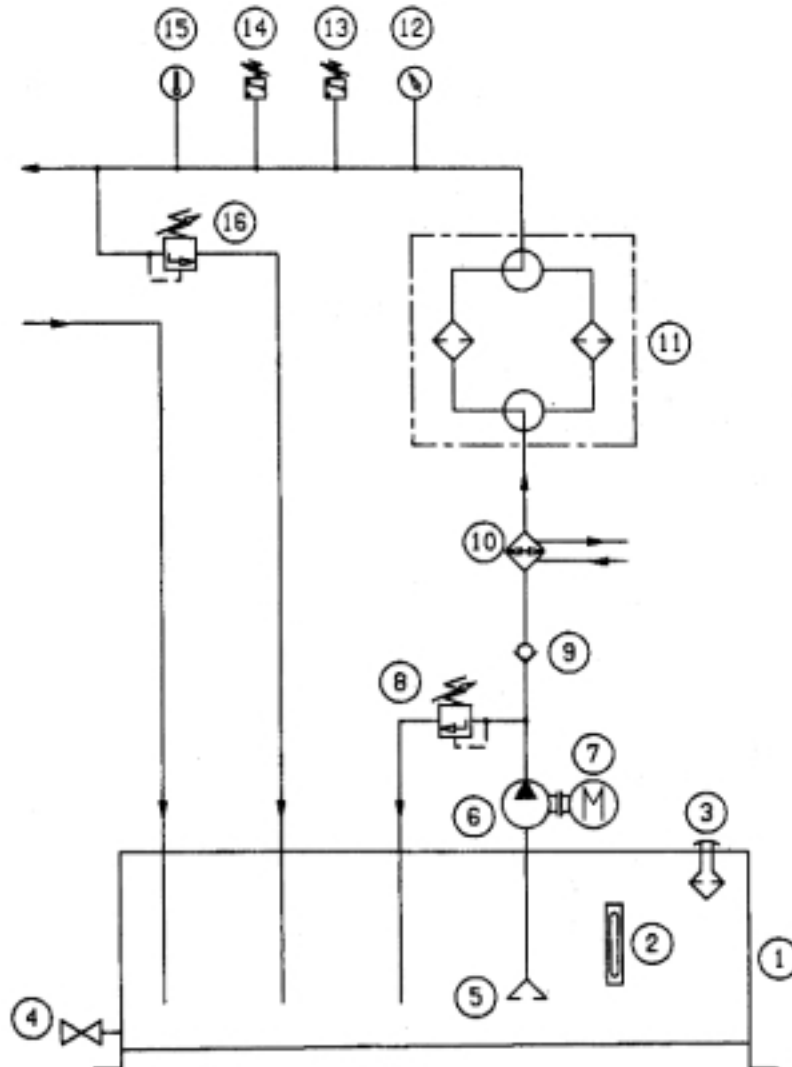

PARTS LIST	
ITEM No	DESCRIPTION
1	OIL RESERVOIR
2	OIL LEVEL INDICATOR
3	FILLER BREATHER
4	OIL DRAIN
5	SUCTION STRAINER
6	PUMP
7	MOTOR
8	PUMP SAFETY RELIEF VALVE
9	NON-RETURN VALVE
10	OIL COOLER
11	OIL FILTER
12	PRESSURE GAUGE
13	HIGH PRESSURE SWITCH
14	LOW PRESSURE SWITCH
15	TEMPERATURE GAUGE
16	SYSTEM RELIEF VALVE

# HIGH SPEED INTEGRAL LUBRICATION SYSTEMS

0109

## INTEGRAL LUBRICATION SYSTEMS

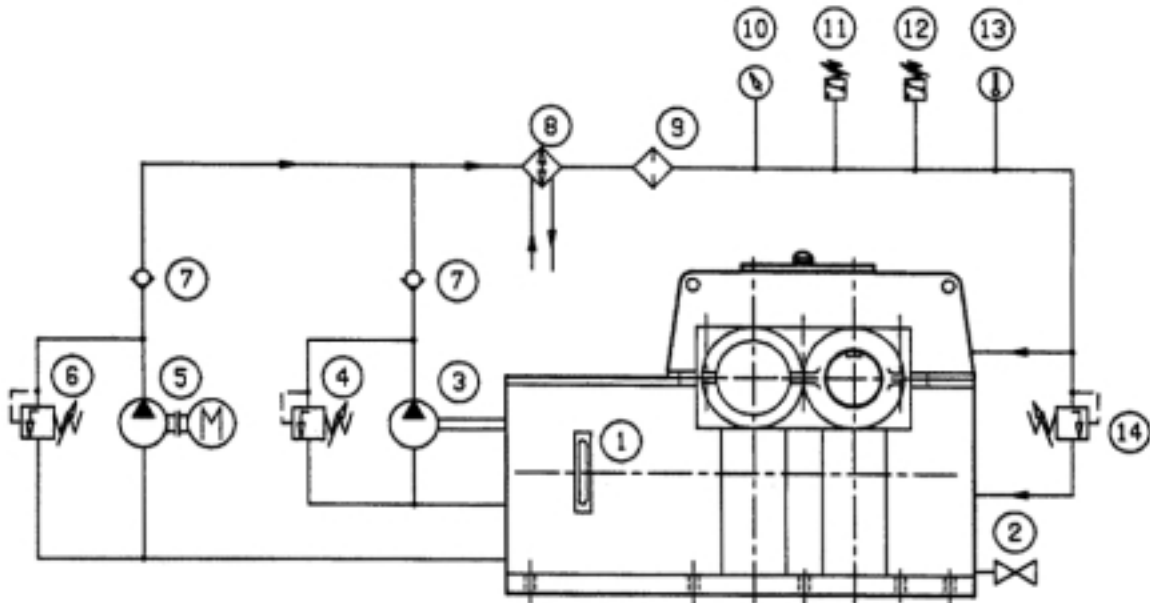

PARTS LIST	
ITEM No	DESCRIPTION
1	OIL LEVEL INDICATOR
2	OIL DRAIN
3	MECHANICALLY DRIVEN PUMP
4	PUMP SAFETY RELIEF VALVE
5	STAND BY MOTORISED PUMP
6	PUMP SAFETY RELIEF VALVE
7	NON-RETURN VALVE
8	OIL COOLER
9	OIL FILTER
10	PRESSURE GAUGE
11	HIGH PRESSURE SWITCH
12	LOW PRESSURE SWITCH
13	TEMPERATURE GAUGE
14	SYSTEM RELIEF VALVE

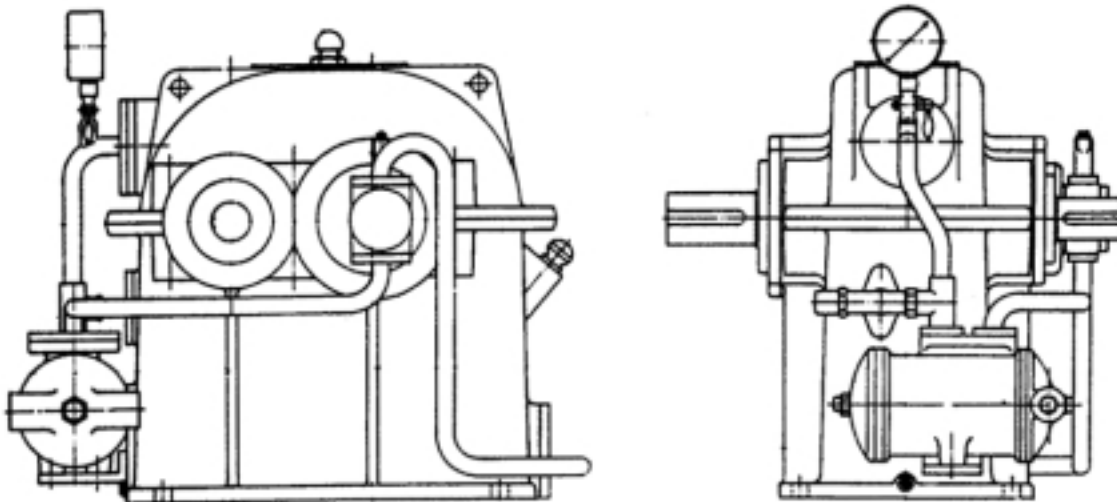

DEEP SUMP GEAR UNITS - AVAILABLE WITH OR  
WITHOUT INTEGRAL LUBRICATION SYSTEM

# HIGH SPEED OTHER AVAILABLE OPTIONS

0109

## OTHER AVAILABLE OPTIONS

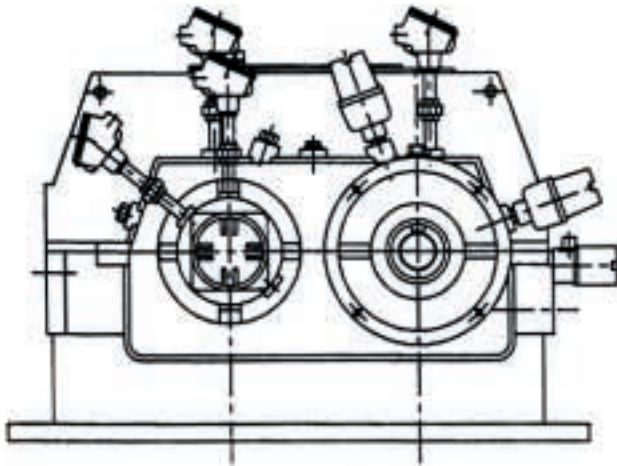

SPECIAL UNIT COMPLETE WITH VIBRATION PROBES, TEMPERATURE PROBES, AND ACCELEROMETER

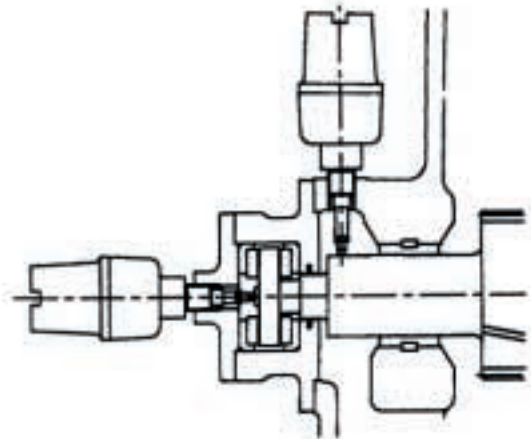

SECTIONAL DETAILS OF AXIAL AND RADIAL VIBRATION PROBES

TEXTRON POWER TRANSMISSION'S UNRIVALLED EXPERIENCE AND COMPUTER AIDED ENGINEERING BACK UP ENABLE US TO OFFER A FULL RANGE OF ROTATING ELEMENT DYNAMIC ANALYSES-CRITICAL SPEED MAPS, NATURAL FREQUENCIES, MODE SHAPES, FREQUENCY RESPONSE CURVES ETC. REFER TO TEXTRON POWER TRANSMISSION FOR FURTHER DETAILS.

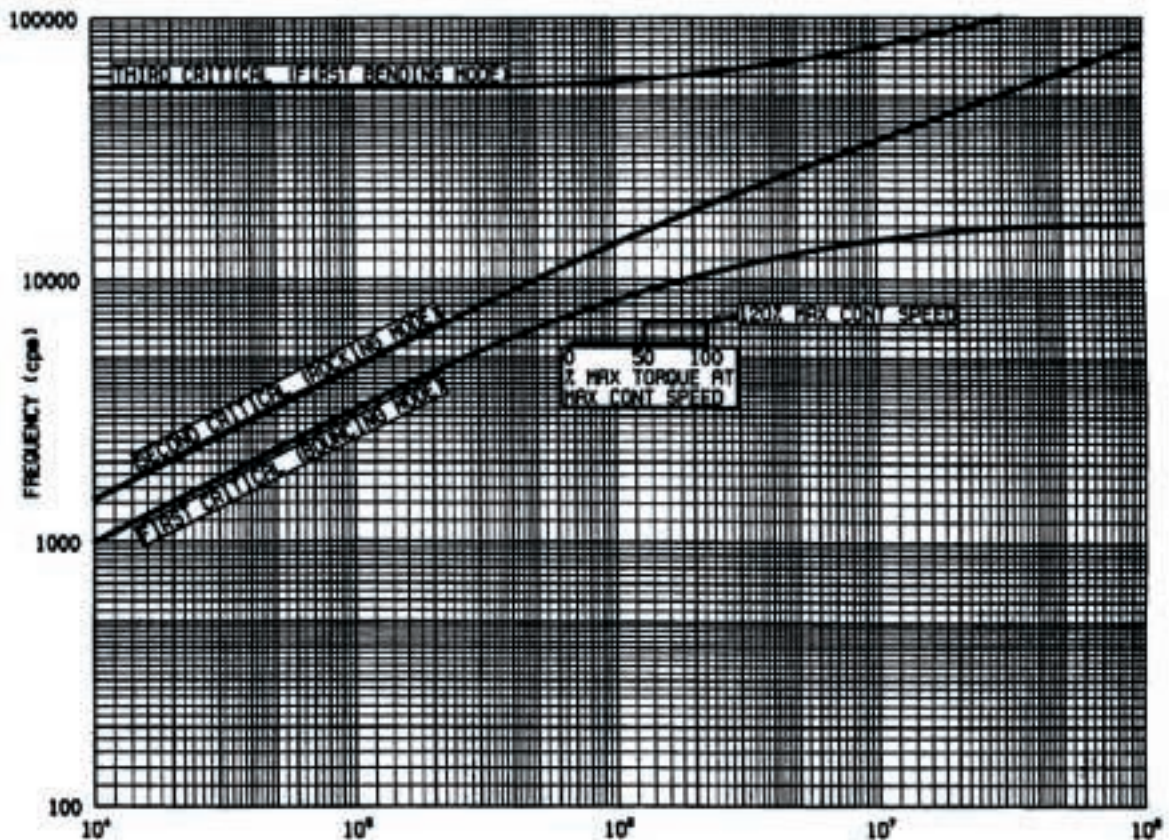

TYPICAL ROTATING ELEMENT LATERAL CRITICAL SPEED MAP



## Уважаемые партнёры!

Компания **КПД** готова предложить комплектующие к оборудованию самого высокого качества.

Основные наши позиции это:

- **Редукторы и мотор-редукторы David Brown / Benzlers** Швеция – это недоступный ранее на украинском рынке уровень качества, надёжности, уровня технических инноваций и технического совершенства. Представлены редукторы всех компоновок.

- **Электродвигатели** асинхронные Brook Crompton, **электромоторы с тормозом** MGM, Италия.

- **Цепи роликовые** приводные и **грузовые** (конвейерные) производства Ketten Wulf, Германия, Sedis, Франция, вильчатые скребковые цепи Sircatene, Италия.

- **Звёздочки для цепей** Sati, Италия

- **Плоские транспортёрные цепи и модульные ленты** Regina

- **Ремни приводные** клиновые, поликлиновые (ручейковые),

вариаторные, круглые, зубчатые специальные, производства компаний **Vando, Япония, Brecoflex, Германия.**

- **Шкивы, монтажные втулки и муфты** со склада, производства компании **Desch, Германия.**

- **Зубчатые цепи** Ramsey, США

- **Гидромуфты** и дисковые тормоза Transfluid, Италия.

- **Карданные валы** Elso/Elbe, Германия, широкий диапазон конструкций и размеров, крестовины карданных валов.

- **СТS обгонные муфты** из Италии. Высокое качество изготовления.

Наши специалисты всегда готовы помочь решить проблемы эксплуатации оборудования и предложить надёжные комплектующие.

С уважением,

Павинов Михаил

инженер

ООО «Компания промышленных деталей»

(098) 083-58-09

[misha@motor-reduktor.com.ua](mailto:misha@motor-reduktor.com.ua)

[www.motor-reduktor.com.ua](http://www.motor-reduktor.com.ua)



## IMPORTANT

### Product Safety Information

**General** - The following information is important in ensuring safety. It must be brought to the attention of personnel involved in the selection of Textron Power Transmission equipment, those responsible for the design of the machinery in which it is to be incorporated and those involved in its installation, use and maintenance.

Textron Power Transmission equipment will operate safely provided it is selected, installed, used and maintained properly. As with any power transmission equipment **proper precautions must** be taken as indicated in the following paragraphs, to ensure safety.

**Potential Hazards** - these are not necessarily listed in any order of severity as the degree of danger varies in individual circumstances. It is important therefore that the list is studied in its entirety:-

- 1) Fire/Explosion
  - (a) Oil mists and vapour are generated within gear units. It is therefore dangerous to use naked lights in the proximity of gearbox openings, due to the risk of fire or explosion.
  - (b) In the event of fire or serious overheating (over 300 °C), certain materials (rubber, plastics, etc.) may decompose and produce fumes. Care should be taken to avoid exposure to the fumes, and the remains of burned or overheated plastic/rubber materials should be handled with rubber gloves.
- 2) Guards - Rotating shafts and couplings must be guarded to eliminate the possibility of physical contact or entanglement of clothing. It should be of rigid construction and firmly secured.
- 3) Noise - High speed gearboxes and gearbox driven machinery may produce noise levels which are damaging to the hearing with prolonged exposure. Ear defenders should be provided for personnel in these circumstances. Reference should be made to the Department of Employment Code of Practice for reducing exposure of employed persons to noise.
- 4) Lifting - Where provided (on larger units) only the lifting points or eyebolts must be used for lifting operations (see maintenance manual or general arrangement drawing for lifting point positions). Failure to use the lifting points provided may result in personal injury and/or damage to the product or surrounding equipment. Keep clear of raised equipment.
- 5) Lubricants and Lubrication
  - (a) Prolonged contact with lubricants can be detrimental to the skin. The manufacturer's instruction must be followed when handling lubricants.
  - (b) The lubrication status of the equipment must be checked before commissioning. Read and carry out all instructions on the lubricant plate and in the installation and maintenance literature. Heed all warning tags. Failure to do so could result in mechanical damage and in extreme cases risk of injury to personnel.
- 6) Electrical Equipment - Observe hazard warnings on electrical equipment and isolate power before working on the gearbox or associated equipment, in order to prevent the machinery being started.
- 7) Installation, Maintenance and Storage
  - (a) In the event that equipment is to be held in storage, for a period exceeding 6 months, prior to installation or commissioning, Textron Power Transmission must be consulted regarding special preservation requirements. Unless otherwise agreed, equipment must be stored in a building protected from extremes of temperature and humidity to prevent deterioration. The rotating components (gears and shafts) must be turned a few revolutions once a month (to prevent bearings brinelling).
  - (b) External gearbox components may be supplied with preservative materials applied, in the form of a "waxed" tape overwrap or wax film preservative. Gloves should be worn when removing these materials. The former can be removed manually, the latter using white spirit as a solvent.

Preservatives applied to the internal parts of the gear units do not require removal prior to operation.
  - (c) Installation must be performed in accordance with the manufacturer's instructions and be undertaken by suitably qualified personnel.
  - (d) Before working on a gearbox or associated equipment, ensure that the load has been removed from the system to eliminate the possibility of any movement of the machinery and isolate power supply. Where necessary, provide mechanical means to ensure the machinery cannot move or rotate. Ensure removal of such devices after work is complete.
  - (e) Ensure the proper maintenance of gearboxes in operation. Use only the correct tools and Textron Power Transmission approved spare parts for repair and maintenance. Consult the Maintenance Manual before dismantling or performing maintenance work.
- 8) Hot Surfaces and Lubricants
  - (a) During operation, gear units may become sufficiently hot to cause skin burns. Care must be taken to avoid accidental contact.
  - (b) After extended running the lubricant in gear units and lubrication systems may reach temperatures sufficient to cause burns. Allow equipment to cool before servicing or performing adjustments.
- 9) Selection and Design
  - (a) Where gear units provide a backstop facility, ensure that back-up systems are provided if failure of the backstop device would endanger personnel or result in damage.
  - (b) The driving and driven equipment must be correctly selected to ensure that the complete machinery installation will perform satisfactorily, avoiding system critical speeds, system torsional vibration, etc.
  - (c) The equipment must not be operated in an environment or at speeds, powers, torques or with external loads beyond those for which it was designed.
  - (d) As improvements in design are being made continually the contents of this catalogue are not to be regarded as binding in detail, and drawings and capacities are subject to alterations without notice.

The above guidance is based on the current state of knowledge and our best assessment of the potential hazards in the operation of the gear units.

Any further information or clarification required may be obtained by contacting Textron Power Transmission.

Agriculture

Automotive

Cement

Chemical

Construction

Defence

Energy

Food & Beverage

Forestry

Marine

Metals

Mining

Pulp & Paper

Quarrying

Rail

Rubber & Plastics

Textiles

Transportation

Water

Wind Energy



Global manufacturing capability

Asia Pacific	+61 2 4283 0300
Central Europe	+31 77 324 5900
China	+86 21 6235 0363
Eastern Europe	+43 7229 61891
France	+33 3 89 37 0113
Scandinavia	+46 42 18 6800
South Africa	+27 11 748 0000
UK	+44 1484 465610
USA	+1 513 554 1811

[www.TextronPT.com](http://www.TextronPT.com)

**TEXTRON** POWER TRANSMISSION