

Series M Helical In Line



Technical
Up to - 90kW / 110,000 Nm

Gear Motors
CM-1.02GBD1009



Уважаемые партнёры!

Компания **КПД** готова предложить комплектующие к оборудованию самого высокого качества.

Основные наши позиции это:

- **Редукторы и мотор-редукторы David Brown / Benzlers** Швеция – это недоступный ранее на украинском рынке уровень качества, надёжности, уровня технических инноваций и технического совершенства. Представлены редукторы всех компоновок.

- **Электродвигатели** асинхронные Brook Crompton, **электромоторы с тормозом** MGM, Италия.

- **Цепи роликовые** приводные и **грузовые** (конвейерные) производства Ketten Wulf, Германия, Sedis, Франция, вильчатые скребковые цепи Sircatene, Италия.

- **Звёздочки для цепей** Sati, Италия

- **Плоские транспортёрные цепи и модульные ленты** Regina

- **Ремни приводные** клиновые, поликлиновые (ручейковые),

вариаторные, круглые, зубчатые специальные, производства компаний **Vando, Япония, Brecoflex, Германия.**

- **Шкивы, монтажные втулки и муфты** со склада, производства компании **Desch, Германия.**

- **Зубчатые цепи** Ramsey, США

- **Гидромуфты** и дисковые тормоза Transfluid, Италия.

- **Карданные валы** Elso/Elbe, Германия, широкий диапазон конструкций и размеров, крестовины карданных валов.

- **СТS обгонные муфты** из Италии. Высокое качество изготовления.

Наши специалисты всегда готовы помочь решить проблемы эксплуатации оборудования и предложить надёжные комплектующие.

С уважением,

Павинов Михаил

инженер

ООО «Компания промышленных деталей»

(098) 083-58-09

misha@motor-reduktor.com.ua

www.motor-reduktor.com.ua



Каталог мотор-редукторов SERIES M

David Brown / Benzlers Radicon

Serving an entire spectrum of mechanical drive applications from food, energy, mining and metal; to automotive, aerospace and marine propulsion, we are here to make a positive difference to the supply of drive solutions.

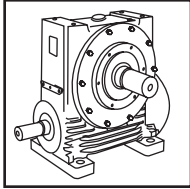

Series A
Worm Gear units
and geared motors
in single & double
reduction types

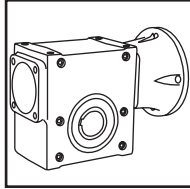

Series B
Conex helicoidal
gear geometry right
angle gearmotors
and reducers

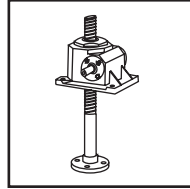

Series BD
Screwjack worm
gear unit

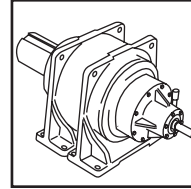

HTP
High torque
planetary gear units

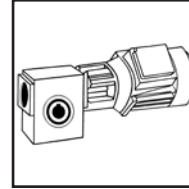

Series BS
Worm gear unit

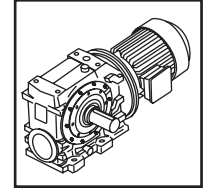

Series C
Right angle drive
helical worm geared
motors & reducers

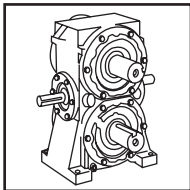

DuoDrive
Dual gears on
parallel output
shafts

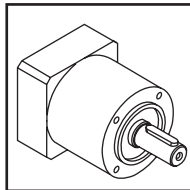

Series E
Economical
planetary servo
gearboxes

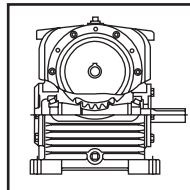

Extruder Drive
Rugged duty
reducer takes high
screw pressure

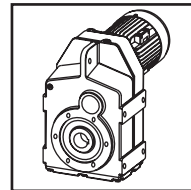

Series F
Parallel angle
helical bevel helical
geared motors &
reducers

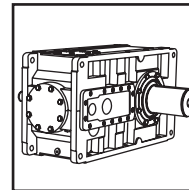

Series G
Helical parallel shaft
& bevel helical right
angle drive gear
units

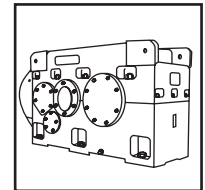

Series H
Large helical
parallel shaft &
bevel helical right
angle drive units

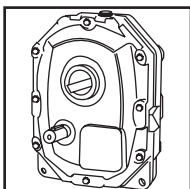

Series J
Shaft mounted
helical speed
reducers

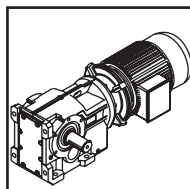

Series K
Right angle helical
bevel helical geared
motors & reducers

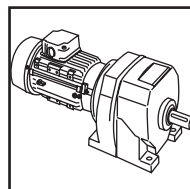

Series M
In-line helical
geared motors &
reducers

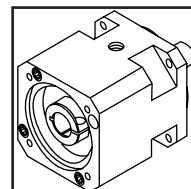

Series P
Precision planetary
servo gearboxes

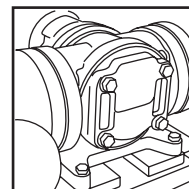

Roloïd Gear Pump
Lubrication and fluid
transportation pump

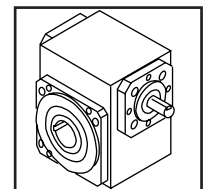

Series W
Precision right angle
servo gearboxes

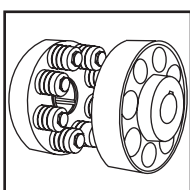

**Series X
Cone Ring**
Pin and bush
elastomer coupling

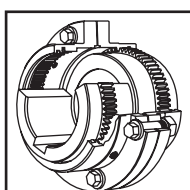

**Series X
Gear**
Torsionally rigid,
high torque coupling

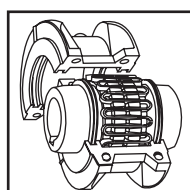

**Series X
Grid**
Double flexing steel
grid coupling

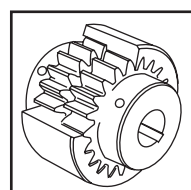

**Series X
Nylicon**
Gear coupling with
nylon sleeve

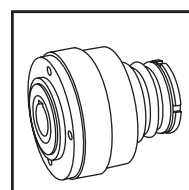

**Series X
Torque Limiter**
Overload protection
device



We offer a wide range of repair services and many years experience of repairing demanding and highly critical transmissions in numerous industries.

We can create custom engineered transmission solutions of any size and configuration.

ATEX Compliance Assured



Total compliance with the ATEX Directive safeguarding the use of industrial equipment in potentially explosive atmospheres is assured for users of our geared products.

Certification is available for standard gearboxes and geared motors with badging displaying the CE Mark and the Ex mark, name and location of the manufacturer, designation of series or type, serial number, year of manufacture, Ex symbol and equipment group/category.

ATEX directive 94/9/EC (also known as ATEX 95 or ATEX 100A) and the CE Marking Directive are enforced in all EC member states. Compliance is compulsory for designers, manufacturers or suppliers of electrical and non-electrical equipment for use in potentially explosive atmospheres created by the presence of flammable gases, vapours, mists or dusts.

Ex compliant standard gearboxes can be supplied against Groups 2 or 3 for surface industries in designated hazardous location Zones 1 and 2 for gases, vapours and mists; and in Zones 21 and 22 for dusts.

SERIES M

CONTENTS

General Description _____	1
Unit Designations _____	2
Explanation and use of Ratings and Service Factors _____	3
Load Classification by Applications _____	4
Selection Procedure _____	5 - 6
Unit Versions - Column 9 Entry _____	7
Output Shaft Options - Column 11 Entry _____	8
Motor Adaptors - Column 12 Entry _____	9 - 12
Lubrication _____	13
Mounting Positions - Column 13 and 14 Entry _____	14
MOTORISED	
Motor Performance Data _____	16
Motor Details _____	17
Additional Motor Features - Column 19 Entry _____	18
Additional Gearbox Features - Column 20 Entry _____	19
Selection Tables - Geared Motors _____	20 - 80
Dimension Sheets - Geared Motors _____	81 - 88
Motorised Backstop Module _____	89
REDUCER	
Overhung & Axial Loads on Shafts _____	91 - 92
Ratings - Input Power / Output Torque _____	93 - 103
Dimension Sheets - Speed Reducers _____	104 - 111
C-Flange (B14) Mounting Dimensions _____	112
Thermal Power Ratings / Dimensions of Units with Fans _____	113 - 114
Reducer Backstop Module _____	115
Shipping Specification _____	116 - 117

SERIES M

GENERAL DESCRIPTION

Series M inline geared motors and reducers provide a very efficient and compact drive solution to meet most requirements up to 90kW with maximum output torque capacity of 11000Nm.

The range takes advantage of many years of accumulated design expertise, together with the use of high quality materials and components. The end result is a series of speed reducing and geared motors offering high load carrying capacity, high efficiency, quiet running and reliability.

The Range Includes

Twelve sizes of unit with a ratio coverage of 1.4/1 to 70/1 in double reduction and up to 250/1 in triple reduction and 16200/1 in combined units.

Unit Versions Available

- Base Mounted
- B5 (D) Flange Mounted
- B14 (C) Flange Mounting
- Base Mount and B14 (C) Flange Mounting

- Unit type M - Motorised with IEC standard motor
- Unit type N - Motorised with NEMA standard motor
- Unit type H - Motorised with IEC high efficiency motor (EFF1 or EPACK)
- Unit type E - Motorised with NEMA high efficiency motor (EPACK)
- Unit type G - Unit to allow fitting of a standard IEC motor

Unit type A - Unit to allow fitting of NEMA motor

- Unit type R - Reducer unit
- Unit type S - Reducer unit with fan kit
- Unit type W - Reducer unit with backstop CCW rotation
- Unit type X - Reducer unit with backstop CW rotation
- Unit type Y - Reducer unit with fan and backstop CW rotation
- Unit type Z - Reducer unit with fan and backstop CCW rotation

Design Features Include

- Patented standard motor connection (IEC or NEMA).
- Ability to fit double oil seal input and output as required.
- All units being suitable to fit IEC or NEMA standard motors.
- All units are dimensionally interchangeable with other major manufacturers.
- Brake geared motors are available as standard.
- Sizes 01, 02, 03, 04, 05, 06 and 07 are all supplied with lubricant.
- Sizes 08, 09, 10, 13 and 14 are supplied without lubricant.
- Motorised units can be fitted with a backstop module and reducer units can be fitted with a backstop and fan.

As improvements in design are being made continually this specification is not to be regarded as binding in detail and drawings and capacities are subject to alteration without notice. Certified drawings will be sent on request.

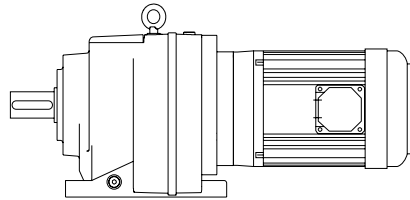

Two stage base mounted motorised

* M 0 3 2 2 8 . 0 B M C - 1 A . 7 5 A - -

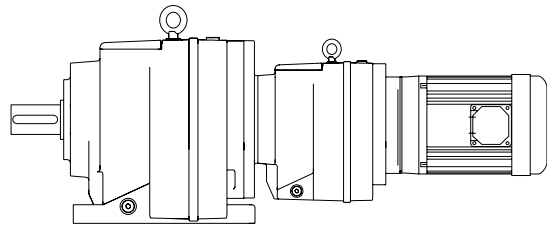

Four stage base mounted motorised

* M 0 6 4 2 2 5 0 B M C - 1 A . 1 8 A - -

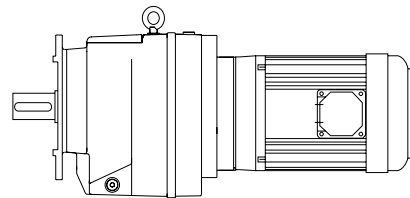

Three stage flange mounted motorised

* M 0 6 3 2 1 2 5 L M C - 1 A . 7 5 A - -

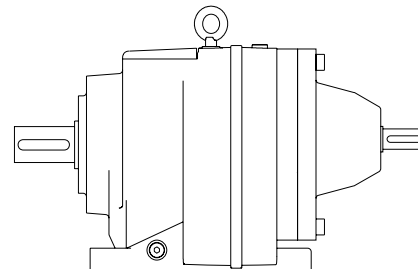

Two stage base mounted reducer

* M 0 7 2 2 7 1 . B R C - 1 - - - - -

* Typical unit designations

SERIES M

UNIT DESIGNATIONS

Gearbox Codes														Motor Codes						
Series	Size of Unit			No of Reductions	Revision Version	Nominal Overall Ratio			Unit Version	Type of Unit	Output Shaft	Motor Adaptor	Mounting Position	Geared Motor Power			No of Motor Poles	Additional Motor Features	Additional Gearbox Features	
1	2	3	4	5	6	7	8	9	10	11	12	13	14	15	16	17	18	19	20	
M																				
M	0	3	2	2	8	.	0	B	M	C	-	1	A	.	7	5	A	-	-	

* Example

1 - Series M

Range **M**

2, 3 - Size of Unit

0 1 Through **1 4**

4 - No of Reductions

2 Through **5**

5 - Revision Version

2 For Sizes 01 to 08
1 For Sizes 09 to 14

6, 7, 8 - Nominal Overall Ratio

eg **8 . 0** See Pages 93 - 103

9 Unit Version

B - Base Mounted
B5 (D) Flange Mounted
E - B14 (C) Flange Mounting
V - Base and B14 (C) Flange Mounting
(Non - Standard Special Orders Only)

Letter Entry Depends on Flange Diameter See Page 7

10 - Type of Unit

M - Motorised with IEC standard motor
N - Motorised with NEMA standard motor
H - Motorised with IEC high efficiency motor (EFF1 or EPACT)
E - Motorised with NEMA high efficiency motor (EPACT)
G - Unit to allow fitting of IEC motor (non customer motor)
A - Unit to allow fitting of NEMA motor (non customer motor)
R - Reducer unit
S - Reducer unit with fan kit
W - Reducer unit with backstop CCW rotation
X - Reducer unit with backstop CW rotation
Y - Reducer unit with fan and backstop CW rotation
Z - Reducer unit with fan and backstop CCW rotation

20 - Additional Gearbox Features

Double Oil Seal, Motorised Backstop Etc

eg **- F** See Page 20

19 - Additional Motor Features

eg **- A** See Page 19

For Types Without Motor

Enter **-**

18 - No of Motor Poles

- No motor

		50 Hz		60 Hz
4 Pole (Std)	1500 rpm	A	1800 rpm	B
4 Pole (High)	1500 rpm	K	1800 rpm	L
6 Pole (Std)	1000 rpm	C	1200 rpm	D
6 Pole (High)	1000 rpm	M	1200 rpm	N
2 Pole	3000 rpm	E	3600 rpm	F
8 Pole	750 rpm	G	900 rpm	H

S Dual speed or special motor

15, 16, 17 - Geared Motor Powers

Motor Power Required

eg **. 7 5** See Page 21 - 81

For reducer and non standard

motor types enter **- - -**

13, 14 - Mounting Position

eg **2 B** See Page 15

12 - Motor Adaptor For Unit Types Column 10 Entries M, N, H, E, G or A

See Pages 9 to 13

For All Other Types Enter **-**

11 - Output Shaft

C - Standard See Page 8

N - Inch

* This Page May Be Photocopied Allowing The Customer To Enter Their Order

To access the on line configurator please visit www.swift-gears.com for a hard copy version authorised distributors can visit www.swift-distributors.com and view our Engineering Document ENG 07-01-014.

SERIES M

EXPLANATION & USE OF RATINGS & SERVICE FACTORS

Gear unit selection is made by comparing actual loads with catalogue ratings. Catalogue ratings are based on a standard set of loading conditions, whereas actual load conditions vary according to type of application. Service Factors are therefore used to calculate an equivalent load to compare with catalogue ratings.

i.e. Equivalent Load = Actual Load x Service Factor

Mechanical ratings and service factors Fm and Fs

Mechanical ratings measure capacity in terms of life and/or strength, assuming 10 hr/day continuous running under uniform load conditions.

Catalogue ratings allow 100% overload at starting, braking or momentarily during operation up to 10 hours per day.

The unit selected must therefore have a catalogue rating at least equal to half maximum overload.

Mechanical Service Factor Fm (Table 1) is used to modify the actual load according to daily operating time, and type of loading.

Load characteristics for a wide range of applications are detailed in Table 3 opposite, which are used in deciding the appropriate Service Factor Fm from Table 1.

If overloads can be calculated, or accurately assessed, actual loads should be used instead of Fm.

For units subjected to frequent stop/starts overloads in excess of 10 times/day multiply factor Fm x Factor Fs (table 2).

For applications where units are to operate in extremely dusty or moist/humid atmospheres unit selection should be referred to our application engineers.

Table 1. Mechanical Service Factor (Fm)

Prime mover	Duration of service-hrs per day	Load classification-driven machine		
		Uniform mass acceleration factor ≤ 0.2	Moderate mass acceleration factor ≤ 3	Heavy mass acceleration factor ≤ 10
Electric motor, steam turbine or hydraulic motor	Under 3	0.80	1.00	1.50
	3 to 10	1.00	1.25	1.75
	Over 10	1.25	1.50	2.00
Multi-cylinder internal combustion engine	Under 3	1.00	1.25	1.75
	3 to 10	1.25	1.50	2.00
	Over 10	1.50	1.75	2.25
Single cylinder internal combustion engine	Under 3	1.25	1.50	2.00
	3 to 10	1.50	1.75	2.25
	Over 10	1.75	2.00	2.50

$$\text{Mass acceleration factor} = \frac{\text{all external moments of inertia}^*}{\text{moment of inertia of driving motor}}$$

* calculated with reference to the motor speed

Table 2. Number of Starts Factor (Fs)

Start / Stops per hour (1)	Up to 1	5	10	40	60	≥ 200
Factor Fs	1.00	1.03	1.06	1.10	1.15	1.20

Note: (1) Intermediate values are obtained by linear interpolation

SERIES M

SELECTION PROCEDURE FOR MOTORISED UNITS

EXAMPLE APPLICATION DETAILS

Absorbed power of driven machine = 0.7 kW
 Output speed of gearbox or Input speed of machine = 63 rev/min
 Application = Uniformly loaded belt conveyor
 Duration of service (hours per day) = 24hrs
 Mounting position = 1
 Ambient temperature = 20°C
 Running time (%) = 100%

1 DETERMINE MECHANICAL SERVICE FACTOR (Fm)

Refer to Load Classification by Application, table 3, page 4
 Application = Uniformly loaded belt conveyor

Conveyors-uniformly loaded or fed		
apron	U	U = Uniform load
assembly	U	
belt	U	
bucket	U	
chain	U	

Refer to mechanical service factor (Fm), table 1, page 3
 Duration of service (hours per day) = 24hrs

Prime mover	Duration of service-hrs per day	Load classification-drive	
		Uniform	Moderate
Electric motor, steam turbine or hydraulic motor	Under 3	0.80	1.00
	3 to 10	1.00	1.25
	Over 10	1.25	1.50

Therefore mechanical service factor (Fm) = 1.25

If the unit is subject to frequent start/stops Fm must be multiplied by factor Fs (see table 2 page 3)

2 DETERMINE REQUIRED OUTPUT TORQUE AT GEARBOX OUTPUTSHAFT

$$\text{Absorbed output torque} = \frac{\text{Absorbed power} \times 9550}{\text{Gearbox output speed}}$$

$$\frac{0.7 \times 9550}{63} = 106 \text{ Nm}$$

3 SELECT GEARED MOTOR

Refer to selection table one motor size larger than absorbed power.
 Absorbed power = 0.7 kW, therefore refer to 0.75 kW selection table, page 34
 Always select from 4 POLE selection table in the first instance as this offers a more economical solution.
 Required output speed of gearbox = 63 rev/min

0.75 kW	N2 R/MIN	i	M2 Nm	Fm	N	UNIT DESIGNATION	Kg	Motor Frame Size
	Output Speed	Ratio	Output Torque	Service Factor	Overhung Load	Column Entry <input type="text" value="1"/> Through <input type="text" value="20"/> Spaces to be filled when entering order	Weight of Base Mount Unit	
4 POLE	177	8	39	3.47	4000	M 0 2 2 2 8 . 0 _ M _ _ _ . 7 5 A - -	22.5	80A
	156	9.09	44	3.14	4000	9 . 0		
	127	11.15	54	2.65	4000	1 1 .		
	114	12.37	60	2.45	4000	1 2 .		
	101	14.05	68	2.22	4000	1 4 .		
	89	15.97	78	2.04	3968	1 6 .		
	80	17.58	85	1.86	3878	1 8 .		
	70	20.23	99	1.61	3757	2 0 .		
	64	21.99	107	1.48	4000	2 2 .		
	54	26.4	128	1.24	3847	2 8 .		

4 CHECK OUTPUT TORQUE

Output torque (M2) of selected unit must be equal or more than required output torque at gearbox outputshaft.
 Required output torque at gearbox outputshaft = 106 Nm

0.75 kW	N2 R/MIN	i	M2 Nm	Fm	N	UNIT DESIGNATION	Kg	Motor Frame Size
	Output Speed	Ratio	Output Torque	Service Factor	Overhung Load	Column Entry <input type="text" value="1"/> Through <input type="text" value="20"/> Spaces to be filled when entering order	Weight of Base Mount Unit	
4 POLE	177	8	39	3.47	4000	M 0 2 2 2 8 . 0 _ M _ _ _ . 7 5 A - -	22.5	80A
	156	9.09	44	3.14	4000	9 . 0		
	127	11.15	54	2.65	4000	1 1 .		
	114	12.37	60	2.45	4000	1 2 .		
	101	14.05	68	2.22	4000	1 4 .		
	89	15.97	78	2.04	3968	1 6 .		
	80	17.58	85	1.86	3878	1 8 .		
	70	20.23	99	1.61	3757	2 0 .		
	64	21.99	107	1.48	4000	2 2 .		
	54	26.4	128	1.24	3847	2 8 .		

Selected unit's output torque (M2) = 107 Nm, therefore unit is acceptable

Go to point 5

SERIES M

SELECTION PROCEDURE FOR MOTORISED UNITS

5 CHECK SERVICE FACTOR

Service factor (Fm) of selected unit must be equal or more than required service factor.

Required service factor of gearbox = 1.25

0.75 kW	N2 R/MIN	i	M2 Nm	Fm	N	UNIT DESIGNATION Column Entry 1 Through 20 Spaces to be filled when entering order	Kg	Motor Frame Size
	Output Speed	Ratio	Output Torque	Service Factor	Overhung Load			
4 POLE	177	8	39	3.47	4000	M 0 2 2 2 8 . 0 _ M _ _ _ . 7 5 A - -	22.5	80A
	156	9.09	44	3.14	4000	9 . 0		
	127	11.15	54	2.65	4000	1 1 .		
	114	12.37	60	2.45	4000	1 2 .		
	101	14.05	68	2.22	4000	1 4 .		
	89	15.97	78	2.04	3968	1 6 .		
	80	17.58	85	1.86	3878	1 8 .		
	70	20.23	99	1.61	3757	2 0 .		
	64	21.99	107	1.48	4000	2 2 .		
	54	26.4	128	1.24	3847	2 8 .		

Selected unit's service factor (Fm) = 1.48, therefore unit is acceptable.

Alternatively a M03 unit could be selected which has a greater service factor

0.75 kW	N2 R/MIN	i	M2 Nm	Fm	N	UNIT DESIGNATION Column Entry 1 Through 20 Spaces to be filled when entering order	Kg	Motor Frame Size
	Output Speed	Ratio	Output Torque	Service Factor	Overhung Load			
4 POLE	156	9.09	44	3.76	4000	M 0 3 2 2 9 . 0 _ M _ _ _ . 7 5 A - -	22.5	80A
	127	11.15	54	3.28	4000	1 1 .		
	114	12.37	60	3.07	4000	1 2 .		
	101	14.05	69	2.81	4000	1 4 .		
	89	15.97	77	2.63	3935	1 6 .		
	80	17.58	85	2.42	3844	1 8 .		
	70	20.23	99	2.11	3689	2 0 .		
	64	21.99	107	1.94	3568	2 2 .		
	54	26.4	128	1.63	3045	2 8 .		
	45	31.68	154	1.35	3182	3 2 .		

Selected unit's service factor (Fm) = 1.94, therefore unit is acceptable.

6 CHECK OVERHUNG LOADS

If sprocket, gear, etc is mounted on the outputshaft then refer to Overhung Loads Procedure, page 94, and compare with allowable overhung load (N) of selected unit

Allowable overhung load (N) must be equal or more than calculated overhung load (P)

0.75 kW	N2 R/MIN	i	M2 Nm	Fm	N	UNIT DESIGNATION Column Entry 1 Through 20 Spaces to be filled when entering order	Kg	Motor Frame Size
	Output Speed	Ratio	Output Torque	Service Factor	Overhung Load			
4 POLE	177	8	39	3.47	4000	M 0 2 2 2 8 . 0 _ M _ _ _ . 7 5 A - -	22.5	80A
	156	9.09	44	3.14	4000	9 . 0		
	127	11.15	54	2.65	4000	1 1 .		
	114	12.37	60	2.45	4000	1 2 .		
	101	14.05	68	2.22	4000	1 4 .		
	89	15.97	78	2.04	3968	1 6 .		
	80	17.58	85	1.86	3878	1 8 .		
	70	20.23	99	1.61	3757	2 0 .		
	64	21.99	107	1.48	4000	2 2 .		
	54	26.4	128	1.24	3847	2 8 .		

NOTE: If any of the following conditions occur then consult Application Engineering:-

- a) Mass acceleration factor > 10
- b) Ambient temperature is above 40°C

SERIES M

UNIT VERSIONS

UNIT VERSIONS, COLUMN 9 ENTRY

B

- Base Mounted

E

- Flange mount with B14 (C) Flange Mounting (For sizes M01 to M08 only)

Flange Mounted

Letter Entry Depends on Flange Diameter See tables below

Flange Diameter	Column 9 Entry	Flange Diameter	Column 9 Entry
120	H	300	P
140	J	350	R
160	K	450	F
200	L	550	G
250	N		

Unit Size				Flange Dia	Column 9 Entry
Double	Triple	Quadruple	Quintuple		
M0122	M0132	-	-	120	H
				140	J
				160	K
				200	L
M0222	M0232	-	-	120	H
				140	J
				160	K
				200	L
M0322	M0332	M0342	M0352	120	H
				140	J
				160	K
				200	L
M0422	M0432	M0442	M0452	140	J
				160	K
				200	L
				250	N
M0522	M0532	M0542	M0552	140	J
				160	K
				200	L
				250	N
M0622	M0632	M0642	M0652	200	L
				250	N
				300	P
M0722	M0732	M0742	M0752	200	L
				250	N
				300	P
M0822	M0832	M0842	M0852	300	P
				350	R
M0921	M0931	M0941	M0951	450	F
M1021	M1031	M1041	M1051	450	F
M1321	M1331	M1341	M1351	550	G
M1421	M1431	M1441	M1451	550	G

SERIES M

OUTPUT SHAFT OPTIONS

OUTPUTSHAFT OPTIONS

* Inch shaft has an open ended keyway, therefore no 'L11' dimension is required.

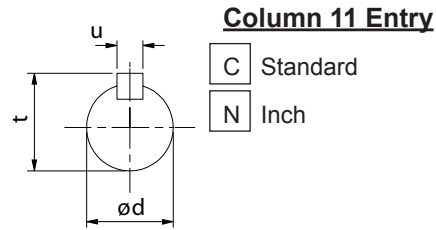
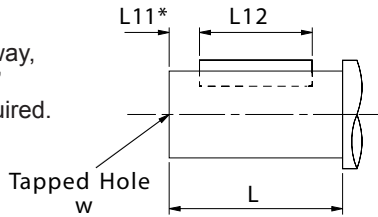

OUTPUTSHAFT OPTIONS - double, triple, quadruple and quintuple reduction

SIZE OF UNIT	TYPE OF OUTPUT SHAFT	COLUMN 11 ENTRY	DIMENSIONS IN MM (Inch Shaft in Inches)						
			ϕd	L	L11	L12	t	u	w
01	Standard	C	20.015 / 20.002	40	4	32	22.5	6	M6 x 1, 16 deep
	Inch *	N	0.7500"/0.7495"	1.575"	-	1 ⁹ / ₃₂ "	0.829"	3 ³ / ₁₆ "	1/4" UNF x 0.63" deep
02	Standard	C	25.015 / 25.002	50	4	40	28	8	M10 x 1.5, 22 deep
	Inch *	N	1.0000"/0.9995"	1.969"	-	1 ⁹ / ₁₆ "	1.106"	1/4"	1/4" UNF x 0.71" deep
03	Standard	C	25.015 / 25.002	50	4	40	28	8	M10 x 1.5, 22 deep
	Inch *	N	1.0000"/0.9995"	1.969"	-	1 ⁹ / ₁₆ "	1.106"	1/4"	1/4" UNF x 0.71" deep
04	Standard	C	30.015 / 30.002	60	4	50	33	8	M10 x 1.5, 22 deep
	Inch *	N	1.2500"/1.2495"	2.362"	-	2"	1.359"	1/4"	3/8" UNF x 0.86" deep
05	Standard	C	35.018 / 35.002	70	7	60	38	10	M12 x 1.75, 28 deep
	Inch *	N	1.3750"/1.3745"	2.756"	-	2 ³ / ₈ "	1.507"	5 ¹ / ₁₆ "	3/8" UNF x 0.75" deep
06	Standard	C	35.018 / 35.002	70	7	60	38	10	M12 x 1.75, 28 deep
	Inch *	N	1.3750"/1.3745"	2.756"	-	2 ³ / ₈ "	1.507"	5 ¹ / ₁₆ "	3/8" UNF x 0.75" deep
07	Standard	C	40.018 / 40.002	80	5	70	43	12	M16 x 2.0, 36 deep
	Inch *	N	1.6250"/1.6240"	3.150"	-	2 ³ / ₈ "	1.784"	3 ³ / ₈ "	5/8" UNF x 1.25" deep
08	Standard	C	50.018 / 50.002	100	10	80	53.5	14	M16 x 2.0, 36 deep
	Inch *	N	2.1250"/2.1240"	3.937"	-	2 ³ / ₄ "	2.338"	1/2"	3/4" UNF x 1.50" deep
09	Standard	C	60.030 / 60.011	120	10	100	64	18	M20 x 2.5, 42 deep
	Inch *	N	2.3750" / 2.3740"	4.72"	-	3 ¹ / ₁₆ "	2.65"	0.625"	3/4" UNF 1.65" deep
10	Standard	C	70.030 / 70.011	140	15	110	74.5	20	M20 x 2.5, 42 deep
	Inch *	N	2.875" / 2.874"	5.51"	-	4 ⁵ / ₈ "	3.20"	0.75"	3/4" UNF 1.65" deep
13	Standard	C	90.035 / 90.013	170	15	140	95	25	M24 x 3.0, 50 deep
	Inch *	N	3.625" / 3.624"	6.69"	-	5 ¹⁵ / ₁₆ "	4.01"	0.875"	1" UNF 1.97" deep
14	Standard	C	100.035 / 100.013	210	15	180	106	28	M24 x 3.0, 50 deep
	Inch *	N	4.000" / 3.999"	8.27"	-	7 ¹ / ₂ "	4.44"	1.00"	1" UNF 1.97" deep

SERIES M

MOTOR ADAPTERS

DOUBLE REDUCTION UNITS

IEC Flanges B14 - Column 12 Entry For Unit Types Column 10 Entries G, H and M Only

MOTOR FRAME FLANGE	UNIT SIZE, NUMBER OF REDUCTIONS, REVISION NUMBER													
	RATIO COVERAGE		M0122	M0222	M0322	M0422	M0522	M0622	M0722					
	3.6 - 9.0	11. - 56.	3.6 - 14.	16. - 56.	3.6 - 14.	16. - 56.	3.6 - 11.	12. - 56.	3.6 - 11.	12. - 56.	5.0 - 12.	14. - 63.	3.6 - 9.0	11. - 56.
71	H		H	-	H	-	H	-	-	-	-	-	-	-
80	B		K	B	K	B	K	-	G	-	G	-	G	-
90	D		R	D	R	D	R	-	J	-	J	-	J	-
100	F		S	F	S	F	S	B	L	B	L	B	L	B
112	F		S	F	S	F	S	B	L	B	L	B	L	B
132	-		-	-	-	-	-	-	-	-	-	-	D	N

■ Limited Availability / Non Preferred

IEC Flanges B5 - Column 12 Entry For Unit Types Column 10 Entries G, H and M Only

MOTOR FRAME FLANGE	UNIT SIZE, NUMBER OF REDUCTIONS, REVISION NUMBER																												
	RATIO COVERAGE		M0122	M0222	M0322	M0422	M0522	M0622	M0722	M0822	M0921	M1021	M1321	M1421															
	3.6 - 9.0	11. - 56.	3.6 - 14.	16. - 56.	3.6 - 14.	16. - 56.	3.6 - 11.	12. - 56.	3.6 - 11.	12. - 56.	5.0 - 12.	14. - 63.	3.6 - 9.0	11. - 56.	3.6 - 14.	16. - 56.	1.4 - 14.	16. - 71.	1.4 - 14.	16. - 71.	2.8 - 14.	16. - 45.	50. - 71.	2.8 - 14.	16. - 45.	50. - 71.			
63	F		F	-	F	-	F	-	V	-	V	-	V	-	-	-	-	-	-	-	-	-	-	-	-	-	-	-	
71	G		G	-	G	-	G	-	D	-	D	-	D	-	-	-	-	-	-	-	-	-	-	-	-	-	-	-	
80	A		J	A	J	A	J	W	F	W	F	W	F	F	-	D	-	E	-	-	-	-	-	-	-	-	-	-	
90	C		Q	C	Q	C	Q	Y	H	Y	H	Y	H	-	H	-	E	-	F	-	-	-	-	-	-	-	-	-	
100	-		-	-	-	-	-	A	K	A	K	A	K	A	K	A	F	-	G	-	F	-	G	N	-	S	W		
112	-		-	-	-	-	-	A	K	A	K	A	K	A	K	A	F	-	G	-	F	-	G	N	-	S	W		
132	-		-	-	-	-	-	N	P	N	P	N	P	N	P	C	M	B	G	-	H	-	F	-	H	P	-	T	X
160	-		-	-	-	-	-	-	-	-	-	-	-	-	-	E	-	C	H	A	J	A	G	A	J	Q	A	G	N
180	-		-	-	-	-	-	-	-	-	-	-	-	-	-	-	-	B	K	B	H	B	K	R	B	H	P		
200	-		-	-	-	-	-	-	-	-	-	-	-	-	-	-	-	C	-	C	-	C	L	S	C	J	Q		
225	-		-	-	-	-	-	-	-	-	-	-	-	-	-	-	-	D	-	D	-	D	M	T	D	K	R		
250	-		-	-	-	-	-	-	-	-	-	-	-	-	-	-	-	-	-	-	-	E	U	-	E	L	-		
280	-		-	-	-	-	-	-	-	-	-	-	-	-	-	-	-	-	-	-	-	F	W	-	F	M	-		

NEMA Flanges C Face - Column 12 Entry For Unit Types Column 10 Entries A, E and N Only

MOTOR FRAME FLANGE	UNIT SIZE, NUMBER OF REDUCTIONS, REVISION NUMBER																											
	RATIO COVERAGE		M0122	M0222	M0322	M0422	M0522	M0622	M0722	M0822	M0921	M1021	M1321	M1421														
	3.6 - 9.0	11. - 56.	3.6 - 14.	16. - 56.	3.6 - 14.	16. - 56.	3.6 - 11.	12. - 56.	3.6 - 11.	12. - 56.	5.0 - 12.	14. - 63.	3.6 - 9.0	11. - 56.	3.6 - 14.	16. - 56.	1.4 - 14.	16. - 71.	1.4 - 14.	16. - 71.	2.8 - 14.	16. - 45.	50. - 71.	2.8 - 14.	16. - 45.	50. - 71.		
56c	T		U	T	U	T	U	-	Q	-	Q	-	Q	-	Q	-	M	-	-	-	-	-	-	-	-	-	-	-
143/145TC	V		W	V	W	V	W	-	R	-	R	-	R	-	R	-	N	-	-	-	-	-	-	-	-	-	-	-
182/184TC	X		-	X	-	X	-	S	T	S	T	S	T	S	T	J	P	-	S	-	P	-	N	A	-	W	X	
213/215TC	-		-	-	-	-	-	U	-	U	-	U	-	U	V	K	Q	-	T	-	Q	-	P	B	-	N	A	
254/256TC	-		-	-	-	-	-	-	-	-	-	-	-	-	-	-	-	-	-	-	-	-	-	-	-	-	-	-
284/286TC	-		-	-	-	-	-	-	-	-	-	-	-	-	-	-	-	-	Q	V	M	S	G	R	D	F	Q	C
324/326TC	-		-	-	-	-	-	-	-	-	-	-	-	-	-	-	-	-	R	W	N	T	H	S	E	G	R	D
364/365TC	-		-	-	-	-	-	-	-	-	-	-	-	-	-	-	-	-	-	-	-	-	J	T	-	H	S	-
404/405TC	-		-	-	-	-	-	-	-	-	-	-	-	-	-	-	-	-	-	-	-	-	K	U	-	J	T	-

SERIES M

MOTOR ADAPTERS

TRIPLE REDUCTION UNITS

IEC Flanges B14 - Column 12 Entry For Unit Types Column 10 Entries G, H and M Only

MOTOR FRAME FLANGE	UNIT SIZE, NUMBER OF REDUCTIONS, REVISION NUMBER								
		M0132	M0232	M0332	M0432	M0532	M0632	M0732	M0832
	RATIO COVERAGE	56. - 200	56. - 200	56. - 200	56. - 200	56. - 200	63. - 25	56. - 200	56. - 200
71	COLUMN 12 ENTRY	H	H	H	H	H	-	-	
80		K	K	K	K	K	K	G	G
90		R	R	R	R	R	R	J	J
100		S	S	S	S	S	S	L	L
112		S	S	S	S	S	S	L	L
132		-	-	-	-	-	-	-	-

■ Limited Availability / Non Preferred

IEC Flanges B5 - Column 12 Entry For Unit Types Column 10 Entries G, H and M Only

MOTOR FRAME FLANGE	UNIT SIZE, NUMBER OF REDUCTIONS, REVISION NUMBER																
		M0132	M0232	M0332	M0432	M0532	M0632	M0732	M0832	M0931	M1031	M1331	M1431				
	RATIO COVERAGE	56. - 200	56. - 200	56. - 200	56. - 200	56. - 200	63. - 25	56. - 200	56. - 200	56. - 200	56. - 200	40. - 50.	56. - 160	180 - 250	40. - 50.	56. - 160	180 - 250
63	COLUMN 12 ENTRY	F	F	F	F	F	F	V	-	-	-	-	-	-	-	-	-
71		G	G	G	G	G	G	D	-	-	-	-	-	-	-	-	-
80		J	J	J	J	J	J	F	F	L	E	-	-	-	-	-	-
90		Q	Q	Q	Q	Q	Q	H	H	M	F	-	-	-	-	-	-
100		-	-	-	-	-	-	K	K	N	G	-	G	N	-	G	N
112		-	-	-	-	-	-	K	K	N	G	-	G	N	-	G	N
132		-	-	-	-	-	-	P	M	-	H	-	H	P	-	H	P
160		-	-	-	-	-	-	-	-	-	J	A	J	Q	A	J	Q
180		-	-	-	-	-	-	-	-	-	K	B	K	R	B	K	R
200		-	-	-	-	-	-	-	-	-	-	C	L	S	C	L	S
225		-	-	-	-	-	-	-	-	-	-	D	M	T	D	M	T
250		-	-	-	-	-	-	-	-	-	-	E	U	-	E	W	-
280		-	-	-	-	-	-	-	-	-	-	F	W	-	F	X	-

NEMA Flanges C Face - Column 12 Entry For Unit Types Column 10 Entries A, E and N Only

MOTOR FRAME FLANGE	UNIT SIZE, NUMBER OF REDUCTIONS, REVISION NUMBER																
		M0132	M0232	M0332	M0432	M0532	M0632	M0732	M0832	M0931	M1031	M1331	M1431				
	RATIO COVERAGE	56. - 200	56. - 200	56. - 200	56. - 200	56. - 200	63. - 25	56. - 200	56. - 200	56. - 200	56. - 200	40. - 50.	56. - 160	180 - 250	40. - 50.	56. - 160	180 - 250
56c	COLUMN 12 ENTRY	U	U	U	U	U	U	Q	Q	X	-	-	-	-	-	-	-
143/145TC		W	W	W	W	W	W	R	R	Y	-	-	-	-	-	-	-
182/184TC		-	-	-	-	-	-	T	T	Z	S	-	N	A	-	N	A
213/215TC		-	-	-	-	-	-	-	V	-	T	-	P	B	-	P	B
254/256TC		-	-	-	-	-	-	-	-	-	U	F	Q	C	F	Q	C
284/286TC		-	-	-	-	-	-	-	-	-	V	G	R	D	G	R	D
324/326TC		-	-	-	-	-	-	-	-	-	W	H	S	E	H	S	E
364/365TC		-	-	-	-	-	-	-	-	-	-	J	T	-	J	T	-
404/405TC		-	-	-	-	-	-	-	-	-	-	K	U	-	K	U	-

SERIES M

MOTOR ADAPTERS

QUADRUPLE REDUCTION UNITS

IEC Flanges B14 - Column 12 Entry For Unit Types Column 10 Entries G, H and M Only

MOTOR FRAME FLANGE	UNIT SIZE, NUMBER OF REDUCTIONS, REVISION NUMBER										
	RATIO COVERAGE	M0342	M0442	M0542	M0642	M0742	M0842	M0941	M1041	M1341	M1441
71	COLUMN 12 ENTRY	H	H	H	H	H	-	-	-	-	-
80		K	K	K	K	K	G	G	G	G	G
90		R	R	R	R	R	J	J	J	J	J
100		-	-	-	-	-	L	L	L	L	L
112		-	-	-	-	-	L	L	L	L	L
132		-	-	-	-	-	-	-	N	N	N

IEC Flanges B5 - Column 12 Entry For Unit Types Column 10 Entries G, H and M Only

MOTOR FRAME FLANGE	UNIT SIZE, NUMBER OF REDUCTIONS, REVISION NUMBER										
	RATIO COVERAGE	M0342	M0442	M0542	M0642	M0742	M0842	M0941	M1041	M1341	M1441
63	COLUMN 12 ENTRY	F	F	F	F	F	V	V	-	-	-
71		G	G	G	G	G	D	D	-	-	-
80		J	J	J	J	J	F	F	F	F	F
90		Q	Q	Q	Q	Q	H	H	H	H	H
100		-	-	-	-	-	K	K	K	K	K
112		-	-	-	-	-	K	K	K	K	K
132	-	-	-	-	-	P	P	M	M	M	

 Limited Availability / Non Preferred

NEMA Flanges C Face - Column 12 Entry For Unit Types Column 10 Entries A, E and N Only

MOTOR FRAME FLANGE	UNIT SIZE, NUMBER OF REDUCTIONS, REVISION NUMBER										
	RATIO COVERAGE	M0342	M0442	M0542	M0642	M0742	M0842	M0941	M1041	M1341	M1441
56c	COLUMN 12 ENTRY	U	U	U	U	U	Q	Q	Q	Q	Q
143/145TC		W	W	W	W	W	R	R	R	R	R
182/184TC		-	-	-	-	-	T	T	T	T	T
213/215TC		-	-	-	-	-	-	-	V	V	V

SERIES M

MOTOR ADAPTERS

QUINTUPLE REDUCTION UNITS

IEC Flanges B14 - Column 12 Entry For Unit Types Column 10 Entries G, H and M Only

MOTOR FRAME FLANGE	UNIT SIZE, NUMBER OF REDUCTIONS, REVISION NUMBER										
	RATIO COVERAGE	M0352	M0452	M0552	M0652	M0752	M0852	M0951	M1051	M1351	M1451
71	COLUMN 12 ENTRY	H	H	H	H	H	H	H	-	-	-
80		K	K	K	K	K	K	K	G	G	G
90		R	R	R	R	R	R	R	J	J	J

IEC Flanges B5 - Column 12 Entry For Unit Types Column 10 Entries G, H and M Only

MOTOR FRAME FLANGE	UNIT SIZE, NUMBER OF REDUCTIONS, REVISION NUMBER										
	RATIO COVERAGE	M0352	M0452	M0552	M0652	M0752	M0852	M0951	M1051	M1351	M1451
63	COLUMN 12 ENTRY	F	F	F	F	F	F	F	-	-	-
71		G	G	G	G	G	G	G	-	-	-
80		J	J	J	J	J	J	J	F	F	F
90		Q	Q	Q	Q	Q	Q	Q	H	H	H
100		-	-	-	-	-	-	-	K	K	K
112		-	-	-	-	-	-	-	K	K	K

 Limited Availability / Non Preferred

NEMA Flanges C Face - Column 12 Entry For Unit Types Column 10 Entries A, E and N Only

MOTOR FRAME FLANGE	UNIT SIZE, NUMBER OF REDUCTIONS, REVISION NUMBER										
	RATIO COVERAGE	M0352	M0452	M0552	M0652	M0752	M0852	M0951	M1051	M1351	M1451
56c	COLUMN 12 ENTRY	U	U	U	U	U	U	U	Q	Q	Q
143/145TC		W	W	W	W	W	W	W	R	R	R
182/184TC		-	-	-	-	-	-	-	-	T	T

SERIES M

LUBRICATION

M01,M02,M03,M04,M05,M06,& M07 Units, are supplied factory filled with EP mineral oil (Grade 6E) appropriate to the intended mounting position. If the unit is supplied without lubricant the unit must be filled with the correct lubricant and quantity as listed below.

M08,M09,M10,M13,& M14 Units, require filling with EP mineral oil (Grade 6E)
Lubricant quantities are approximate fill until oil escapes from the level plug hole, fit ventilator plug (when supplied) in the appropriate position for the required mounting position. If the unit is supplied without lubricant the unit must be filled with the correct lubricant and quantity.

LUBRICATION CHANGE PERIOD

- Sizes 02, 03, 04 and 05 are filled for life.
- All other sizes of Series M will require an oil change:
 - 10,000 hours for mineral oil
 - 20,000 hours for synthetic oil

TEMPERATURE LIMITATIONS

The standard lubricant is suitable for operation in ambient temperatures of 0° to 35°C, outside of this consult Table 1 or Application Engineers.

TABLE 1 OIL GRADES

LUBRICANT	AMBIENT TEMPERATURE RANGE		
	5°C to 20°C (type E) 30°C to 20°C (type H)	0°C to 35°C	20°C to 50°C
EP Mineral Oil (type E)	5E (VG 220)	6E (VG 320)	7E (VG 460)
Polyalphaolefin based Synthetic (type H)	5H (VG 220)	5H (VG 220)	6H (VG 320)

TABLE 2 Lubrication Quantity (Litres)

DOUBLE REDUCTION & FINAL STAGE QUADRUPLE OR QUINTUPLE REDUCTION													
Unit Size		M0122	M0222	M0322	M0422	M0522	M0622	M0722	M0822	M0921	M1021	M1321	M1421
MOUNTING POSITION	1	0.5	0.8	0.8	1.5	1.5	2.0	2.6	4.2	10.5	14.0	17.0	24.0
	2	0.8	1.2	1.2	1.8	1.8	2.0	2.9	6.3	12.0	22.0	31.0	49.0
	3	0.6	0.7	0.7	1.6	1.6	1.9	2.7	5.4	12.0	22.0	31.0	49.0
	4	0.8	1.2	1.2	1.8	1.8	1.7	3.0	7.3	12.0	19.0	28.0	41.0
	5	0.7	1.1	1.1	2.0	2.0	2.2	3.2	6.8	16.8	32.0	47.0	72.0
	6	1.0	1.4	1.4	2.6	2.6	2.8	4.7	9.3	16.4	26.0	38.0	65.0

Unit Size		M0132	M0232	M0332	M0432	M0532	M0632	M0732	M0832	M0931	M1031	M1331	M1431
MOUNTING POSITION	1	0.6	0.8	0.8	1.6	1.6	2.1	2.7	4.4	11.5	15.0	18.0	24.5
	2	0.9	1.3	1.3	1.9	1.9	2.1	3.0	6.5	12.0	24.0	33.0	50.0
	3	0.7	0.7	0.7	1.7	1.7	2.0	2.8	5.6	12.0	24.0	33.0	50.0
	4	0.9	1.2	1.2	1.9	1.9	1.8	3.1	7.5	12.0	21.0	30.0	43.0
	5	0.7	1.1	1.1	2.1	2.1	2.3	3.3	6.8	16.8	32.0	47.0	72.0
	6	1.1	1.6	1.6	2.7	2.7	2.9	4.8	9.7	16.5	28.0	40.0	67.0

PRIMARY STAGE QUADRUPLE REDUCTION (Quantities obtained from above double and triple sizes indicated)										
Unit Size	M0342	M0442	M0542	M0642	M0742	M0842	M0941	M1041	M1341	M1441
PRIMARY UNIT	M0122	M0322	M0322	M0322	M0322	M0522	M0522	M0722	M0722	M0722
SECONDARY UNIT	M0322	M0422	M0522	M0622	M0722	M0822	M0921	M1021	M1321	M1421

PRIMARY STAGE QUINTUPLE REDUCTION (Quantities obtained from above double and triple sizes indicated)										
Unit Size	M0352	M0452	M0552	M0652	M0752	M0852	M0951	M1051	M1351	M1451
PRIMARY UNIT	M0132	M0332	M0332	M0332	M0332	M0532	M0532	M0732	M0732	M0732
SECONDARY UNIT	M0322	M0422	M0522	M0622	M0722	M0822	M0921	M1021	M1321	M1421

* NOTE: Primary units filled with Grade 6E lubricant suitable for all ambient temperatures between 0°C and 35°C

SERIES M

MOUNTING POSITIONS

COLUMN 13 ENTRY

Enter for units with no oil fill

Base Mounted Units

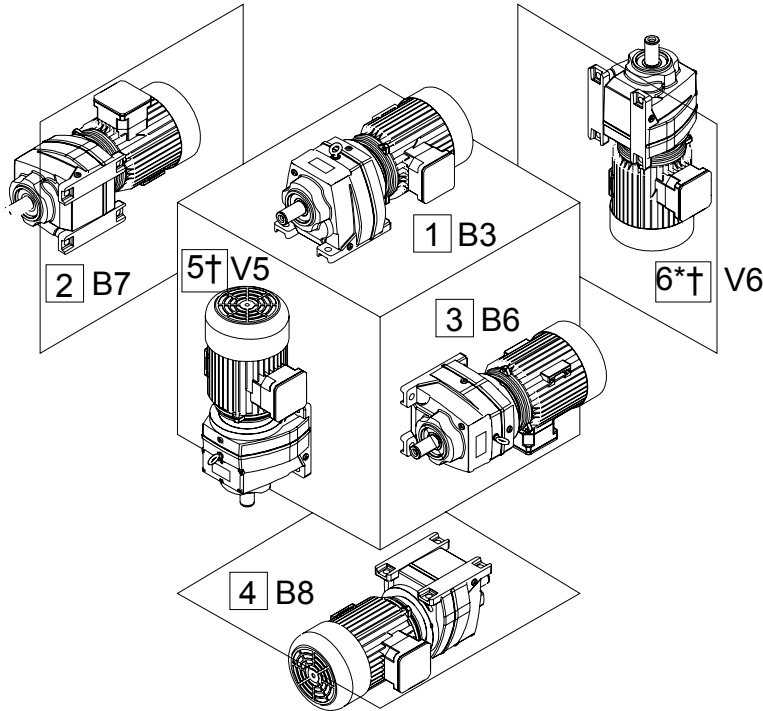

Flange Mounted Units

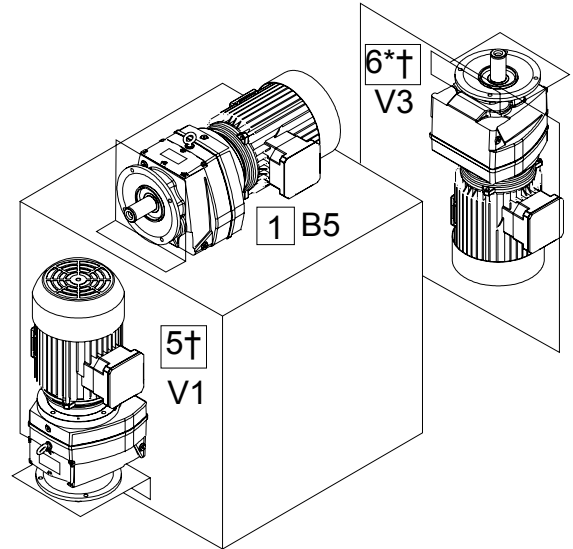

* Mounting Position 6 is not recommended for Geared Motors - Consult Application Engineering
 † Gear Units selected for use in mounting positions 5 and 6 should only be used with overall ratios greater or equal to those shown in the table below

Unit Size	Input Speed (rpm)			
	< 1000	< 1500	< 1800	> 1800
M01 - M08	All	All	All	Consult Application Engineering
M09	2.0	4.0	4.5	
M10	4.0	8.0	9.0	
M13	6.3	11.0	14.0	
M14	12.0	18.0	22.0	

MOUNTING POSITIONS - SHOWN AS MOTORISED - APPLIES ALSO FOR REDUCERS

COLUMN 14 ENTRY

ALL MOTORS

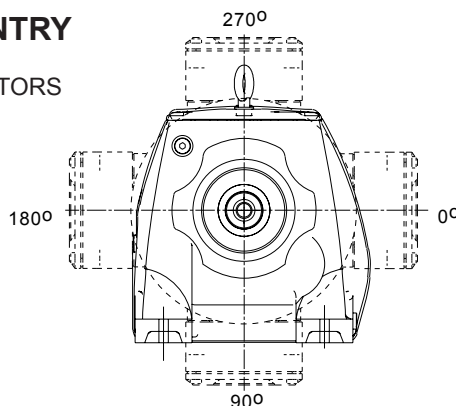

Column 14 Entry	Terminal Box Position
A	0°
B	90°
C	180°
D	270°
-	Reducer or no motor fitted

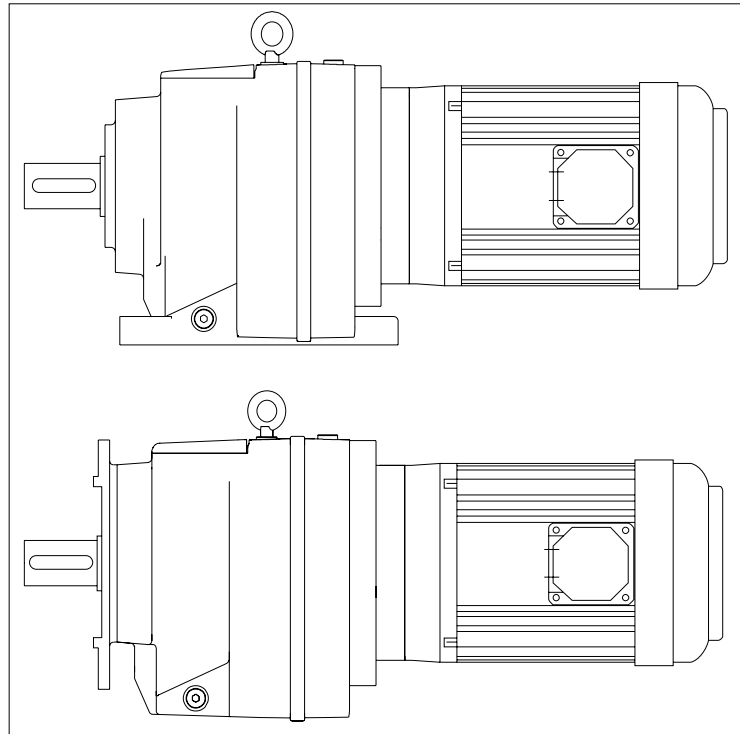

**MOTORISED
SERIES M**

SERIES M MOTOR PERFORMANCE DATA

TEFC squirrel cage three phase motors
4 poles = 1500 rpm 400V, 50Hz, S1 IP55, Class F

Output Power Kw	Frame Size	Speed (RPM)	I (A)	Ist	Tst	J (Kgm2)
				I	T	
0.12	63	1360	0.6	2.6	2.5	0.000
0.18	63	1370	0.72	3	2.2	0.000
0.25	71	1400	0.83	3.5	2.2	0.001
0.37	71	1410	1.12	4	2.2	0.001
0.55	80A	1420	1.45	4	2.2	0.002
0.75	80A	1420	2.9	4.5	2.2	0.002
1.1	90S	1410	2.59	5	2.2	0.003
1.5	90L	1420	3.45	5	2.4	0.004
2.2	100L	1430	4.8	5.5	2.4	0.007
3	100L	1430	6.48	5.5	2.5	0.008
4	100L	1420	8.73	5.5	2.5	0.009
4	112M	1435	8.6	7	2.9	0.015
5.5	112M	1425	11.4	7.1	2.8	0.018
5.5	132S	1450	11.1	7.3	2.2	0.031
7.5	132M	1450	14.8	7.9	2.5	0.038
9	132M	1450	18	8.1	2.8	0.043
11	132M	1450	21	8.3	3	0.048
11	160M	1460	21.5	6.7	2.9	0.067
15	160L	1455	28.5	6.8	2	0.091
18.5	160L	1450	36	6.9	2.9	0.102
18.5	180M	1470	35	6.7	3.1	0.161
22	180L	1470	41	6.8	2.9	0.191
30	180L	1465	56	6.9	3.2	0.225
30	200L	1475	56	6.7	2.6	0.29
37	200L	1475	68	7.8	3.6	0.34
37	225S	1480	68	6.6	2.4	0.37
45	225M	1480	83	6.7	2.7	0.42
55	225M	1480	100	7.3	3.1	0.49
55	250M	1480	98	7.5	2.3	0.72
75	250M	1480	132	7	2.4	0.88
75	280S	1483	137	6.8	2.4	1.15
90	280M	1484	163	7.1	2.7	1.4
110	280M	1483	195	7.5	2.7	1.7

High Power Motor (Non Standard)

I = Nominal current
Ist/I = Starting current factor
Tst/T = Starting torque factor
J = Motor moment of inertia

Recalculation Factors

Recalculation factors for current at rated voltages other than 400V, 50 Hz.

Rated voltage at 50Hz and motor wound for	Recalculation factor
220V	1.82
230V	1.74
415V	0,96
500V	0,80
660V	0,61
690V	0,58

TEFC squirrel cage three phase motors
6 poles = 1000 rpm 400V, 50Hz, S1 IP55, Class F

Output Power Kw	Frame Size	Speed (RPM)	I (A)	Ist	Tst	J (Kgm2)
				I	T	
0.12	63	900	0.6	2.1	2.1	0.000
0.18	71	920	0.75	2.5	2	0.001
0.25	71	920	0.92	3	2	0.001
0.37	80A	920	1.25	3.5	2.1	0.002
0.55	80B	930	1.78	3.5	2.1	0.002
0.75	90S	930	2.36	4	1.9	0.003
1.1	90L	930	3.25	4	1.9	0.004
1.5	100L	940	5.8	4.5	1.9	0.009
2.2	112M	940	5.8	4.5	1.9	0.009
2.2	100L	940	5.4	5.6	2.1	0.015
3	112M	935	7.2	5.5	2.4	0.018
3	132S	960	6.9	6.1	2.4	0.031
4	132M	960	8.7	7.1	2.6	0.038
5.5	132M	955	11.9	6.9	2.8	0.045
7.5	160M	970	15.4	6.7	2	0.089
11	160L	970	23	7.1	2.2	0.107
15	180L	970	31	7	2.1	0.217
18.5	180L	965	37.5	6.2	2	0.237
18.5	200L	985	36	7	2.5	0.370
22	200L	980	43	7.2	2.5	0.430
30	200L	980	56	7.5	3.3	0.490
30	225M	985	56	6.6	2.5	0.640
37	225S	985	69	7.7	3.1	0.750
37	250M	985	69	7.3	2.8	1.160
45	250S	985	82	7.3	2.8	1.490
45	280S	990	85	6.6	2.6	1.650

High Power Motor (Non Standard)

I = Nominal current
Ist/I = Starting current factor
Tst/T = Starting torque factor
J = Motor moment of inertia

60 Hz Operation

Motors wound for a certain voltage at 50 Hz can be operated at 60 Hz, without any modifications, subject to the following changes in their data

Motor wound for 50 Hz and	Connected to 60 Hz and	Data at 60 Hz in percentage of values at 50 Hz					
		P kW	n rpm	I A	Ist/I	T Nm	Tst/T
400V	380V	100	120	100	80	83	66
	400V	100	120	98	83	83	70
	415V	105	120	100	88	86	78
	440V	110	120	100	95	91	85
	460V	115	120	100	100	96	95
	480V	120	120	100	105	100	100

SERIES M

MOTOR DETAILS

B14 'C' FACE

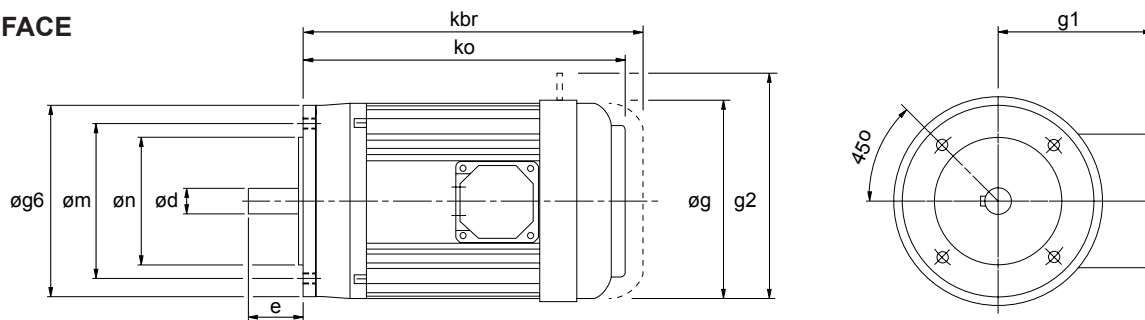

MOTOR FRAME SIZE	Øg6	Øm	Øn	Ød	e	ko*	kbr*	Øg	g1*	m	Øs
71	105	85	70	14	30	221	265	138	102	45°	4 x M6
80A	120	100	80	19	40	239	291	157	125	45°	4 x M6
80B	120	100	80	19	40	248	300	157	125	45°	4 x M6
90S	140	115	95	24	50	260	312	177	133	45°	4 x M8
90L	140	115	95	24	50	275	327	177	133	45°	4 x M8
100L	160	130	110	28	60	310	370	197	144	45°	4 x M8
112M	160	130	110	28	60	325	399	219	155	45°	4 x M8
132S	200	165	130	38	80	392	475	235	172	45°	4 x M10
132M	200	165	130	38	80	412	495	235	172	45°	4 x M10

B5 'D' FACE

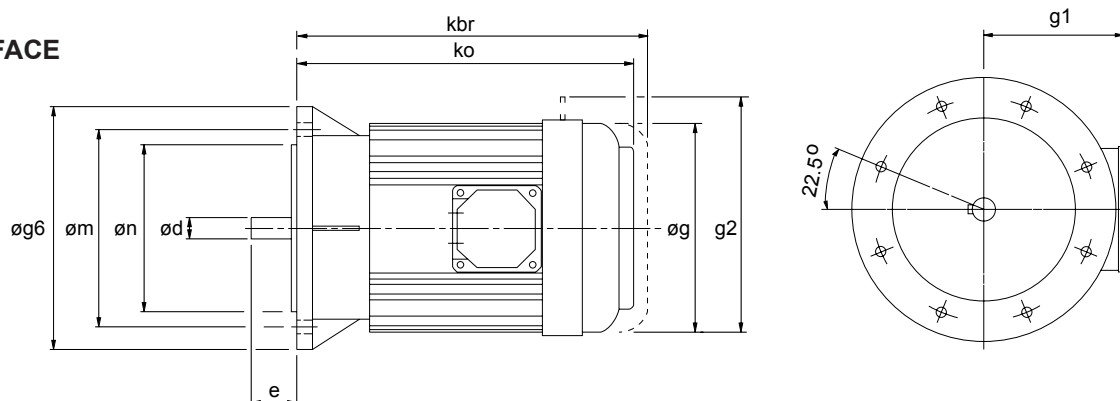

MOTOR FRAME SIZE	Øg6	Øm	Øn	Ød	e	ko*	kbr*	Øg	g1*	m	Øs
63	140	115	95	11	23	218	263	122	96	45°	4 x M8
71	160	130	110	14	30	221	265	138	102	45°	4 x M8
80A	200	165	130	19	40	239	291	157	125	45°	4 x M10
80B	200	165	130	19	40	248	300	157	125	45°	4 x M10
90S	200	165	130	24	50	260	312	177	133	45°	4 x M10
90L	200	165	130	24	50	275	327	177	133	45°	4 x M10
100L	250	215	180	28	60	310	370	197	144	45°	4 x M12
112M	250	215	180	28	60	325	399	219	155	45°	4 x M12
132S	300	265	230	38	80	392	475	235	172	45°	4 x M12
132M	300	265	230	38	80	412	495	235	172	45°	4 x M12
160M	350	300	250	42	110	455	538	273	282	45°	4 x M16
160L	350	300	250	42	110	500	583	273	282	45°	4 x M16
180M	350	300	250	48	110	557	-	382	307	22.5°	4 x M16
180L	350	300	250	48	110	595	-	382	307	22.5°	4 x M16
200L	400	350	300	55	110	658	-	420	372	-	4 x M16
225S	450	400	350	60	140	671	-	458	427	-	8 x M16
225M	450	400	350	60	140	696	-	458	427	-	8 x M16
250M	550	500	450	65	140	771	-	510	490	-	8 x M16
280S	550	500	450	75	140	837	-	576	520	-	8 x M16
280M	550	500	450	75	140	888	-	576	520	-	8 x M16

* Motor lengths for own brand standard motors. These lengths may vary if alternative motor is fitted.

SERIES M

ADDITIONAL MOTOR FEATURES

ADDITIONAL MOTOR FEATURES - COLUMN 19 ENTRY

Column 19 Entry	Brake Motor	Hand Release on Brake	Forced Ventilation/ Constant Blower (TECB)	Thermistors	Special
-					
A	•				
B	•	•			
C			•		
D	•		•		
E	•	•	•		
F				•	
G	•			•	
H	•	•		•	
K			•	•	
L	•		•	•	
M	•	•	•	•	
S					•

Please refer to Application Engineering for details of the following additional motor features

- PGF encoder flange
- Wash down
- Customised brake torque
- Separate brake supply
- Aluminium fan
- Anti Condensation heater
- Bi-metal temperature detectors, Thermostat
- EExEIIT3
- Ex nA II T3
- IP56
- IP65
- Metal fan cover
- Rain cowl
- Separate terminal box

SERIES M

ADDITIONAL GEARBOX FEATURES

ADDITIONAL GEARBOX FEATURES - COLUMN 20 ENTRY

Column 20 Entry	Double Outputshaft Oil Seals	Oil Level Glass M07 - M14	* Motorised Backstop		Special
			CW Rotation	CCW Rotation	
-					
A	•				
B		•			
C	•	•			
D			•		
E	•		•		
F		•	•		
G	•	•	•		
H				•	
I	•			•	
J		•		•	
K	•	•		•	
L					•

Please refer to Application Engineering for details of the following additional gearbox features

- Prime paint only
- Wash down
- BISSC compatible
- Special oil (food compatible, bio-degradable, different viscosities etc)

* IEC frame sizes 100 - 200 NEMA frame sizes 182TC - 326TC see page 92 for details.

SERIES M

SELECTION TABLES

GEARED MOTORS

0.12 kW

4 POLE

N2 R/MIN	i	M2 Nm	Fm	N	Unit Designation	Kg	Motor Size
Output Speed	Ratio	Output Torque	Service Factor	Overhung Load	Column Entry [1] Through [20] Spaces to be filled when entering order	Weight	
363	3.75	3	19.46	1690	M 0 1 2 2 3 . 6 _ M _ _ _ _ . 1 2 A - -	13.5	63
268	5.07	4	16.34	1790	5 . 0		
236	5.76	4	15.24	1840	5 . 6		
208	6.53	5	14.07	1880	6 . 3		
163	8.35	6	11.65	1900	8 . 0		
151	9	7	10.94	1900	9 . 0		
120	11.36	9	9.07	1900	1 1 .		
106	12.88	10	8.29	1900	1 2 .		
92	14.71	11	7.48	1900	1 4 .		
83	16.37	13	6.75	1900	1 6 .		
75	18.05	14	6.11	1900	1 8 .		
68	19.86	16	5.56	1900	2 0 .		
58	23.27	18	4.74	1900	2 2 .		
49	27.92	22	3.96	1900	2 8 .		
42	32.54	26	3.41	1900	3 2 .		
38	36.16	29	3.07	1900	3 6 .		
31	43.54	35	2.38	1900	4 5 .		
27	49.91	40	1.78	1900	5 0 .		
24	56.72	45	1.54	1900	5 6 .		
23	58.46	46	1.93	1900	M 0 1 3 2 5 6 . _ M _ _ _ _ . 1 2 A - -	14.5	63
21	64.45	51	1.75	1900	6 3 .		
19	70.93	56	1.59	1900	7 1 .		
16	83.1	66	1.36	1900	8 0 .		
14	99.7	79	1.13	1830	1 0 0		
12	116.22	92	0.97	1650	1 1 2		
11	129.13	102	0.88	1360	1 2 5		
25	53.54	43	3.69	4000	M 0 2 2 2 5 6 . _ M _ _ _ _ . 1 2 A - -	16.5	63
24	57.03	45	3.5	4000	M 0 2 3 2 5 6 . _ M _ _ _ _ . 1 2 A - -	17.5	63
22	62.87	50	3.17	4000	6 3 .		
20	69.19	55	2.88	4000	7 1 .		
17	81.07	64	2.46	4000	8 0 .		
14	97.26	77	2.06	4000	1 0 0		
12	113.37	90	1.77	4000	1 1 2		
11	125.97	100	1.59	4000	1 2 5		
9	151.69	121	1.32	4000	1 6 0		
7.8	173.87	139	1.15	4000	1 8 0		
6.9	197.6	157	1.02	4000	2 0 0		
20	69.19	55	3.77	4000	M 0 3 3 2 7 1 . _ M _ _ _ _ . 1 2 A - -	17.5	63
17	81.07	64	3.22	4000	8 0 .		
14	97.26	77	2.69	4000	1 0 0		
12	113.37	90	2.31	4000	1 1 2		
11	125.97	100	2.08	4000	1 2 5		
9	151.69	121	1.72	4000	1 6 0		
7.8	173.87	138	1.51	4000	1 8 0		
6.9	197.6	157	1.33	4000	2 0 0		
5.8	234.96	182	1.15	3026	M 0 3 4 2 2 2 5 _ M _ _ _ _ . 1 2 A - -	26.5	63
5.2	261.37	202	1.03	3026	2 5 0		
4.7	287.83	222	0.94	3026	2 8 0		
4.3	317.33	245	0.85	3026	3 0 0		
12	115.82	92	3.64	7200	M 0 4 3 2 1 1 2 _ M _ _ _ _ . 1 2 A - -	26.5	63
10	130.5	104	3.24	7200	1 2 5		
9	151.71	121	2.78	7200	1 6 0		
7.9	172.19	137	2.45	7200	1 8 0		
6.9	195.75	156	2.16	7200	2 0 0		
9	151.71	121	3.7	7200	M 0 5 3 2 1 6 0 _ M _ _ _ _ . 1 2 A - -	27.5	63
7.9	172.19	138	3.26	7200	1 8 0		
6.9	195.75	156	2.87	7200	2 0 0		
6.4	213.18	171	3.66	7200	M 0 6 3 2 2 0 0 _ M _ _ _ . 1 2 A - -	32.5	63

NOTE
Other output speeds are available using 2 and 8 pole motors - Consult Application Engineering

SERIES M

SELECTION TABLES

GEARED MOTORS

0.12 kW

6 POLE

N2 R/MIN	i	M2 Nm	Fm	N	Unit Designation	Kg	Motor Size
Output Speed	Ratio	Output Torque	Service Factor	Overhung Load	Column Entry <input type="text" value="1"/> Through <input type="text" value="20"/> Spaces to be filled when entering order	Weight	
232	3.75	4	14.27	1810	M 0 1 2 2 3 . 6 _ M _ _ _ _ . 1 2 C - -	13.5	63
172	5.07	6	11.71	1900	5 . 0		
151	5.76	7	10.65	1900	5 . 6		
133	6.53	8	9.59	1900	6 . 3		
104	8.35	10	8.01	1900	8 . 0		
97	9	11	7.54	1900	9 . 0		
77	11.36	14	6.19	1900	1 1 .		
68	12.88	16	5.47	1900	1 2 .		
59	14.71	18	4.79	1900	1 4 .		
53	16.37	20	4.31	1900	1 6 .		
48	18.05	22	3.9	1900	1 8 .		
44	19.86	25	3.55	1900	2 0 .		
37	23.27	29	3.04	1900	2 2 .		
31	27.92	35	2.54	1900	2 8 .		
27	32.54	41	2.17	1900	3 2 .		
24	36.16	45	1.96	1900	3 6 .		
20	43.54	55	1.52	1900	4 5 .		
17	49.91	63	1.14	1900	5 0 .		
15	56.72	71	0.99	1900	5 6 .		
15	58.46	72	1.23	1900	M 0 1 3 2 5 6 . _ M _ _ _ _ . 1 2 C - -	14.5	63
13	64.45	80	1.12	1900	6 3 .		
12	70.93	88	1.01	1900	7 1 .		
10	83.1	103	0.87	1360	8 0 .		
21	41.49	52	3.04	4000	M 0 2 2 2 4 5 . _ M _ _ _ _ . 1 2 C - -	16.5	63
18	47.09	59	2.68	4000	5 0 .		
16	53.54	67	2.36	4000	5 6 .		
15	57.03	71	2.24	4000	M 0 2 3 2 5 6 . _ M _ _ _ _ . 1 2 C - -	17.5	63
14	62.87	79	2.02	4000	6 3 .		
13	69.19	86	1.84	4000	7 1 .		
11	81.07	101	1.57	4000	8 0 .		
8.9	97.26	121	1.31	4000	1 0 0		
7.7	113.37	142	1.13	4000	1 1 2		
6.9	125.97	156	1.02	4000	1 2 5		
5.7	151.69	189	0.85	3200	1 6 0		
13	69.19	86	2.41	4000	M 0 3 3 2 7 1 . _ M _ _ _ _ . 1 2 C - -	17.5	63
11	81.07	101	2.05	4000	8 0 .		
8.9	97.26	121	1.71	4000	1 0 0		
7.7	113.37	141	1.47	4000	1 1 2		
6.9	125.97	157	1.33	4000	1 2 5		
5.7	151.69	189	1.1	3500	1 6 0		
5	173.87	217	0.96	3000	1 8 0		
4.4	197.6	247	0.85	2400	2 0 0		
7.5	115.82	145	2.33	7200	M 0 4 3 2 1 1 2 _ M _ _ _ _ . 1 2 C - -	26.5	63
6.7	130.5	163	2.07	7200	1 2 5		
5.7	151.71	190	1.77	7200	1 6 0		
5.1	172.19	215	1.57	7200	1 8 0		
4.4	195.75	244	1.38	7200	2 0 0		
5.7	151.71	190	2.36	7200	M 0 5 3 2 1 6 0 _ M _ _ _ _ . 1 2 C - -	27.5	63
5.1	172.19	215	2.08	7200	1 8 0		
4.4	195.75	245	1.84	7200	2 0 0		
4.1	213.18	267	2.34	7200	M 0 6 3 2 2 0 0 _ M _ _ _ _ . 1 2 C - -	32.5	63

NOTE

Other output speeds are available using 2 and 8 pole motors - Consult Application Engineering

SERIES M

SELECTION TABLES

GEARED MOTORS

0.18 kW

4 POLE

N2 R/MIN	i	M2 Nm	Fm	N	Unit Designation	Kg	Motor Size
Output Speed	Ratio	Output Torque	Service Factor	Overhung Load	Column Entry [1] Through [20] Spaces to be filled when entering order	Weight	
365	3.75	4	13.07	1681	M 0 1 2 2 3 . 6 - M - - - - - . 1 8 A - -	13.5	63
270	5.07	6	10.97	1778	5 . 0		
238	5.76	6	10.24	1826	5 . 6		
210	6.53	7	9.45	1856	6 . 3		
164	8.35	10	7.82	1873	8 . 0		
152	9	10	7.35	1872	9 . 0		
121	11.36	13	6.09	1874	1 1 .		
106	12.88	15	5.56	1874	1 2 .		
93	14.71	17	5.02	1854	1 4 .		
84	16.37	19	4.53	1890	1 6 .		
76	18.05	21	4.1	1877	1 8 .		
69	19.86	24	3.73	1852	2 0 .		
59	23.27	28	3.19	1881	2 2 .		
49	27.92	33	2.66	1819	2 8 .		
42	32.54	39	2.29	1878	3 2 .		
38	36.16	43	2.06	1854	3 6 .		
31	43.54	52	1.6	1890	4 5 .		
27	49.91	60	1.2	1849	5 0 .		
24	56.72	68	1.03	1900	5 6 .		
23	58.46	69	1.3	1724	M 0 1 3 2 5 6 . - M - - - - - . 1 8 A - -	14.5	63
21	64.45	76	1.18	1590	6 3 .		
19	70.93	84	1.07	1780	7 1 .		
16	83.1	98	0.91	1450	8 0 .		
38	35.69	43	3.72	4000	M 0 2 2 2 3 6 . - M - - - - - . 1 8 A - -	16.5	63
33	41.49	50	3.19	4000	4 5 .		
29	47.09	56	2.81	4000	5 0 .		
26	53.54	64	2.48	3956	5 6 .		
24	57.03	68	2.35	4000	M 0 2 3 2 5 6 . - M - - - - - . 1 8 A - -	17.5	63
22	62.87	75	2.13	4000	6 3 .		
20	69.19	82	1.94	4000	7 1 .		
17	81.07	96	1.65	3913	8 0 .		
14	97.26	115	1.38	4000	1 0 0		
12	113.37	134	1.19	3976	1 1 2		
11	125.97	149	1.07	4000	1 2 5		
9	151.69	180	0.89	4000	1 6 0		
33	41.49	50	3.96	4000	M 0 3 2 2 4 5 . - M - - - - - . 1 8 A - -	16.5	63
29	47.09	56	3.57	4000	5 0 .		
26	53.54	64	3.19	4000	5 6 .		
24	57.03	68	3.07	4000	M 0 3 3 2 5 6 . - M - - - - - . 1 8 A - -	17.5	63
22	62.87	75	2.78	4000	6 3 .		
20	69.19	82	2.53	3743	7 1 .		
17	81.07	96	2.16	3913	8 0 .		
14	97.26	115	1.81	3654	1 0 0		
12	113.37	134	1.55	3976	1 1 2		
11	125.97	149	1.4	3718	1 2 5		
9	151.69	180	1.15	3173	1 6 0		
7.9	173.87	206	1.01	3420	1 8 0		
6.9	197.6	234	0.89	2660	2 0 0		
19	73.95	88	3.82	7200	M 0 4 3 2 7 1 . - M - - - - - . 1 8 A - -	26.5	63
17	80.4	96	3.51	7200	8 0 .		
14	96.52	115	2.93	7200	1 0 0		
12	115.82	138	2.45	7102	1 1 2		
10	130.5	155	2.17	7200	1 2 5		
9	151.71	180	1.87	7178	1 6 0		
8	172.19	205	1.65	7034	1 8 0		
7	195.75	233	1.45	7200	2 0 0		
5.9	232.81	269	1.25	7125	M 0 4 4 2 2 2 5 . - M - - - - - . 1 8 A - -	38.5	63
5.3	260.47	300	1.12	7125	2 5 0		
4.9	277.62	320	1.06	7125	2 8 0		
4.5	305.72	353	0.96	7125	3 0 0		
3.8	362.32	416	0.81	7125	3 6 0		
14	96.52	115	3.89	7200	M 0 5 3 2 1 0 0 . - M - - - - - . 1 8 A - -	27.5	63
12	115.82	138	3.25	7200	1 1 2		
10	130.5	155	2.89	7200	1 2 5		
9	151.71	181	2.48	6660	1 6 0		
8	172.19	205	2.19	6902	1 8 0		
7	195.75	233	1.93	6628	2 0 0		
5.9	232.81	271	1.66	4809	M 0 5 4 2 2 2 5 . - M - - - - - . 1 8 A - -	40.5	63
5.3	260.47	302	1.49	4809	2 5 0		
4.9	277.62	322	1.4	4809	2 8 0		
4.5	305.72	355	1.27	4809	3 0 0		
3.8	362.32	419	1.07	4809	3 6 0		
3.3	416.75	482	0.93	4809	4 0 0		
3.1	444.96	514	0.87	4809	4 5 0		
2.8	483.76	559	0.8	4809	5 0 0		
8.5	161.57	192	3.24	7200	M 0 6 3 2 1 6 0 . - M - - - - - . 1 8 A - -	32.5	63
7.3	187.83	224	2.79	7200	1 8 0		
6.4	213.18	254	2.46	7200	2 0 0		
6.4	215.23	252	2.48	7200	M 0 6 4 2 2 2 5 . - M - - - - - . 1 8 A - -	45.5	63
5.8	237.02	278	2.25	7200	2 5 0		
5	272.91	318	1.66	7200	2 8 0		
4.4	313.91	366	1.44	7200	3 0 0		
3.8	365.1	426	1.4	7200	3 6 0		
3.5	396.93	463	1.29	7200	4 0 0		
3.1	444.1	516	1.21	7200	4 5 0		
2.6	533.13	620	1.01	7200	5 0 0		
2.4	568.23	661	0.95	7200	6 5 0		
6	229	268	3.24	4677	M 0 7 4 2 2 2 5 . - M - - - - - . 1 8 A - -	52.5	63
5.3	259.68	303	2.86	4676	2 5 0		
4.8	286.42	334	2.59	4676	2 8 0		
4.3	315.41	368	2.35	4676	3 0 0		
3.8	361.21	421	2.06	4675	3 6 0		
3.3	415.49	484	1.79	4675	4 0 0		
2.9	469.77	546	1.59	4675	4 5 0		
2.7	510.72	594	1.46	4675	5 0 0		
2.3	592.12	687	1.28	4675	6 5 0		
1.9	710.84	824	1.05	4675	7 3 0		
1.6	847.84	979	0.89	4674	8 6 0		

NOTE
Other output speeds are available using 2 and 8 pole motors - Consult Application Engineering

SERIES M

SELECTION TABLES

GEARED MOTORS

0.18 kW

6 POLE

N2 R/MIN	i	M2 Nm	Fm	N	Unit Designation	Kg	Motor Size
Output Speed	Ratio	Output Torque	Service Factor	Overhung Load	Column Entry [1] Through [20] Spaces to be filled when entering order	Weight	
240	3.75	6	9.84	1791	M 0 1 2 2 3 . 6 _ M _ _ _ _ . 1 8 C - -	14.5	71
178	5.07	9	8.07	1874	5 . 0		
156	5.76	10	7.34	1874	5 . 6		
138	6.53	12	6.61	1874	6 . 3		
108	8.35	15	5.52	1874	8 . 0		
100	9	16	5.2	1868	9 . 0		
79	11.36	21	4.27	1822	1 1 .		
70	12.88	23	3.77	1792	1 2 .		
61	14.71	27	3.3	1783	1 4 .		
55	16.37	30	2.97	1786	1 6 .		
50	18.05	33	2.69	1750	1 8 .		
45	19.86	36	2.45	1719	2 0 .		
39	23.27	42	2.09	1712	2 2 .		
32	27.92	51	1.75	1634	2 8 .		
28	32.54	59	1.5	1631	3 2 .		
25	36.16	66	1.35	1540	3 6 .		
21	43.54	80	1.05	1496	4 5 .		
15	58.46	105	0.85	730	M 0 1 3 2 5 6 . _ M _ _ _ _ . 1 8 C - -	15.5	71
34	26.4	48	3.29	4000	M 0 2 2 2 2 8 . _ M _ _ _ _ . 1 8 C - -	18.5	71
28	31.68	58	2.74	4000	3 2 .		
25	35.69	65	2.44	4000	3 6 .		
22	41.49	76	2.09	3824	4 5 .		
19	47.09	86	1.85	3706	5 0 .		
17	53.54	98	1.63	3571	5 6 .		
16	57.03	103	1.54	3829	M 0 2 3 2 5 6 . _ M _ _ _ _ . 1 8 C - -	19.5	71
14	62.87	114	1.4	3685	6 3 .		
13	69.19	125	1.27	3532	7 1 .		
11	81.07	147	1.08	3243	8 0 .		
9.3	97.26	176	0.91	3270	1 0 0		
28	31.68	58	3.58	4000	M 0 3 2 2 3 2 . _ M _ _ _ _ . 1 8 C - -	18.5	71
25	35.69	65	3.19	4000	3 6 .		
22	41.49	76	2.69	4000	4 5 .		
19	47.09	86	2.41	4000	5 0 .		
17	53.54	98	2.09	4000	5 6 .		
16	57.03	103	2.02	4000	M 0 3 3 2 5 6 . _ M _ _ _ _ . 1 8 C - -	19.5	71
14	62.87	114	1.82	4000	6 3 .		
13	69.19	125	1.66	3441	7 1 .		
11	81.07	147	1.42	3243	8 0 .		
9.3	97.26	176	1.18	3039	1 0 0		
7.9	113.37	205	1.02	2493	1 1 2		
7.1	125.97	228	0.92	1766	1 2 5		
15	58.38	106	3.17	7200	M 0 4 3 2 5 6 . _ M _ _ _ _ . 1 8 C - -	28.5	71
14	64.29	117	2.88	7200	6 3 .		
12	73.95	134	2.51	7200	7 1 .		
11	80.4	146	2.31	7200	8 0 .		
9.3	96.52	175	1.92	7200	1 0 0		
7.8	115.82	210	1.6	6442	1 1 2		
6.9	130.5	236	1.43	6712	1 2 5		
5.9	151.71	276	1.22	6295	1 6 0		
5.2	172.19	312	1.08	5901	1 8 0		
4.6	195.75	354	0.95	6203	2 0 0		
3.9	232.81	412	0.82	7125	M 0 4 4 2 2 2 5 _ M _ _ _ _ . 1 8 C - -	40.5	71
12	73.95	135	3.33	7200	M 0 5 3 2 7 1 . _ M _ _ _ _ . 1 8 C - -	28.5	71
11	80.4	146	3.06	7200	8 0 .		
9.3	96.52	175	2.56	7200	1 0 0		
7.8	115.82	210	2.14	7200	1 1 2		
6.9	130.5	237	1.9	7200	1 2 5		
5.9	151.71	276	1.63	6195	1 6 0		
5.2	172.19	313	1.44	5820	1 8 0		
4.6	195.75	355	1.27	5274	2 0 0		
3.9	232.81	413	1.09	4809	M 0 5 4 2 2 2 5 _ M _ _ _ _ . 1 8 C - -	41.5	71
3.5	260.47	461	0.97	4809	2 5 0		
3.2	277.62	492	0.91	4809	2 8 0		
2.9	305.72	542	0.83	4809	3 0 0		
7.5	119.5	218	2.87	7200	M 0 6 3 2 1 1 2 _ M _ _ _ _ . 1 8 C - -	33.5	71
6.3	143.39	261	2.4	7200	1 2 5		
5.6	161.57	293	2.13	7200	1 6 0		
4.8	187.83	342	1.83	7200	1 8 0		
4.2	213.18	387	1.61	6215	2 0 0		
4.2	215.23	384	1.62	7200	M 0 6 4 2 2 2 5 _ M _ _ _ _ . 1 8 C - -	47.5	71
3.8	237.02	423	1.47	7200	2 5 0		
3.3	272.91	486	1.09	7200	2 8 0		
2.9	313.91	558	0.95	7200	3 0 0		
2.5	365.1	649	0.92	7200	3 6 0		
2.3	396.93	706	0.85	7200	4 0 0		
3.9	229	408	2.12	4677	M 0 7 4 2 2 2 5 _ M _ _ _ _ . 1 8 C - -	54.5	71
3.5	259.68	462	1.88	4676	2 5 0		
3.1	286.42	510	1.7	4676	2 8 0		
2.9	315.41	562	1.54	4676	3 0 0		
2.5	361.21	642	1.35	4675	3 6 0		
2.2	415.49	738	1.17	4675	4 0 0		
1.9	469.77	833	1.04	4675	4 5 0		
1.8	510.72	906	0.96	4675	5 0 0		
1.5	592.12	1048	0.83	4675	6 5 0		

NOTE
Other output speeds are available using 2 and 8 pole motors - Consult Application Engineering

SERIES M

SELECTION TABLES

GEARED MOTORS

0.25 kW

4 POLE

N2 R/MIN	i	M2 Nm	Fm	N	Unit Designation	Kg	Motor Size
Output Speed	Ratio	Output Torque	Service Factor	Overhung Load	Column Entry [1] Through [20] Spaces to be filled when entering order	Weight	
373	3.75	6	9.62	1670	M 0 1 2 2 3 . 6 - M - - - - . 2 5 A - -	14.5	71
276	5.07	8	8.07	1764	5 . 0		
243	5.76	9	7.53	1810	5 . 6		
214	6.53	10	6.95	1829	6 . 3		
168	8.35	13	5.75	1841	8 . 0		
156	9	14	5.41	1840	9 . 0		
123	11.36	18	4.48	1845	1 1 .		
109	12.88	21	4.09	1845	1 2 .		
95	14.71	24	3.7	1800	1 4 .		
86	16.37	26	3.33	1879	1 6 .		
78	18.05	29	3.02	1850	1 8 .		
70	19.86	32	2.75	1796	2 0 .		
60	23.27	38	2.34	1860	2 2 .		
50	27.92	45	1.96	1724	2 8 .		
43	32.54	53	1.68	1853	3 2 .		
39	36.16	59	1.52	1801	3 6 .		
32	43.54	71	1.17	1880	4 5 .		
28	49.91	81	0.88	1790	5 0 .		
24	58.46	94	0.95	1520	M 0 1 3 2 5 6 - M - - - - . 2 5 A - -	15.5	71
22	64.45	103	0.87	1230	6 3 .		
53	26.4	43	3.68	4000	M 0 2 2 2 2 8 - M - - - - . 2 5 A - -	18.5	71
44	31.68	52	3.07	4000	3 2 .		
39	35.69	58	2.73	4000	3 6 .		
34	41.49	68	2.35	4000	4 5 .		
30	47.09	77	2.07	4000	5 0 .		
26	53.54	87	1.82	3906	5 6 .		
25	57.03	92	1.73	4000	M 0 2 3 2 5 6 - M - - - - . 2 5 A - -	19.5	71
22	62.87	102	1.57	4000	6 3 .		
20	69.19	112	1.43	4000	7 1 .		
17	81.07	131	1.22	3812	8 0 .		
14	97.26	157	1.02	4000	1 0 0		
12	113.37	183	0.87	3950	1 1 2		
39	35.69	58	3.57	3837	M 0 3 2 2 3 6 - M - - - - . 2 5 A - -	18.5	71
34	41.49	68	2.91	3921	4 5 .		
30	47.09	77	2.63	3828	5 0 .		
26	53.54	87	2.34	3941	5 6 .		
25	57.03	92	2.26	3884	M 0 3 3 2 5 6 - M - - - - . 2 5 A - -	19.5	71
22	62.87	102	2.05	3772	6 3 .		
20	69.19	112	1.86	3443	7 1 .		
17	81.07	131	1.59	3812	8 0 .		
14	97.26	157	1.33	3251	1 0 0		
12	113.37	183	1.14	3950	1 1 2		
11	125.97	203	1.03	3390	1 2 5		
9.2	151.69	245	0.85	2209	1 6 0		
24	58.38	94	3.56	7200	M 0 4 3 2 5 6 - M - - - - . 2 5 A - -	28.5	71
22	64.29	104	3.23	7200	6 3 .		
19	73.95	120	2.81	7191	7 1 .		
17	80.4	130	2.58	7171	8 0 .		
15	96.52	156	2.16	7200	1 0 0		
12	115.82	187	1.8	6988	1 1 2		
11	130.5	211	1.6	7200	1 2 5		
9.2	151.71	245	1.37	7153	1 6 0		
8.1	172.19	278	1.21	6841	1 8 0		
7.2	195.75	317	1.07	7200	2 0 0		
6	232.81	366	0.92	7125	M 0 4 4 2 2 5 - M - - - - . 2 5 A - -	40.5	71
5.4	260.47	408	0.83	7125	2 5 0		
19	73.95	120	3.73	7200	M 0 5 3 2 7 1 - M - - - - . 2 5 A - -	28.5	71
17	80.4	131	3.43	7200	8 0 .		
15	96.52	157	2.87	6902	1 0 0		
12	115.82	188	2.39	6965	1 1 2		
11	130.5	211	2.12	6764	1 2 5		
9.2	151.71	246	1.83	6030	1 6 0		
8.1	172.19	279	1.61	6555	1 8 0		
7.2	195.75	317	1.42	5962	2 0 0		
6	232.81	368	1.22	4809	M 0 5 4 2 2 5 - M - - - - . 2 5 A - -	41.5	71
5.4	260.47	411	1.09	4809	2 5 0		
5	277.62	438	1.03	4809	2 8 0		
4.6	305.72	483	0.93	4809	3 0 0		
14	99.54	162	3.86	7200	M 0 6 3 2 1 0 0 - M - - - - . 2 5 A - -	33.5	71
12	119.5	194	3.22	7200	1 1 2		
10	143.39	232	2.69	7200	1 2 5		
8.7	161.57	262	2.39	7200	1 6 0		
7.5	187.83	305	2.05	7200	1 8 0		
6.6	213.18	346	1.81	7200	2 0 0		
6.5	215.23	342	1.82	7200	M 0 6 4 2 2 5 - M - - - - . 2 5 A - -	47.5	71
5.9	237.02	377	1.65	7200	2 5 0		
5.1	272.91	433	1.22	7200	2 8 0		
4.5	313.91	498	1.06	7200	3 0 0		
3.8	365.1	579	1.03	7200	3 6 0		
3.5	396.93	629	0.95	7200	4 0 0		
3.2	444.1	702	0.89	7200	4 5 0		
6.1	229	364	2.38	4677	M 0 7 4 2 2 5 - M - - - - . 2 5 A - -	54.5	71
5.4	259.68	412	2.1	4676	2 5 0		
4.9	286.42	454	1.91	4676	2 8 0		
4.4	315.41	501	1.73	4676	3 0 0		
3.9	361.21	572	1.51	4675	3 6 0		
3.4	415.49	658	1.32	4675	4 0 0		
3	469.77	743	1.17	4675	4 5 0		
2.7	510.72	807	1.07	4675	5 0 0		
2.4	592.12	934	0.93	4675	6 5 0		

NOTE
Other output speeds are available using 2 and 8 pole motors - Consult Application Engineering

SERIES M

SELECTION TABLES

GEARED MOTORS

0.25kW

6 POLE

N2 R/MIN	i	M2 Nm	Fm	N	Unit Designation	Kg	Motor Size
Output Speed	Ratio	Output Torque	Service Factor	Overhung Load	Column Entry [1] Through [20] Spaces to be filled when entering order	Weight	
240	3.75	9	7.09	1768	M 0 1 2 2 3 . 6 _ M _ _ _ _ . 2 5 C - -	14.5	71
178	5.07	13	5.81	1845	5 . 0		
156	5.76	14	5.29	1844	5 . 6		
138	6.53	16	4.76	1845	6 . 3		
108	8.35	21	3.97	1845	8 . 0		
100	9	23	3.75	1831	9 . 0		
79	11.36	29	3.08	1731	1 1 .		
70	12.88	33	2.71	1666	1 2 .		
61	14.71	37	2.38	1647	1 4 .		
55	16.37	41	2.14	1653	1 6 .		
50	18.05	46	1.94	1576	1 8 .		
45	19.86	50	1.76	1507	2 0 .		
39	23.27	59	1.51	1493	2 2 .		
32	27.92	71	1.26	1325	2 8 .		
28	32.54	83	1.08	1319	3 2 .		
25	36.16	92	0.97	1121	3 6 .		
44	20.23	51	3.08	4000	M 0 2 2 2 2 0 . _ M _ _ _ _ . 2 5 C - -	18.5	71
41	21.99	56	2.84	4000	2 2 .		
34	26.4	67	2.37	3771	2 8 .		
28	31.68	80	1.98	3813	3 2 .		
25	35.69	91	1.75	3712	3 6 .		
22	41.49	106	1.51	3619	4 5 .		
19	47.09	120	1.33	3365	5 0 .		
17	53.54	136	1.17	3071	5 6 .		
16	57.03	144	1.11	3630	M 0 2 3 2 5 6 . _ M _ _ _ _ . 2 5 C - -	19.5	71
14	62.87	159	1	3318	6 3 .		
13	69.19	174	0.92	2986	7 1 .		
41	21.99	56	3.7	3873	M 0 3 2 2 2 2 . _ M _ _ _ _ . 2 5 C - -	18.5	71
34	26.4	67	3.09	3771	2 8 .		
28	31.68	81	2.58	3695	3 2 .		
25	35.69	91	2.3	3695	3 6 .		
22	41.49	106	1.94	3562	4 5 .		
19	47.09	120	1.73	3508	5 0 .		
17	53.54	136	1.51	3419	5 6 .		
16	57.03	144	1.45	3331	M 0 3 3 2 5 6 . _ M _ _ _ _ . 2 5 C - -	19.5	71
14	62.87	159	1.31	3243	6 3 .		
13	69.19	174	1.2	2790	7 1 .		
11	81.07	204	1.02	2359	8 0 .		
9.3	97.26	245	0.85	1920	1 0 0		
15	58.38	148	2.28	6774	M 0 4 3 2 5 6 . _ M _ _ _ _ . 2 5 C - -	28.5	71
14	64.29	162	2.07	6944	6 3 .		
12	73.95	187	1.8	6749	7 1 .		
11	80.4	203	1.66	6620	8 0 .		
9.3	96.52	244	1.38	6609	1 0 0		
7.8	115.82	292	1.15	5558	1 1 2		
6.9	130.5	328	1.03	6144	1 2 5		
5.9	151.71	383	0.88	5239	1 6 0		
15	58.38	148	3.04	7200	M 0 5 3 2 5 6 . _ M _ _ _ _ . 2 5 C - -	28.5	71
14	64.29	163	2.76	7200	6 3 .		
12	73.95	187	2.4	6652	7 1 .		
11	80.4	204	2.2	6594	8 0 .		
9.3	96.52	244	1.84	6315	1 0 0		
7.8	115.82	292	1.54	6146	1 1 2		
6.9	130.5	329	1.37	5841	1 2 5		
5.9	151.71	383	1.17	5023	1 6 0		
5.2	172.19	434	1.03	4280	1 8 0		
4.6	195.75	493	0.91	3331	2 0 0		
12	72.28	183	3.41	7200	M 0 6 3 2 6 3 . _ M _ _ _ _ . 2 5 C - -	33.5	71
11	79.6	202	3.09	7200	7 1 .		
10	91.56	232	2.69	7200	8 0 .		
9	99.54	252	2.48	7200	1 0 0		
7.5	119.5	302	2.07	6988	1 1 2		
6.3	143.39	362	1.73	6562	1 2 5		
5.6	161.57	408	1.53	6914	1 6 0		
4.8	187.83	475	1.32	6375	1 8 0		
4.2	213.18	538	1.16	5067	2 0 0		
4.2	215.23	534	1.17	7200	M 0 6 4 2 2 2 5 _ M _ _ _ _ . 2 5 C - -	47.5	71
3.8	237.02	588	1.06	7200	2 5 0		
3.9	229	567	1.53	4677	M 0 7 4 2 2 2 5 _ M _ _ _ _ . 2 5 C - -	54.5	71
3.5	259.68	642	1.35	4676	2 5 0		
3.1	286.42	708	1.22	4676	2 8 0		
2.9	315.41	780	1.11	4676	3 0 0		
2.5	361.21	892	0.97	4675	3 6 0		
2.2	415.49	1026	0.85	4675	4 0 0		

NOTE
Other output speeds are available using 2 and 8 pole motors - Consult Application Engineering

SERIES M

SELECTION TABLES

GEARED MOTORS

0.37 kW

4 POLE

N2 R/MIN	i	M2 Nm	Fm	N	Unit Designation	Kg	Motor Size
Output Speed	Ratio	Output Torque	Service Factor	Overhung Load	Column Entry <input type="text" value="1"/> Through <input type="text" value="20"/> Spaces to be filled when entering order	Weight	
373	3.75	9	6.5	1652	M 0 1 2 2 3 . 6 _ M _ _ _ _ . 3 7 A _ _	14.5	71
276	5.07	12	5.45	1740	5 0 .		
243	5.76	14	5.09	1782	5 . 6		
214	6.53	15	4.7	1782	6 . 3		
168	8.35	20	3.89	1787	8 . 0		
156	9	22	3.65	1785	9 . 0		
123	11.36	27	3.03	1795	1 1 .		
109	12.88	31	2.77	1795	1 2 .		
95	14.71	35	2.5	1708	1 4 .		
86	16.37	39	2.25	1860	1 6 .		
78	18.05	43	2.04	1804	1 8 .		
70	19.86	48	1.86	1701	2 0 .		
60	23.27	56	1.58	1824	2 2 .		
50	27.92	67	1.32	1562	2 8 .		
43	32.54	78	1.14	1810	3 2 .		
39	36.16	87	1.03	1710	3 6 .		
80	17.58	42	3.73	4000	M 0 2 2 2 1 8 . _ M _ _ _ _ . 3 7 A _ _	18.5	71
69	20.23	49	3.24	4000	2 0 .		
64	21.99	53	2.97	4000	2 2 .		
53	26.4	64	2.49	3963	2 8 .		
44	31.68	77	2.08	4000	3 2 .		
39	35.69	86	1.85	4000	3 6 .		
34	41.49	100	1.59	4000	4 5 .		
30	47.09	114	1.4	4000	5 0 .		
26	53.54	129	1.23	3819	5 6 .		
25	57.03	136	1.17	4000	M 0 2 3 2 5 6 . _ M _ _ _ _ . 3 7 A _ _	19.5	71
22	62.87	151	1.06	4000	6 3 .		
20	69.19	166	0.96	4000	7 1 .		
17	81.07	194	0.82	3640	8 0 .		
64	21.99	53	3.89	3856	M 0 3 2 2 2 2 . _ M _ _ _ _ . 3 7 A _ _	18.5	71
53	26.4	64	3.26	3681	2 8 .		
44	31.68	77	2.71	3727	3 2 .		
39	35.69	86	2.41	3560	3 6 .		
34	41.49	101	1.97	3786	4 5 .		
30	47.09	114	1.77	3533	5 0 .		
26	53.54	130	1.58	3840	5 6 .		
25	57.03	136	1.53	3686	M 0 3 3 2 5 6 . _ M _ _ _ _ . 3 7 A _ _	19.5	71
22	62.87	151	1.38	3383	6 3 .		
20	69.19	166	1.26	2930	7 1 .		
17	81.07	194	1.08	3640	8 0 .		
14	97.26	232	0.9	2560	1 0 0		
24	58.38	140	2.41	7087	M 0 4 3 2 5 6 . _ M _ _ _ _ . 3 7 A _ _	28.5	71
22	64.29	154	2.18	7200	6 3 .		
19	73.95	178	1.9	7176	7 1 .		
17	80.4	193	1.75	7123	8 0 .		
15	96.52	232	1.46	7200	1 0 0		
12	115.82	277	1.22	6793	1 1 2		
11	130.5	312	1.08	7200	1 2 5		
9.2	151.71	363	0.93	7110	1 6 0		
8.1	172.19	412	0.82	6510	1 8 0		
24	58.38	141	3.18	7200	M 0 5 3 2 5 6 . _ M _ _ _ _ . 3 7 A _ _	28.5	71
22	64.29	155	2.9	7200	6 3 .		
19	73.95	178	2.52	6687	7 1 .		
17	80.4	193	2.32	7005	8 0 .		
15	96.52	232	1.94	6393	1 0 0		
12	115.82	278	1.62	6563	1 1 2		
11	130.5	313	1.44	6018	1 2 5		
9.2	151.71	364	1.23	4950	1 6 0		
8.1	172.19	413	1.09	5960	1 8 0		
7.2	195.75	469	0.96	4820	2 0 0		
6	232.81	545	0.82	4809	M 0 5 4 2 2 2 5 _ M _ _ _ _ . 3 7 A _ _	41.5	71
19	72.28	173	3.6	7200	M 0 6 3 2 6 3 . _ M _ _ _ _ . 3 7 A _ _	33.5	71
18	79.6	192	3.24	7200	7 1 .		
15	91.56	220	2.84	7200	8 0 .		
14	99.54	240	2.61	7200	1 0 0		
12	119.5	287	2.17	7200	1 1 2		
10	143.39	344	1.82	7200	1 2 5		
8.7	161.57	388	1.61	7200	1 6 0		
7.5	187.83	451	1.39	7200	1 8 0		
6.6	213.18	512	1.22	7200	2 0 0		
6.5	215.23	507	1.23	7200	M 0 6 4 2 2 2 5 _ M _ _ _ _ . 3 7 A _ _	47.5	71
5.9	237.02	559	1.12	7200	2 5 0		
5.1	272.91	641	0.82	7200	2 8 0		
6.1	229	539	1.61	4677	M 0 7 4 2 2 2 5 _ M _ _ _ _ . 3 7 A _ _	54.5	71
5.4	259.68	610	1.42	4676	2 5 0		
4.9	286.42	672	1.29	4676	2 8 0		
4.4	315.41	741	1.17	4676	3 0 0		
3.9	361.21	847	1.02	4675	3 6 0		
3.4	415.49	974	0.89	4675	4 0 0		

NOTE

Other output speeds are available using 2 and 8 pole motors - Consult Application Engineering

SERIES M

SELECTION TABLES

GEARED MOTORS

0.37 kW

6 POLE

N2 R/MIN	i	M2 Nm	Fm	N	Unit Designation	Kg	Motor Size
Output Speed	Ratio	Output Torque	Service Factor	Overhung Load	Column Entry [1] Through [20] Spaces to be filled when entering order	Weight	
245	3.75	13	4.9	1730	M 0 1 2 2 3 . 6 _ M _ _ _ _ . 3 7 C - -	18.5	80A
182	5.07	18	4.01	1795	5 . 0		
160	5.76	21	3.65	1792	5 . 6		
141	6.53	24	3.29	1795	6 . 3		
110	8.35	30	2.75	1795	8 . 0		
102	9	33	2.59	1767	9 . 0		
81	11.36	42	2.12	1575	1 1 .		
71	12.88	47	1.88	1451	1 2 .		
63	14.71	54	1.64	1415	1 4 .		
56	16.37	60	1.48	1425	1 6 .		
51	18.05	66	1.34	1278	1 8 .		
46	19.86	73	1.22	1146	2 0 .		
40	23.27	86	1.04	1117	2 2 .		
33	27.92	103	0.87	795	2 8 .		
74	12.37	46	3.47	4000	M 0 2 2 2 1 2 . _ M _ _ _ _ . 3 7 C - -	22.5	80A
65	14.05	52	3.06	4000	1 4 .		
58	15.97	59	2.69	4000	1 6 .		
52	17.58	65	2.45	4000	1 8 .		
45	20.23	75	2.13	3841	2 0 .		
42	21.99	81	1.96	3765	2 2 .		
35	26.4	97	1.63	3380	2 8 .		
29	31.68	117	1.36	3493	3 2 .		
26	35.69	131	1.21	3220	3 6 .		
22	41.49	153	1.04	3267	4 5 .		
20	47.09	174	0.92	2779	5 0 .		
17	53.54	197	0.81	2215	5 6 .		
58	15.97	59	3.52	4000	M 0 3 2 2 1 6 . _ M _ _ _ _ . 3 7 C - -	22.5	80A
52	17.58	65	3.19	3933	1 8 .		
45	20.23	75	2.77	3768	2 0 .		
42	21.99	81	2.56	3657	2 2 .		
35	26.4	97	2.13	3380	2 8 .		
29	31.68	117	1.78	3173	3 2 .		
26	35.69	131	1.59	3173	3 6 .		
22	41.49	153	1.34	2812	4 5 .		
20	47.09	173	1.2	2666	5 0 .		
17	53.54	197	1.04	2423	5 6 .		
16	57.03	208	1	2186	M 0 3 3 2 5 6 . _ M _ _ _ _ . 3 7 C - -	23.5	80A
15	62.87	230	0.91	1945	6 3 .		
13	69.19	252	0.83	1674	7 1 .		
34	27.3	101	3.34	7200	M 0 4 2 2 2 8 . _ M _ _ _ _ . 3 7 C - -	30.5	80A
29	32.19	119	2.82	7200	3 2 .		
26	35.25	130	2.58	7200	3 6 .		
21	43.2	159	2.11	7200	4 5 .		
19	48.15	178	1.9	7200	5 0 .		
17	54	199	1.35	7200	5 6 .		
16	58.38	214	1.58	6045	M 0 4 3 2 5 6 . _ M _ _ _ _ . 3 7 C - -	32.5	80A
14	64.29	235	1.43	6506	6 3 .		
12	73.95	271	1.25	5976	7 1 .		
11	80.4	294	1.15	5626	8 0 .		
10	96.52	353	0.96	5597	1 0 0		
29	32.19	119	3.76	7200	M 0 5 2 2 3 2 . _ M _ _ _ _ . 3 7 C - -	31.5	80A
26	35.25	130	3.44	7200	3 6 .		
21	43.2	160	2.54	7200	4 5 .		
19	48.15	178	2.13	7200	5 0 .		
17	54	199	1.35	7200	5 6 .		
16	58.38	214	2.1	6391	M 0 5 3 2 5 6 . _ M _ _ _ _ . 3 7 C - -	32.5	80A
14	64.29	236	1.9	6204	6 3 .		
12	73.95	271	1.66	5713	7 1 .		
11	80.4	295	1.52	5556	8 0 .		
10	96.52	353	1.27	4800	1 0 0		
7.9	115.82	423	1.06	4339	1 1 2		
7	130.5	477	0.94	3513	1 2 5		
6.1	151.71	555	0.81	3013	1 6 0		
15	59.61	220	2.13	7200	M 0 6 2 2 5 6 . _ M _ _ _ _ . 3 7 C - -	36.5	80A

NOTE

Other output speeds are available using 2 and 8 pole motors - Consult Application Engineering

SERIES M

SELECTION TABLES

GEARED MOTORS

0.37 kW

6 POLE

N2 R/MIN	i	M2 Nm	Fm	N	Unit Designation	Kg	Motor Size
Output Speed	Ratio	Output Torque	Service Factor	Overhung Load	Column Entry [1] Through [20] Spaces to be filled when entering order	Weight	
13	72.28	265	2.36	7200	M 0 6 3 2 6 3 . _ M _ _ _ _ . 3 7 C - -	37.5	80A
12	79.6	292	2.14	7008	7 1 .		
10	91.56	336	1.86	6645	8 0 .		
9.2	99.54	365	1.71	6403	1 0 0		
7.7	119.5	438	1.43	6626	1 1 2		
6.4	143.39	525	1.19	5470	1 2 5		
5.7	161.57	590	1.06	6424	1 6 0		
4.9	187.83	688	0.91	4961	1 8 0		
4.3	213.18	779	0.8	3099	2 0 0		
4.3	215.23	773	0.81	7200	M 0 6 4 2 2 2 5 _ M _ _ _ _ . 3 7 C - -	50.5	80A
16	58.95	216	3.99	10000	M 0 7 3 2 5 6 . _ M _ _ _ _ . 3 7 C - -	48.5	80A
15	62.83	231	3.76	10000	6 3 .		
12	74.47	274	3.16	10000	7 1 .		
12	79.51	291	2.98	10000	8 0 .		
9.3	98.66	361	2.4	10000	1 0 0		
7.9	116.34	426	2.04	10000	1 1 2		
7.2	127.39	466	1.86	10000	1 2 5		
5.9	156.12	569	1.54	10000	1 6 0		
5.3	174.01	635	1.39	8970	1 8 0		
4.7	195.15	711	1.25	7760	2 0 0		
4	229	821	1.06	4677	M 0 7 4 2 2 2 5 _ M _ _ _ _ . 3 7 C - -	57.5	80A
3.5	259.68	929	0.93	4676	2 5 0		
3.2	286.42	1025	0.85	4676	2 8 0		
4	228.91	821	1.66	18916	M 0 8 4 2 2 2 5 _ M _ _ _ _ . 3 7 C - -	105.5	80A
3.6	258.98	928	1.58	17870	2 5 0		
3.1	301.21	1079	1.36	17870	2 8 0		
2.7	337.01	1206	1.21	17870	3 0 0		
2.6	359.19	1286	1.14	17870	3 6 0		
2.2	425.69	1523	0.96	17870	4 0 0		
1.9	480.51	1717	0.9	16792	4 5 0		
1.8	513.04	1833	0.84	16792	5 0 0		
4	231.06	837	3.16	25710	M 0 9 4 1 2 2 5 _ M _ _ _ _ . 3 7 C - -	149.5	80A
3.6	258.09	933	3.06	24951	2 5 0		
3.1	300.18	1085	2.63	24951	2 8 0		
2.7	335.85	1212	2.36	24951	3 0 0		
2.6	357.95	1293	2.21	24951	3 6 0		
2.2	424.23	1531	1.87	24951	4 0 0		
2	471.32	1699	1.68	24951	4 5 0		
1.8	503.22	1813	1.58	24951	5 0 0		
1.5	624.45	2246	1.27	24951	6 5 0		
1.2	736.35	2644	1.08	24951	7 3 0		
1	882.06	3161	0.9	24951	8 6 0		
0.34	2743.72	9589	1.11	80613	M 1 4 5 1 2 7 C _ M _ _ _ _ . 3 7 C - -	406.5	80A
0.27	3404.7	11873	0.9	80613	3 2 C		

NOTE

Other output speeds are available using 2 and 8 pole motors - Consult Application Engineering

SERIES M

SELECTION TABLES

GEARED MOTORS

0.55 kW

4 POLE

N2 R/MIN	i	M2 Nm	Fm	N	Unit Designation	Kg	Motor Size
Output Speed	Ratio	Output Torque	Service Factor	Overhung Load	Column Entry [1] Through [20] Spaces to be filled when entering order	Weight	
379	3.75	13	4.43	1625	M 0 1 2 2 3 . 6 _ M _ _ _ _ . 5 5 A - -	18.5	80A
280	5.07	18	3.72	1705	5 . 0		
246	5.76	20	3.47	1740	5 . 6		
218	6.53	23	3.21	1711	6 . 3		
170	8.35	29	2.65	1706	8 . 0		
158	9	32	2.49	1703	9 . 0		
125	11.36	40	2.07	1720	1 1 .		
110	12.88	46	1.89	1720	1 2 .		
97	14.71	52	1.7	1570	1 4 .		
87	16.37	58	1.54	1831	1 6 .		
79	18.05	64	1.39	1736	1 8 .		
71	19.86	70	1.27	1558	2 0 .		
61	23.27	82	1.08	1770	2 2 .		
51	27.92	99	0.9	1320	2 8 .		
127	11.15	39	3.63	4000	M 0 2 2 2 1 1 . _ M _ _ _ _ . 5 5 A - -	22.5	80A
115	12.37	44	3.35	4000	1 2 .		
101	14.05	50	3.04	4000	1 4 .		
89	15.97	57	2.8	4000	1 6 .		
81	17.58	62	2.55	3942	1 8 .		
70	20.23	72	2.21	3885	2 0 .		
65	21.99	78	2.03	4000	2 2 .		
54	26.4	94	1.7	3908	2 8 .		
45	31.68	112	1.42	4000	3 2 .		
40	35.69	126	1.26	4000	3 6 .		
34	41.49	147	1.08	4000	4 5 .		
30	47.09	167	0.95	4000	5 0 .		
27	53.54	190	0.84	3690	5 6 .		
101	14.05	50	3.85	4000	M 0 3 2 2 1 4 . _ M _ _ _ _ . 5 5 A - -	22.5	80A
89	15.97	56	3.6	3972	1 6 .		
81	17.58	62	3.31	3934	1 8 .		
70	20.23	72	2.88	3798	2 0 .		
65	21.99	78	2.65	3719	2 2 .		
54	26.4	93	2.23	3380	2 8 .		
45	31.68	112	1.85	3469	3 2 .		
40	35.69	127	1.65	3143	3 6 .		
34	41.49	148	1.34	3584	4 5 .		
30	47.09	167	1.21	3091	5 0 .		
27	53.54	190	1.08	3690	5 6 .		
25	57.03	200	1.04	3390	M 0 3 3 2 5 6 . _ M _ _ _ _ . 5 5 A - -	23.5	80A
23	62.87	221	0.94	2800	6 3 .		
21	69.19	243	0.86	2160	7 1 .		
52	27.3	97	3.44	7200	M 0 4 2 2 2 8 . _ M _ _ _ _ . 5 5 A - -	30.5	80A
44	32.19	115	2.94	7200	3 2 .		
40	35.25	125	2.69	7200	3 6 .		
33	43.2	154	2.19	7200	4 5 .		
29	48.15	171	1.98	7200	5 0 .		
26	54	191	1.41	7200	5 6 .		
24	58.38	205	1.64	6917	M 0 4 3 2 5 6 . _ M _ _ _ _ . 5 5 A - -	32.5	80A
22	64.29	227	1.49	7200	6 3 .		
19	73.95	261	1.29	7154	7 1 .		
18	80.4	283	1.19	7050	8 0 .		
15	96.52	340	0.99	7200	1 0 0		
12	115.82	407	0.83	6500	1 1 2		
44	32.19	115	3.9	7200	M 0 5 2 2 3 2 . _ M _ _ _ _ . 5 5 A - -	31.5	80A
40	35.25	125	3.58	7200	3 6 .		
33	43.2	154	2.3	7200	4 5 .		
29	48.15	171	2.12	7200	5 0 .		
26	54	191	1.41	7200	5 6 .		
24	58.38	207	2.17	6869	M 0 5 3 2 5 6 . _ M _ _ _ _ . 5 5 A - -	32.5	80A
22	64.29	227	1.98	6652	6 3 .		
19	73.95	261	1.72	5918	7 1 .		
18	80.4	284	1.58	6714	8 0 .		
15	96.52	340	1.32	5629	1 0 0		
12	115.82	408	1.1	5960	1 1 2		
11	130.5	459	0.98	4900	1 2 5		
9.4	151.71	534	0.84	3329	1 6 0		
27	53.49	190	2.76	7200	M 0 6 2 2 5 0 . _ M _ _ _ _ . 5 5 A - -	36.5	80A
24	59.61	212	2.21	7200	5 6 .		

NOTE
Other output speeds are available using 2 and 8 pole motors - Consult Application Engineering

SERIES M

SELECTION TABLES

GEARED MOTORS

0.55 kW

4 POLE

N2 R/MIN	i	M2 Nm	Fm	N	Unit Designation	Kg	Motor Size
Output Speed	Ratio	Output Torque	Service Factor	Overhung Load	Column Entry [1] Through [20] Spaces to be filled when entering order	Weight	
20	72.28	254	2.46	7200	M 0 6 3 2 6 3 . _ M _ _ _ _ . 5 5 A - -	37.5	80A
18	79.6	282	2.21	7200	7 1 .		
16	91.56	322	1.94	7200	8 0 .		
14	99.54	351	1.78	7200	1 0 0		
12	119.5	422	1.48	7200	1 1 2		
10	143.39	505	1.24	7200	1 2 5		
8.8	161.57	568	1.1	7200	1 6 0		
7.6	187.83	662	0.95	7200	1 8 0		
6.7	213.18	751	0.83	7200	2 0 0		
6.6	215.23	743	0.84	7200	M 0 6 4 2 2 2 5 _ M _ _ _ _ . 5 5 A - -	50.5	80A
24	58.95	208	3.61	10000	M 0 7 3 2 5 6 . _ M _ _ _ _ . 5 5 A - -	48.5	80A
23	62.83	221	3.47	10000	6 3 .		
19	74.47	263	3.1	10000	7 1 .		
18	79.51	280	2.97	10000	8 0 .		
14	98.66	348	2.49	10000	1 0 0		
12	116.34	409	2.12	10000	1 1 2		
11	127.39	447	1.94	10000	1 2 5		
9.1	156.12	548	1.58	10000	1 6 0		
8.2	174.01	611	1.42	9140	1 8 0		
7.3	195.15	684	1.27	7940	2 0 0		
6.2	229	790	1.1	4677	M 0 7 4 2 2 2 5 _ M _ _ _ _ . 5 5 A - -	57.5	80A
5.5	259.68	894	0.97	4676	2 5 0		
5	286.42	986	0.88	4676	2 8 0		
12	119.19	419	3.94	20000	M 0 8 3 2 1 1 2 _ M _ _ _ _ . 5 5 A - -	76.5	80A
11	130.92	461	3.58	20000	1 2 5		
8.9	160.45	565	2.92	20000	1 6 0		
8.1	175.21	617	2.67	20000	1 8 0		
7	201.75	707	2.33	20000	2 0 0		
6.2	228.91	788	1.73	18916	M 0 8 4 2 2 2 5 _ M _ _ _ _ . 5 5 A - -	105.5	80A
5.5	258.98	891	1.64	17870	2 5 0		
4.7	301.21	1036	1.41	17870	2 8 0		
4.2	337.01	1158	1.26	17870	3 0 0		
4	359.19	1235	1.18	17870	3 6 0		
3.3	425.69	1464	1	17870	4 0 0		
3	480.51	1650	0.93	16792	4 5 0		
2.8	513.04	1761	0.87	16792	5 0 0		
6.1	231.06	805	3.29	25710	M 0 9 4 1 2 2 5 _ M _ _ _ _ . 5 5 A - -	149.5	80A
5.5	258.09	898	3.18	24951	2 5 0		
4.7	300.18	1044	2.74	24951	2 8 0		
4.2	335.85	1166	2.45	24951	3 0 0		
4	357.95	1244	2.3	24951	3 6 0		
3.3	424.23	1473	1.94	24951	4 0 0		
3	471.32	1635	1.75	24951	4 5 0		
2.8	503.22	1745	1.64	24951	5 0 0		
2.3	624.45	2162	1.32	24951	6 5 0		
1.9	736.35	2546	1.12	24951	7 3 0		
1.6	882.06	3040	0.94	24951	8 6 0		
0.52	2743.72	9227	1.15	80613	M 1 4 5 1 2 7 C _ M _ _ _ _ . 5 5 A - -	406.5	80A
0.42	3404.7	11435	0.93	80613	3 2 C		

NOTE

Other output speeds are available using 2 and 8 pole motors - Consult Application Engineering

SERIES M

SELECTION TABLES

GEARED MOTORS

0.55 kW

6 POLE

N2 R/MIN	i	M2 Nm	Fm	N	Unit Designation	Kg	Motor Size
Output Speed	Ratio	Output Torque	Service Factor	Overhung Load	Column Entry [1] Through [20] Spaces to be filled when entering order	Weight	
245	3.75	20	3.29	1673	M 0 1 2 2 3 . 6 _ M _ _ _ _ . 5 5 C _ _	20	80B
182	5.07	28	2.7	1720			
160	5.76	31	2.46	1715			
141	6.53	36	2.21	1720			
110	8.35	46	1.85	1720			
102	9	49	1.74	1671			
81	11.36	62	1.43	1341			
71	12.88	71	1.26	1129			
63	14.71	81	1.1	1066			
56	16.37	90	0.99	1083			
51	18.05	99	0.9	830			
46	19.86	109	0.82	603			
146	6.3	34	3.96	4000	M 0 2 2 2 6 . 3 _ M _ _ _ _ . 5 5 C _ _	24	80B
115	8	44	3.28	4000			
101	9.09	50	2.98	4000			
82	11.15	62	2.54	4000			
74	12.37	68	2.33	4000			
65	14.05	77	2.06	4000			
58	15.97	88	1.81	4000			
52	17.58	97	1.64	3921			
45	20.23	111	1.43	3604			
42	21.99	121	1.32	3414			
35	26.4	145	1.1	2793			
29	31.68	174	0.92	3013			
26	35.69	196	0.82	2481			
101	9.09	50	3.78	4000	M 0 3 2 2 9 . 0 _ M _ _ _ _ . 5 5 C _ _	24	80B
82	11.15	61	3.29	4000			
74	12.37	68	3.05	4000			
65	14.05	77	2.68	4000			
58	15.97	88	2.37	4000			
52	17.58	97	2.14	3871			
45	20.23	112	1.86	3549			
42	21.99	121	1.72	3332			
35	26.4	145	1.44	2793			
29	31.68	174	1.2	2391			
26	35.69	195	1.07	2391			
22	41.49	228	0.9	1687			
20	47.09	258	0.81	1403			
53	17.39	96	3.5	7200	M 0 4 2 2 1 8 . _ M _ _ _ _ . 5 5 C _ _	32	80B
45	20.61	114	2.96	7200			
42	22	122	2.77	7200			
34	27.3	150	2.25	6720			
29	32.19	177	1.9	6835			
26	35.25	194	1.74	6675			
21	43.2	237	1.42	6266			
19	48.15	264	1.28	6393			
17	54	296	0.91	6939			
16	58.38	318	1.06	4951	M 0 4 3 2 5 6 . _ M _ _ _ _ . 5 5 C _ _	34	80B
14	64.29	350	0.96	5849			
12	73.95	403	0.84	4817			
45	20.61	114	3.94	6989	M 0 5 2 2 2 0 . _ M _ _ _ _ . 5 5 C _ _	33	80B
42	22	121	3.69	6929			
34	27.3	151	2.98	6700			
29	32.19	178	2.53	6491			
26	35.25	194	2.32	6491			
21	43.2	237	1.71	6249			
19	48.15	264	1.43	6053			
17	54	296	0.91	6678			
16	58.38	318	1.41	5177	M 0 5 3 2 5 6 . _ M _ _ _ _ . 5 5 C _ _	34	80B
14	64.29	351	1.28	4710			
12	73.95	404	1.11	4304			
11	80.4	439	1.02	3999			
10	96.52	525	0.86	2526			
27	33.8	187	3.35	7200	M 0 6 2 2 3 2 . _ M _ _ _ _ . 5 5 C _ _	38	80B
23	39.86	220	2.84	7200			
21	43.64	241	2.6	7200			
17	53.49	294	1.85	7200			
15	59.61	328	1.43	6908			

NOTE

Other output speeds are available using 2 and 8 pole motors - Consult Application Engineering

SERIES M

SELECTION TABLES

GEARED MOTORS

0.55 kW

6 POLE

N2 R/MIN	i	M2 Nm	Fm	N	Unit Designation	Kg	Motor Size
Output Speed	Ratio	Output Torque	Service Factor	Overhung Load	Column Entry [1] Through [20] Spaces to be filled when entering order	Weight	
13	72.28	394	1.59	7200	M 0 6 3 2 6 3 . _ M _ _ _ _ . 5 5 C - -	39	80B
12	79.6	435	1.44	6720	7 1 .		
10	91.56	500	1.25	5812	8 0 .		
9.2	99.54	543	1.15	5209	1 0 0		
7.7	119.5	652	0.96	6083	1 1 2		
6.4	143.39	781	0.8	3831	1 2 5		
22	42.21	231	3.75	10000	M 0 7 2 2 4 5 . _ M _ _ _ _ . 5 5 C - -	45	80B
19	48.56	266	2.63	10000	5 0 .		
17	53.96	294	2.02	10000	5 6 .		
16	58.95	322	2.68	9221	M 0 7 3 2 5 6 . _ M _ _ _ _ . 5 5 C - -	50	80B
15	62.83	343	2.53	9072	6 3 .		
12	74.47	408	2.13	8636	7 1 .		
12	79.51	433	2	8446	8 0 .		
9.3	98.66	537	1.61	8407	1 0 0		
7.9	116.34	633	1.37	7534	1 1 2		
7.2	127.39	693	1.25	7534	1 2 5		
5.9	156.12	846	1.03	5591	1 6 0		
5.3	174.01	945	0.94	4721	1 8 0		
4.7	195.15	1057	0.84	4084	2 0 0		
9	102.2	557	2.96	20000	M 0 8 3 2 1 0 0 _ M _ _ _ _ . 5 5 C - -	78	80B
7.7	119.19	648	2.54	20000	1 1 2		
7	130.92	711	2.32	20000	1 2 5		
5.7	160.45	876	1.88	20000	1 6 0		
5.3	175.21	952	1.73	20000	1 8 0		
4.6	201.75	1093	1.51	20000	2 0 0		
4	228.91	1221	1.12	18916	M 0 8 4 2 2 2 5 _ M _ _ _ _ . 5 5 C - -	107	80B
3.6	258.98	1380	1.06	17870	2 5 0		
3.1	301.21	1604	0.91	17870	2 8 0		
2.7	337.01	1792	0.82	17870	3 0 0		
6.3	145.2	791	3.12	29600	M 0 9 3 1 1 4 0 _ M _ _ _ _ . 5 5 C - -	129	80B
5.7	160.29	875	2.82	29500	1 6 0		
4	231.06	1244	2.13	25710	M 0 9 4 1 2 2 5 _ M _ _ _ _ . 5 5 C - -	151	80B
3.6	258.09	1388	2.06	24951	2 5 0		
3.1	300.18	1613	1.77	24951	2 8 0		
2.7	335.85	1802	1.59	24951	3 0 0		
2.6	357.95	1922	1.49	24951	3 6 0		
2.2	424.23	2275	1.26	24951	4 0 0		
2	471.32	2525	1.13	24951	4 5 0		
1.8	503.22	2695	1.06	24951	5 0 0		
1.5	624.45	3339	0.86	24951	6 5 0		
4.2	220.22	1179	3.74	41580	M 1 0 4 1 2 2 5 _ M _ _ _ _ . 5 5 C - -	213	80B
3.8	242.24	1297	3.4	41580	2 5 0		
3.3	278.36	1489	2.96	41580	2 8 0		
2.9	315.65	1686	2.62	41580	3 0 0		
2.6	348.16	1861	2.37	41580	3 6 0		
2.3	398.71	2130	2.07	41580	4 0 0		
2.1	443.06	2364	1.87	41580	4 5 0		
1.8	500.94	2670	1.65	41580	5 0 0		
1.6	580.78	3093	1.43	41580	6 5 0		
1.3	692.72	3683	1.2	41580	7 3 0		
1.1	828.21	4397	1	41580	8 6 0		
0.93	987.84	5238	0.84	41580	1 0 C		
2.8	325.33	1733	3.66	64632	M 1 3 4 1 3 0 0 _ M _ _ _ _ . 5 5 C - -	287	80B
2.6	358.84	1912	3.32	64632	3 6 0		
2.2	410.95	2189	2.9	64632	4 0 0		
2	463.22	2466	2.57	64632	4 5 0		
1.8	523.74	2786	2.28	64632	5 0 0		
1.5	607.22	3226	1.97	64632	6 5 0		
1.3	724.25	3842	1.65	64632	7 3 0		
1.1	858.69	4535	1.4	64632	8 6 0		
0.9	1024.19	5402	1.18	64632	1 0 C		
0.81	1140.7	6006	1.06	64632	1 1 C		
0.74	1249.19	6571	0.97	64632	1 3 C		
0.6	1528.11	8013	0.81	64690	1 5 C		
1.7	556.83	2961	3.64	80613	M 1 4 4 1 5 0 0 _ M _ _ _ _ . 5 5 C - -	403	80B
1.4	645.58	3429	3.14	80613	6 5 0		
1.2	770.01	4083	2.64	80613	7 3 0		
1.1	801.52	4244	2.51	80613	8 6 0		
0.99	929.27	4915	2.17	80613	1 0 C		
0.83	1108.37	5853	1.82	80613	1 1 C		
0.76	1213.79	6404	1.66	80613	1 3 C		
0.61	1502.21	7906	1.28	80711	1 5 C		
0.51	1802.65	9464	1.07	80711	1 8 C		
0.44	2074.02	10876	0.93	80711	2 0 C		
0.4	2304.47	12062	0.84	80711	2 4 C		

NOTE
Other output speeds are available using 2 and 8 pole motors - Consult Application Engineering

SERIES M

SELECTION TABLES

GEARED MOTORS

0.75 kW

4 POLE

N2 R/MIN	i	M2 Nm	Fm	N	Unit Designation	Kg	Motor Size
Output Speed	Ratio	Output Torque	Service Factor	Overhung Load	Column Entry [1] Through [20] Spaces to be filled when entering order	Weight	
377	3.75	18	3.24	1596	M 0 1 2 2 3 . 6 _ M _ _ _ _ . 7 5 A _ _	18.5	80A
279	5.07	24	2.72	1665			
246	5.76	28	2.54	1694			
217	6.53	32	2.34	1633			
169	8.35	40	1.94	1616			
157	9	44	1.82	1612			
125	11.36	55	1.51	1636			
110	12.88	63	1.38	1636			
96	14.71	72	1.25	1417			
86	16.37	79	1.12	1800			
78	18.05	88	1.02	1660			
71	19.86	96	0.93	1400			
177	8	39	3.47	4000	M 0 2 2 2 8 . 0 _ M _ _ _ _ . 7 5 A _ _	22.5	80A
156	9.09	44	3.14	4000			
127	11.15	54	2.65	4000			
114	12.37	60	2.45	4000			
101	14.05	68	2.22	4000			
89	15.97	78	2.04	3968			
80	17.58	85	1.86	3878			
70	20.23	99	1.61	3757			
64	21.99	107	1.48	4000			
54	26.4	128	1.24	3847			
45	31.68	154	1.04	4000			
40	35.69	173	0.92	4000			
156	9.09	44	3.76	4000	M 0 3 2 2 9 . 0 _ M _ _ _ _ . 7 5 A _ _	22.5	80A
127	11.15	54	3.28	4000			
114	12.37	60	3.07	4000			
101	14.05	69	2.81	4000			
89	15.97	77	2.63	3957			
80	17.58	85	2.42	3898			
70	20.23	99	2.11	3689			
64	21.99	107	1.94	3568			
54	26.4	128	1.63	3045			
45	31.68	154	1.35	3182			
40	35.69	173	1.2	2680			
34	41.49	202	0.98	3360			
30	47.09	229	0.88	2600			
81	17.39	85	3.64	6430	M 0 4 2 2 1 8 . _ M _ _ _ _ . 7 5 A _ _	30.5	80A
69	20.61	100	3.16	6750			
64	22	107	2.99	6880			
52	27.3	133	2.51	7052			
44	32.19	157	2.15	7124			
40	35.25	172	1.96	7147			
33	43.2	211	1.6	6970			
29	48.15	234	1.44	7178			
26	54	262	1.03	7200			
24	58.38	281	1.2	6729	M 0 4 3 2 5 6 . _ M _ _ _ _ . 7 5 A _ _	32.5	80A
22	64.29	310	1.09	7200			
19	73.95	357	0.95	7130			
18	80.4	388	0.87	6970			
52	27.3	134	3.36	6723	M 0 5 2 2 2 8 . _ M _ _ _ _ . 7 5 A _ _	31.5	80A
44	32.19	157	2.85	6875			
40	35.25	172	2.62	6769			
33	43.2	210	1.68	6865			
29	48.15	234	1.55	6658			
26	54	262	1.03	7200			
24	58.38	283	1.59	6502	M 0 5 3 2 5 6 . _ M _ _ _ _ . 7 5 A _ _	32.5	80A
22	64.29	311	1.44	6044			
19	73.95	358	1.26	5064			
18	80.4	389	1.16	6390			
15	96.52	466	0.97	4780			
42	33.8	165	3.77	7200	M 0 6 2 2 3 2 . _ M _ _ _ _ . 7 5 A _ _	36.5	80A
36	39.86	194	3.21	7200			
32	43.64	213	2.93	7200			
26	53.49	260	2.02	7200			
24	59.61	291	1.61	7200			

NOTE
Other output speeds are available using 2 and 8 pole motors - Consult Application Engineering

SERIES M

SELECTION TABLES

GEARED MOTORS

0.75 kW

4 POLE

N2 R/MIN	i	M2 Nm	Fm	N	Unit Designation	Kg	Motor Size
Output Speed	Ratio	Output Torque	Service Factor	Overhung Load	Column Entry <input type="text" value="1"/> Through <input type="text" value="20"/> Spaces to be filled when entering order	Weight	
20	72.28	348	1.8	7200	M 0 6 3 2 6 3 . _ M _ _ _ _ . 7 5 A - -	37.5	80A
18	79.6	386	1.61	7200	7 1 .		
15	91.56	441	1.42	7200	8 0 .		
14	99.54	481	1.3	7200	1 0 0		
12	119.5	577	1.08	7200	1 1 2		
10	143.39	691	0.91	7200	1 2 5		
29	48.56	235	2.97	10000	M 0 7 2 2 5 0 . _ M _ _ _ _ . 7 5 A - -	43.5	80A
26	53.96	261	2.28	10000	5 6 .		
24	58.95	285	2.64	9458	M 0 7 3 2 5 6 . _ M _ _ _ _ . 7 5 A - -	48.5	80A
23	62.83	303	2.54	9349	6 3 .		
19	74.47	359	2.26	9454	7 1 .		
18	79.51	383	2.17	9288	8 0 .		
14	98.66	476	1.82	8661	1 0 0		
12	116.34	560	1.55	8450	1 1 2		
11	127.39	612	1.42	7996	1 2 5		
9.1	156.12	751	1.16	6910	1 6 0		
8.1	174.01	837	1.04	5530	1 8 0		
7.3	195.15	936	0.93	3899	2 0 0		
6.2	229	1081	0.8	4677	M 0 7 4 2 2 2 5 _ M _ _ _ _ . 7 5 A - -	57.5	80A
14	102.2	493	3.34	20000	M 0 8 3 2 1 0 0 _ M _ _ _ _ . 7 5 A - -	76.5	80A
12	119.19	573	2.88	19337	1 1 2		
11	130.92	630	2.62	19051	1 2 5		
8.8	160.45	773	2.13	19410	1 6 0		
8.1	175.21	845	1.95	18989	1 8 0		
7	201.75	968	1.7	18252	2 0 0		
6.2	228.91	1079	1.27	18916	M 0 8 4 2 2 2 5 _ M _ _ _ _ . 7 5 A - -	105.5	80A
5.5	258.98	1219	1.2	17870	2 5 0		
4.7	301.21	1418	1.03	17870	2 8 0		
4.2	337.01	1585	0.92	17870	3 0 0		
3.9	359.19	1691	0.87	17870	3 6 0		
10	145.2	700	3.53	29600	M 0 9 3 1 1 4 0 _ M _ _ _ _ . 7 5 A - -	127.5	80A
8.8	160.29	771	3.2	29600	1 6 0		
6.1	231.06	1101	2.4	25710	M 0 9 4 1 2 2 5 _ M _ _ _ _ . 7 5 A - -	149.5	80A
5.5	258.09	1228	2.33	24951	2 5 0		
4.7	300.18	1428	2	24951	2 8 0		
4.2	335.85	1596	1.79	24951	3 0 0		
4	357.95	1702	1.68	24951	3 6 0		
3.3	424.23	2016	1.42	24951	4 0 0		
3	471.32	2237	1.28	24951	4 5 0		
2.8	503.22	2388	1.2	24951	5 0 0		
2.3	624.45	2959	0.97	24951	6 5 0		
1.9	736.35	3485	0.82	24951	7 3 0		
5.8	242.24	1148	3.84	41580	M 1 0 4 1 2 5 0 _ M _ _ _ _ . 7 5 A - -	211.5	80A
5.1	278.36	1318	3.35	41580	2 8 0		
4.5	315.65	1493	2.95	41580	3 0 0		
4.1	348.16	1648	2.68	41580	3 6 0		
3.5	398.71	1886	2.34	41580	4 0 0		
3.2	443.06	2093	2.11	41580	4 5 0		
2.8	500.94	2365	1.87	41580	5 0 0		
2.4	580.78	2740	1.61	41580	6 5 0		
2	692.72	3264	1.35	41580	7 3 0		
1.7	828.21	3892	1.13	41580	8 6 0		
1.4	987.84	4638	0.95	41580	1 0 C		
1.2	1138.21	5332	0.83	41580	1 1 C		
3.9	358.84	1694	3.75	64632	M 1 3 4 1 3 6 0 _ M _ _ _ _ . 7 5 A - -	285.5	80A
3.4	410.95	1939	3.27	64632	4 0 0		
3.1	463.22	2185	2.91	64632	4 5 0		
2.7	523.74	2468	2.57	64632	5 0 0		
2.3	607.22	2859	2.22	64632	6 5 0		
2	724.25	3406	1.86	64632	7 3 0		
1.6	858.69	4016	1.58	64632	8 6 0		
1.4	1024.19	4785	1.33	64632	1 0 C		
1.2	1140.7	5319	1.19	64632	1 1 C		
1.1	1249.19	5821	1.09	64632	1 3 C		
0.93	1528.11	7097	0.91	64690	1 5 C		
2.2	645.58	3040	3.54	80613	M 1 4 4 1 6 5 0 _ M _ _ _ _ . 7 5 A - -	401.5	80A
1.8	770.01	3621	2.97	80613	7 3 0		
1.8	801.52	3760	2.83	80613	8 6 0		
1.5	929.27	4355	2.45	80613	1 0 C		
1.3	1108.37	5188	2.05	80613	1 1 C		
1.2	1213.79	5677	1.88	80613	1 3 C		
0.94	1502.21	7007	1.44	80711	1 5 C		
0.78	1802.65	8391	1.2	80711	1 8 C		
0.68	2074.02	9645	1.05	80711	2 0 C		
0.61	2304.47	10700	0.94	80711	2 4 C		
0.52	2743.72	12627	0.84	80613	M 1 4 5 1 2 7 C _ M _ _ _ _ . 7 5 A - -	406.5	80A

NOTE

Other output speeds are available using 2 and 8 pole motors - Consult Application Engineering

SERIES M

SELECTION TABLES

GEARED MOTORS

0.75 kW

6 POLE

N2 R/MIN	i	M2 Nm	Fm	N	Unit Designation	Kg	Motor Size
Output Speed	Ratio	Output Torque	Service Factor	Overhung Load	Column Entry [1] Through [20] Spaces to be filled when entering order	Weight	
245	3.75	28	2.41	1610	M 0 1 2 2 3 . 6 _ M _ _ _ _ . 7 5 C - -	23.5	90S
182	5.07	38	1.98	1636	5 . 0		
160	5.76	43	1.8	1630	5 . 6		
141	6.53	49	1.62	1636	6 . 3		
110	8.35	62	1.35	1636	8 . 0		
102	9	67	1.28	1565	9 . 0		
81	11.36	85	1.05	1081	1 1 .		
71	12.88	96	0.93	770	1 2 .		
63	14.71	110	0.81	678	1 4 .		
183	5.03	37	3.45	4000	M 0 2 2 2 5 . 0 _ M _ _ _ _ . 7 5 C - -	26.5	90S
166	5.55	41	3.19	4000	5 . 6		
146	6.3	47	2.9	4000	6 . 3		
115	8	60	2.4	4000	8 . 0		
101	9.09	68	2.18	4000	9 . 0		
82	11.15	84	1.87	4000	1 1 .		
74	12.37	93	1.71	4000	1 2 .		
65	14.05	106	1.51	4000	1 4 .		
58	15.97	120	1.33	4000	1 6 .		
52	17.58	132	1.21	3833	1 8 .		
45	20.23	152	1.05	3341	2 0 .		
42	21.99	165	0.97	3023	2 2 .		
35	26.4	198	0.81	2141	2 8 .		
166	5.55	41	3.8	4000	M 0 3 2 2 5 . 6 _ M _ _ _ _ . 7 5 C - -	26.5	90S
146	6.3	47	3.5	4000	6 . 3		
115	8	60	3.02	4000	8 . 0		
101	9.09	68	2.77	4000	9 . 0		
82	11.15	84	2.41	4000	1 1 .		
74	12.37	93	2.24	4000	1 2 .		
65	14.05	106	1.97	4000	1 4 .		
58	15.97	120	1.74	4000	1 6 .		
52	17.58	132	1.57	3801	1 8 .		
45	20.23	152	1.37	3306	2 0 .		
42	21.99	165	1.26	2971	2 2 .		
35	26.4	198	1.05	2141	2 8 .		
29	31.68	237	0.88	1521	3 2 .		
73	12.54	94	3.44	6590	M 0 4 2 2 1 2 . _ M _ _ _ _ . 7 5 C - -	35.5	90S
63	14.58	110	3.07	6880	1 4 .		
56	16.31	123	2.75	7100	1 6 .		
53	17.39	131	2.57	7050	1 8 .		
45	20.61	155	2.17	6996	2 0 .		
42	22	166	2.03	6915	2 2 .		
34	27.3	205	1.65	6186	2 8 .		
29	32.19	242	1.39	6429	3 2 .		
26	35.25	265	1.28	6093	3 6 .		
21	43.2	324	1.04	5229	4 5 .		
19	48.15	360	0.94	5497	5 0 .		
56	16.31	123	3.65	6381	M 0 5 2 2 1 6 . _ M _ _ _ _ . 7 5 C - -	36.5	90S
53	17.39	131	3.42	6708	1 8 .		
45	20.61	155	2.89	6755	2 0 .		
42	22	166	2.71	6628	2 2 .		
34	27.3	205	2.18	6145	2 8 .		
29	32.19	242	1.85	5704	3 2 .		
26	35.25	264	1.7	5704	3 6 .		
21	43.2	324	1.25	5192	4 5 .		
19	48.15	360	1.05	4778	5 0 .		
16	58.38	434	1.03	3829	M 0 5 3 2 5 6 . _ M _ _ _ _ . 7 5 C - -	37.5	90S
14	64.29	479	0.94	3050	6 3 .		
12	73.95	551	0.82	2739	7 1 .		
36	25.51	192	3.25	7200	M 0 6 2 2 2 2 . _ M _ _ _ _ . 7 5 C - -	41.5	90S
34	27.24	205	3.04	7200	2 8 .		
27	33.8	255	2.45	7200	3 2 .		
23	39.86	300	2.08	7010	3 6 .		
21	43.64	328	1.9	6813	4 5 .		
17	53.49	401	1.35	7193	5 0 .		
15	59.61	447	1.05	6584	5 6 .		

NOTE

Other output speeds are available using 2 and 8 pole motors - Consult Application Engineering

SERIES M

SELECTION TABLES

GEARED MOTORS

0.75 kW

6 POLE

N2 R/MIN	i	M2 Nm	Fm	N	Unit Designation	Kg	Motor Size
Output Speed	Ratio	Output Torque	Service Factor	Overhung Load	Column Entry [1] Through [20] Spaces to be filled when entering order	Weight	
13	72.28	538	1.16	7200	M 0 6 3 2 6 3 . _ M _ _ _ _ . 7 5 C - -	42.5	90S
12	79.6	593	1.05	6400	7 1 .		
10	91.56	682	0.92	4888	8 0 .		
9.2	99.54	741	0.84	3882	1 0 0		
29	32.12	241	3.59	9420	M 0 7 2 2 3 2 . _ M _ _ _ _ . 7 5 C - -	48.5	90S
26	35.17	264	3.28	9420	3 6 .		
22	42.21	315	2.75	9183	4 5 .		
19	48.56	363	1.93	9043	5 0 .		
17	53.96	402	1.48	9208	5 6 .		
16	58.95	439	1.97	8355	M 0 7 3 2 5 6 . _ M _ _ _ _ . 7 5 C - -	53.5	90S
15	62.83	468	1.85	8042	6 3 .		
12	74.47	556	1.56	7121	7 1 .		
12	79.51	590	1.47	6721	8 0 .		
9.3	98.66	733	1.18	6637	1 0 0		
7.9	116.34	864	1	4794	1 1 2		
7.2	127.39	946	0.92	4794	1 2 5		
16	55.8	416	3.72	20000	M 0 8 2 2 5 6 . _ M _ _ _ _ . 7 5 C - -	81.5	90S
14	66.02	490	3.36	20000	M 0 8 3 2 6 3 . _ M _ _ _ _ . 7 5 C - -	81.5	90S
12	74.69	556	2.96	20000	7 1 .		
11	84.31	626	2.63	20000	8 0 .		
9	102.2	759	2.17	18367	1 0 0		
7.7	119.19	884	1.87	17935	1 1 2		
7	130.92	970	1.7	17575	1 2 5		
5.7	160.45	1195	1.38	17044	1 6 0		
5.3	175.21	1299	1.27	16406	1 8 0		
4.6	201.75	1491	1.11	15789	2 0 0		
4	228.91	1665	0.82	18916	M 0 8 4 2 2 2 5 _ M _ _ _ _ . 7 5 C - -	112.5	90S
7.9	116.55	870	3.28	29500	M 0 9 3 1 1 1 2 _ M _ _ _ _ . 7 5 C - -	131.5	90S
7.2	128.66	960	2.98	29500	1 2 5		
6.3	145.2	1079	2.29	29442	1 4 0		
5.7	160.29	1193	2.07	29330	1 6 0		
4	231.06	1696	1.56	25710	M 0 9 4 1 2 2 5 _ M _ _ _ _ . 7 5 C - -	156.5	90S
3.6	258.09	1892	1.51	24951	2 5 0		
3.1	300.18	2200	1.3	24951	2 8 0		
2.7	335.85	2457	1.16	24951	3 0 0		
2.6	357.95	2621	1.09	24951	3 6 0		
2.2	424.23	3103	0.92	24951	4 0 0		
2	471.32	3444	0.83	24951	4 5 0		
4.2	220.22	1608	2.74	41580	M 1 0 4 1 2 2 5 _ M _ _ _ _ . 7 5 C - -	217.5	90S
3.8	242.24	1768	2.49	41580	2 5 0		
3.3	278.36	2031	2.17	41580	2 8 0		
2.9	315.65	2300	1.92	41580	3 0 0		
2.6	348.16	2538	1.74	41580	3 6 0		
2.3	398.71	2904	1.52	41580	4 0 0		
2.1	443.06	3224	1.37	41580	4 5 0		
1.8	500.94	3642	1.21	41580	5 0 0		
1.6	580.78	4217	1.05	41580	6 5 0		
1.3	692.72	5022	0.88	41580	7 3 0		
4.1	226.98	1653	3.84	64632	M 1 3 4 1 2 2 5 _ M _ _ _ _ . 7 5 C - -	292.5	90S
3.7	249.68	1818	3.49	64632	2 5 0		
3.2	286.9	2087	3.04	64632	2 8 0		
2.8	325.33	2363	2.69	64632	3 0 0		
2.6	358.84	2608	2.43	64632	3 6 0		
2.2	410.95	2985	2.13	64632	4 0 0		
2	463.22	3363	1.89	64632	4 5 0		
1.8	523.74	3799	1.67	64632	5 0 0		
1.5	607.22	4400	1.44	64632	6 5 0		
1.3	724.25	5239	1.21	64632	7 3 0		
1.1	858.69	6184	1.03	64632	8 6 0		
0.9	1024.19	7366	0.86	64632	1 0 C		
2.4	390.06	2836	3.74	80613	M 1 4 4 1 3 6 0 _ M _ _ _ _ . 7 5 C - -	408.5	90S
2.1	446.71	3245	3.26	80613	4 0 0		
1.9	492.49	3575	3.01	80613	4 5 0		
1.7	556.83	4038	2.67	80613	5 0 0		
1.4	645.58	4676	2.3	80613	6 5 0		
1.2	770.01	5568	1.93	80613	7 3 0		
1.1	801.52	5787	1.84	80613	8 6 0		
0.99	929.27	6702	1.59	80613	1 0 C		
0.83	1108.37	7982	1.33	80613	1 1 C		
0.76	1213.79	8732	1.22	80613	1 3 C		
0.61	1502.21	10781	0.94	80711	1 5 C		

NOTE
Other output speeds are available using 2 and 8 pole motors - Consult Application Engineering

SERIES M

SELECTION TABLES

GEARED MOTORS

1.1 kW

4 POLE

N2 R/MIN	i	M2 Nm	Fm	N	Unit Designation	Kg	Motor Size
Output Speed	Ratio	Output Torque	Service Factor	Overhung Load	Column Entry [1] Through [20] Spaces to be filled when entering order	Weight	
376	3.75	26	2.2	1543	M 0 1 2 2 3 . 6 _ M _ _ _ _ 1 . 1 A - -	23.5	90S
278	5.07	36	1.85	1596	5 . 0		
245	5.76	41	1.72	1613	5 . 6		
216	6.53	47	1.59	1496	6 . 3		
169	8.35	60	1.32	1459	8 . 0		
157	9	65	1.24	1452	9 . 0		
124	11.36	82	1.03	1490	1 1 .		
109	12.88	92	0.94	1490	1 2 .		
96	14.71	106	0.85	1150	1 4 .		
393	3.59	25	3.88	3750	M 0 2 2 2 3 . 6 _ M _ _ _ _ 1 . 1 A - -	26.5	90S
280	5.03	36	3.19	3950	5 . 0		
254	5.55	40	3.01	4000	5 . 6		
224	6.3	45	2.79	3992	6 . 3		
176	8	57	2.36	4000	8 . 0		
155	9.09	65	2.13	4000	9 . 0		
126	11.15	80	1.8	4000	1 1 .		
114	12.37	89	1.66	4000	1 2 .		
100	14.05	101	1.51	4000	1 4 .		
88	15.97	115	1.39	3913	1 6 .		
80	17.58	126	1.26	3767	1 8 .		
70	20.23	145	1.1	3534	2 0 .		
64	21.99	158	1.01	4000	2 2 .		
53	26.4	189	0.84	3740	2 8 .		
280	5.03	36	3.73	3920	M 0 3 2 2 5 . 0 _ M _ _ _ _ 1 . 1 A - -	26.5	90S
254	5.55	39	3.51	3970	5 . 6		
224	6.3	45	3.24	3990	6 . 3		
176	8	57	2.78	4000	8 . 0		
155	9.09	65	2.55	4000	9 . 0		
126	11.15	80	2.23	4000	1 1 .		
114	12.37	89	2.09	4000	1 2 .		
100	14.05	101	1.91	4000	1 4 .		
88	15.97	114	1.79	3931	1 6 .		
80	17.58	126	1.64	3836	1 8 .		
70	20.23	145	1.43	3498	2 0 .		
64	21.99	158	1.32	3303	2 2 .		
53	26.4	189	1.11	2459	2 8 .		
45	31.68	227	0.92	2680	3 2 .		
40	35.69	255	0.82	1870	3 6 .		
112	12.54	90	3.13	5720	M 0 4 2 2 1 2 . _ M _ _ _ _ 1 . 1 A - -	35.5	90S
97	14.58	105	2.8	5940	1 4 .		
86	16.31	117	2.6	6130	1 6 .		
81	17.39	125	2.48	6229	1 8 .		
68	20.61	148	2.15	6512	2 0 .		
64	22	158	2.03	6624	2 2 .		
52	27.3	196	1.71	6794	2 8 .		
44	32.19	231	1.46	6991	3 2 .		
40	35.25	253	1.33	7055	3 6 .		
33	43.2	310	1.09	6568	4 5 .		
29	48.15	344	0.98	7140	5 0 .		
24	58.38	414	0.82	6400	M 0 4 3 2 5 6 . _ M _ _ _ _ 1 . 1 A - -	36.5	90S
86	16.31	117	3.82	5743	M 0 5 2 2 1 6 . _ M _ _ _ _ 1 . 1 A - -	36.5	90S
81	17.39	125	3.58	5832	1 8 .		
68	20.61	148	3.02	6042	2 0 .		
64	22	159	2.83	5957	2 2 .		
52	27.3	197	2.28	6188	2 8 .		
44	32.19	232	1.94	6307	3 2 .		
40	35.25	253	1.78	6015	3 6 .		
33	43.2	310	1.14	6279	4 5 .		
29	48.15	345	1.05	5712	5 0 .		
24	58.38	417	1.08	5860	M 0 5 3 2 5 6 . _ M _ _ _ _ 1 . 1 A - -	37.5	90S
22	64.29	458	0.98	4980	6 3 .		
19	73.95	526	0.85	3570	7 1 .		
55	25.51	184	3.39	7200	M 0 6 2 2 2 2 . _ M _ _ _ _ 1 . 1 A - -	41.5	90S
52	27.24	196	3.18	7200	2 8 .		
42	33.8	244	2.56	7200	3 2 .		
35	39.86	286	2.18	7200	3 6 .		
32	43.64	314	1.99	7200	4 5 .		
26	53.49	383	1.37	7200	5 0 .		
24	59.61	428	1.1	7200	5 6 .		

NOTE

Other output speeds are available using 2 and 8 pole motors - Consult Application Engineering

SERIES M

SELECTION TABLES

GEARED MOTORS

1.1 kW

4 POLE

N2 R/MIN	i	M2 Nm	Fm	N	Unit Designation	Kg	Motor Size
Output Speed	Ratio	Output Torque	Service Factor	Overhung Load	Column Entry [1] Through [20] Spaces to be filled when entering order	Weight	
20	72.28	513	1.22	7200	M 0 6 3 2 6 3 . _ M _ _ _ _ _ 1 . 1 A - -	42.5	90S
18	79.6	568	1.1	7200	7 1 .		
15	91.56	649	0.96	7200	8 0 .		
14	99.54	708	0.88	7200	1 0 0		
44	32.12	231	3.63	9517	M 0 7 2 2 3 2 . _ M _ _ _ _ _ 1 . 1 A - -	48.5	90S
40	35.17	252	3.35	9379	3 6 .		
33	42.21	302	2.86	9338	4 5 .		
29	48.56	347	2.02	9397	5 0 .		
26	53.96	385	1.55	10000	5 6 .		
24	58.95	420	1.79	8510	M 0 7 3 2 5 6 . _ M _ _ _ _ _ 1 . 1 A - -	53.5	90S
22	62.83	446	1.72	8210	6 3 .		
19	74.47	529	1.54	8500	7 1 .		
18	79.51	564	1.48	8043	8 0 .		
14	98.66	701	1.24	6317	1 0 0		
12	116.34	825	1.05	5740	1 1 2		
11	127.39	900	0.96	4490	1 2 5		
25	55.8	399	3.85	20000	M 0 8 2 2 5 6 . _ M _ _ _ _ _ 1 . 1 A - -	81.5	90S
23	60.33	427	3.74	20000	M 0 8 3 2 5 6 . _ M _ _ _ _ _ 1 . 1 A - -	81.5	90S
21	66.02	470	3.51	20000	6 3 .		
19	74.69	530	3.11	20000	7 1 .		
17	84.31	598	2.76	20000	8 0 .		
14	102.2	726	2.27	18631	1 0 0		
12	119.19	844	1.95	18177	1 1 2		
11	130.92	928	1.78	17391	1 2 5		
8.8	160.45	1138	1.45	18378	1 6 0		
8	175.21	1244	1.33	17221	1 8 0		
7	201.75	1424	1.16	15194	2 0 0		
6.2	228.91	1588	0.86	18916	M 0 8 4 2 2 2 5 _ M _ _ _ _ _ 1 . 1 A - -	112.5	90S
5.4	258.98	1795	0.82	17870	2 5 0		
15	93.92	669	3.94	29600	M 0 9 3 1 9 0 . _ M _ _ _ _ _ 1 . 1 A - -	131.5	90S
14	103.68	739	3.57	29600	1 0 0		
12	116.55	831	3.44	29500	1 1 2		
11	128.66	919	3.11	29500	1 2 5		
10	145.2	1031	2.4	29413	1 4 0		
8.8	160.29	1135	2.17	29397	1 6 0		
6.1	231.06	1621	1.63	25710	M 0 9 4 1 2 2 5 _ M _ _ _ _ _ 1 . 1 A - -	156.5	90S
5.5	258.09	1808	1.58	24951	2 5 0		
4.7	300.18	2103	1.36	24951	2 8 0		
4.2	335.85	2349	1.22	24951	3 0 0		
3.9	357.95	2506	1.14	24951	3 6 0		
3.3	424.23	2968	0.96	24951	4 0 0		
3	471.32	3293	0.87	24951	4 5 0		
2.8	503.22	3514	0.81	24951	5 0 0		
9	156.57	1109	3.76	49600	M 1 0 3 1 1 6 0 _ M _ _ _ _ _ 1 . 1 A - -	179.5	90S
6.4	220.22	1536	2.87	41580	M 1 0 4 1 2 2 5 _ M _ _ _ _ _ 1 . 1 A - -	217.5	90S
5.8	242.24	1689	2.61	41580	2 5 0		
5.1	278.36	1940	2.27	41580	2 8 0		
4.5	315.65	2198	2.01	41580	3 0 0		
4	348.16	2426	1.82	41580	3 6 0		
3.5	398.71	2776	1.59	41580	4 0 0		
3.2	443.06	3081	1.43	41580	4 5 0		
2.8	500.94	3481	1.27	41580	5 0 0		
2.4	580.78	4033	1.09	41580	6 5 0		
2	692.72	4804	0.92	41580	7 3 0		
5.6	249.68	1737	3.65	64632	M 1 3 4 1 2 5 0 _ M _ _ _ _ _ 1 . 1 A - -	292.5	90S
4.9	286.9	1995	3.18	64632	2 8 0		
4.3	325.33	2260	2.81	64632	3 0 0		
3.9	358.84	2494	2.55	64632	3 6 0		
3.4	410.95	2854	2.22	64632	4 0 0		
3	463.22	3216	1.97	64632	4 5 0		
2.7	523.74	3633	1.75	64632	5 0 0		
2.3	607.22	4209	1.51	64632	6 5 0		
1.9	724.25	5013	1.27	64632	7 3 0		
1.6	858.69	5911	1.07	64632	8 6 0		
1.4	1024.19	7043	0.9	64632	1 0 C		
1.2	1140.7	7829	0.81	64632	1 1 C		
3.6	390.06	2713	3.91	80613	M 1 4 4 1 3 6 0 _ M _ _ _ _ _ 1 . 1 A - -	408.5	90S
3.2	446.71	3105	3.41	80613	4 0 0		
2.9	492.49	3420	3.15	80613	4 5 0		
2.5	556.83	3864	2.79	80613	5 0 0		
2.2	645.58	4475	2.41	80613	6 5 0		
1.8	770.01	5330	2.02	80613	7 3 0		
1.8	801.52	5534	1.93	80613	8 6 0		
1.5	929.27	6410	1.66	80613	1 0 C		
1.3	1108.37	7636	1.4	80613	1 1 C		
1.2	1213.79	8356	1.28	80613	1 3 C		
0.94	1502.21	10314	0.98	80711	1 5 C		
0.78	1802.65	12351	0.82	80711	1 8 C		

NOTE

Other output speeds are available using 2 and 8 pole motors - Consult Application Engineering

SERIES M

SELECTION TABLES

GEARED MOTORS

1.1 kW

6 POLE

N2 R/MIN	i	M2 Nm	Fm	N	Unit Designation	Kg	Motor Size
Output Speed	Ratio	Output Torque	Service Factor	Overhung Load	Column Entry <input type="text" value="1"/> Through <input type="text" value="20"/> Spaces to be filled when entering order	Weight	
247	3.75	41	1.66	1500	M 0 1 2 2 3 . 6 _ M _ _ _ _ 1 . 1 C - -	24.5	90L
183	5.07	55	1.36	1490	5 . 0		
161	5.76	63	1.24	1480	5 . 6		
142	6.53	72	1.11	1490	6 . 3		
111	8.35	91	0.93	1490	8 . 0		
103	9	98	0.88	1380	9 . 0		
258	3.59	39	2.92	4000	M 0 2 2 2 3 . 6 _ M _ _ _ _ 1 . 1 C - -	27.5	90L
184	5.03	55	2.37	4000	5 . 0		
167	5.55	61	2.19	4000	5 . 6		
147	6.3	69	1.99	4000	6 . 3		
116	8	88	1.65	4000	8 . 0		
102	9.09	100	1.5	4000	9 . 0		
83	11.15	123	1.28	4000	1 1 .		
75	12.37	136	1.17	4000	1 2 .		
66	14.05	154	1.03	4000	1 4 .		
58	15.97	175	0.91	4000	1 6 .		
53	17.58	193	0.83	3680	1 8 .		
258	3.59	39	3.4	4000	M 0 3 2 2 3 . 6 _ M _ _ _ _ 1 . 1 C - -	27.5	90L
184	5.03	55	2.77	4000	5 . 0		
167	5.55	61	2.6	4000	5 . 6		
147	6.3	69	2.4	4000	6 . 3		
116	8	88	2.07	4000	8 . 0		
102	9.09	99	1.9	4000	9 . 0		
83	11.15	122	1.66	4000	1 1 .		
75	12.37	136	1.53	4000	1 2 .		
66	14.05	154	1.35	4000	1 4 .		
58	15.97	175	1.19	4000	1 6 .		
53	17.58	193	1.08	3680	1 8 .		
46	20.23	222	0.94	2880	2 0 .		
42	21.99	241	0.87	2340	2 2 .		
74	12.54	137	2.36	6370	M 0 4 2 2 1 2 . _ M _ _ _ _ 1 . 1 C - -	36.5	90L
63	14.58	160	2.1	6624	1 4 .		
57	16.31	179	1.88	6815	1 6 .		
53	17.39	191	1.76	6790	1 8 .		
45	20.61	226	1.49	6640	2 0 .		
42	22	242	1.39	6416	2 2 .		
34	27.3	299	1.13	5253	2 8 .		
29	32.19	354	0.95	5720	3 2 .		
26	35.25	386	0.87	5074	3 6 .		
74	12.54	138	3.08	5876	M 0 5 2 2 1 2 . _ M _ _ _ _ 1 . 1 C - -	37.5	90L
63	14.58	161	2.79	6072	1 4 .		
57	16.31	179	2.51	6216	1 6 .		
53	17.39	191	2.35	6477	1 8 .		
45	20.61	227	1.98	6346	2 0 .		
42	22	242	1.86	6103	2 2 .		
34	27.3	300	1.5	5173	2 8 .		
29	32.19	354	1.27	4327	3 2 .		
26	35.25	386	1.17	4327	3 6 .		
21	43.2	473	0.86	3343	4 5 .		
51	18.05	199	3	7200	M 0 6 2 2 1 6 . _ M _ _ _ _ 1 . 1 C - -	42.5	90L
46	20.2	222	2.81	7200	1 8 .		
43	21.53	237	2.64	7200	2 0 .		
36	25.51	281	2.22	7200	2 2 .		
34	27.24	300	2.08	7200	2 8 .		
27	33.8	372	1.68	7200	3 2 .		
23	39.86	438	1.43	6680	3 6 .		
21	43.64	479	1.31	6136	4 5 .		
17	53.49	585	0.93	7182	5 0 .		

NOTE

Other output speeds are available using 2 and 8 pole motors - Consult Application Engineering

SERIES M

SELECTION TABLES

GEARED MOTORS

1.1 kW

6 POLE

N2 R/MIN	i	M2 Nm	Fm	N	Unit Designation	Kg	Motor Size
Output Speed	Ratio	Output Torque	Service Factor	Overhung Load	Column Entry [1] Through [20] Spaces to be filled when entering order	Weight	
45	20.54	225	3.71	8987	M 0 7 2 2 2 0 . _ M _ _ _ _ _ 1 . 1 C - -	49.5	90L
40	23.23	255	3.32	8888	2 2 .		
34	26.93	295	2.91	8888	2 8 .		
29	32.12	352	2.46	8405	3 2 .		
26	35.17	385	2.25	8405	3 6 .		
22	42.21	460	1.88	7755	4 5 .		
19	48.56	529	1.32	7370	5 0 .		
17	53.96	586	1.02	7823	5 6 .		
16	58.95	641	1.35	6840	M 0 7 3 2 5 6 . _ M _ _ _ _ _ 1 . 1 C - -	54.5	90L
15	62.83	683	1.27	6240	6 3 .		
12	74.47	812	1.07	4470	7 1 .		
12	79.51	861	1.01	3701	8 0 .		
9.4	98.66	1070	0.81	3539	1 0 0		
21	44.38	486	3.39	20000	M 0 8 2 2 4 5 . _ M _ _ _ _ _ 1 . 1 C - -	82.5	90L
19	48.46	530	3.11	20000	5 0 .		
17	55.8	608	2.55	18720	5 6 .		
15	60.33	654	2.52	20000	M 0 8 3 2 5 6 . _ M _ _ _ _ _ 1 . 1 C - -	82.5	90L
14	66.02	716	2.3	18126	6 3 .		
12	74.69	811	2.03	17846	7 1 .		
11	84.31	914	1.8	17539	8 0 .		
9.1	102.2	1108	1.49	15510	1 0 0		
7.8	119.19	1290	1.28	14323	1 1 2		
7.1	130.92	1416	1.17	13333	1 2 5		
5.8	160.45	1744	0.95	11871	1 6 0		
5.3	175.21	1895	0.87	10117	1 8 0		
15	61.13	669	3.69	29600	M 0 9 2 1 6 3 . _ M _ _ _ _ _ 1 . 1 C - -	123.5	90L
13	68.74	751	3.23	29600	7 1 .		
11	82.51	899	3.18	29500	M 0 9 3 1 8 0 . _ M _ _ _ _ _ 1 . 1 C - -	132.5	90L
10	93.92	1021	2.58	29400	9 0 .		
8.9	103.68	1128	2.34	29300	1 0 0		
7.9	116.55	1270	2.25	29282	1 1 2		
7.2	128.66	1401	2.04	29258	1 2 5		
6.4	145.2	1575	1.57	29166	1 4 0		
5.8	160.29	1740	1.42	29033	1 6 0		
4	231.06	2475	1.07	25710	M 0 9 4 1 2 2 5 _ M _ _ _ _ _ 1 . 1 C - -	157.5	90L
3.6	258.09	2761	1.03	24951	2 5 0		
3.1	300.18	3209	0.89	24951	2 8 0		
7.1	129.94	1410	3.13	49100	M 1 0 3 1 1 2 5 _ M _ _ _ _ _ 1 . 1 C - -	180.5	90L
6.8	135.88	1473	2.83	49100	1 4 0		
5.9	156.57	1694	2.46	48700	1 6 0		
4.2	220.22	2346	1.88	41580	M 1 0 4 1 2 2 5 _ M _ _ _ _ _ 1 . 1 C - -	218.5	90L
3.8	242.24	2580	1.71	41580	2 5 0		
3.3	278.36	2963	1.49	41580	2 8 0		
2.9	315.65	3355	1.32	41580	3 0 0		
2.7	348.16	3702	1.19	41580	3 6 0		
2.3	398.71	4237	1.04	41580	4 0 0		
2.1	443.06	4703	0.94	41580	4 5 0		
1.8	500.94	5312	0.83	41580	5 0 0		
4.1	226.98	2411	2.63	64632	M 1 3 4 1 2 2 5 _ M _ _ _ _ _ 1 . 1 C - -	293.5	90L
3.7	249.68	2652	2.39	64632	2 5 0		
3.2	286.9	3045	2.08	64632	2 8 0		
2.8	325.33	3448	1.84	64632	3 0 0		
2.6	358.84	3805	1.67	64632	3 6 0		
2.3	410.95	4354	1.46	64632	4 0 0		
2	463.22	4906	1.29	64632	4 5 0		
1.8	523.74	5542	1.15	64632	5 0 0		
1.5	607.22	6418	0.99	64632	6 5 0		
1.3	724.25	7643	0.83	64632	7 3 0		
3.4	271.4	2884	3.67	80613	M 1 4 4 1 2 5 0 _ M _ _ _ _ _ 1 . 1 C - -	409.5	90L
3	311.86	3311	3.2	80613	2 8 0		
2.6	353.64	3749	2.83	80613	3 0 0		
2.4	390.06	4137	2.56	80613	3 6 0		
2.1	446.71	4734	2.24	80613	4 0 0		
1.9	492.49	5215	2.07	80613	4 5 0		
1.7	556.83	5891	1.83	80613	5 0 0		
1.4	645.58	6822	1.58	80613	6 5 0		
1.2	770.01	8123	1.33	80613	7 3 0		
1.2	801.52	8442	1.26	80613	8 6 0		
0	929.27	9777	1.09	80613	1 0 C		
0.83	1108.37	11643	0.92	80613	1 1 C		
0.76	1213.79	12739	0.84	80613	1 3 C		

NOTE

Other output speeds are available using 2 and 8 pole motors - Consult Application Engineering

SERIES M

SELECTION TABLES

GEARED MOTORS

1.5 kW

4 POLE

N2 R/MIN	i	M2 Nm	Fm	N	Unit Designation	Kg	Motor Size
Output Speed	Ratio	Output Torque	Service Factor	Overhung Load	Column Entry [1] Through [20] Spaces to be filled when entering order	Weight	
379	3.75	36	1.63	1484	M 0 1 2 2 3 . 6 _ M _ _ _ _ 1 . 5 A _ _	24.5	90L
280	5.07	49	1.36	1517	5 . 0		
246	5.76	56	1.27	1521	5 . 6		
218	6.53	63	1.18	1340	6 . 3		
170	8.35	81	0.97	1280	8 . 0		
158	9	88	0.91	1270	9 . 0		
396	3.59	34	2.87	3728	M 0 2 2 2 3 . 6 _ M _ _ _ _ 1 . 5 A _ _	27.5	90L
282	5.03	49	2.36	3917	5 . 0		
256	5.55	54	2.23	3967	5 . 6		
225	6.3	61	2.06	3984	6 . 3		
178	8	78	1.74	4000	8 . 0		
156	9.09	88	1.57	4000	9 . 0		
127	11.15	108	1.33	4000	1 1 .		
115	12.37	120	1.23	4000	1 2 .		
101	14.05	137	1.12	4000	1 4 .		
89	15.97	156	1.03	3850	1 6 .		
81	17.58	171	0.93	3640	1 8 .		
70	20.23	197	0.81	3280	2 0 .		
396	3.59	34	3.38	3690	M 0 3 2 2 3 . 6 _ M _ _ _ _ 1 . 5 A _ _	27.5	90L
282	5.03	48	2.76	3698	5 . 0		
256	5.55	54	2.59	3948	5 . 6		
225	6.3	61	2.4	3982	6 . 3		
178	8	78	2.06	4000	8 . 0		
156	9.09	89	1.89	4000	9 . 0		
127	11.15	108	1.65	4000	1 1 .		
115	12.37	120	1.54	4000	1 2 .		
101	14.05	137	1.41	4000	1 4 .		
89	15.97	155	1.32	3901	1 6 .		
81	17.58	171	1.21	3764	1 8 .		
70	20.23	197	1.06	3280	2 0 .		
65	21.99	214	0.97	3000	2 2 .		
54	26.4	256	0.82	1789	2 8 .		
113	12.54	122	2.31	5611	M 0 4 2 2 1 2 . _ M _ _ _ _ 1 . 5 A _ _	36.5	90L
97	14.58	142	2.07	5814	1 4 .		
87	16.31	159	1.92	5915	1 6 .		
82	17.39	170	1.83	6000	1 8 .		
69	20.61	201	1.59	6240	2 0 .		
65	22	215	1.5	6333	2 2 .		
52	27.3	265	1.26	6499	2 8 .		
44	32.19	313	1.08	6840	3 2 .		
40	35.25	342	0.99	6950	3 6 .		
33	43.2	420	0.8	6110	4 5 .		
113	12.54	122	3.47	5158	M 0 5 2 2 1 2 . _ M _ _ _ _ 1 . 5 A _ _	37.5	90L
97	14.58	143	3.15	5238	1 4 .		
87	16.31	159	2.82	5630	1 6 .		
82	17.39	170	2.64	5710	1 8 .		
69	20.61	201	2.23	5869	2 0 .		
65	22	215	2.09	5651	2 2 .		
52	27.3	267	1.68	5575	2 8 .		
44	32.19	314	1.43	5658	3 2 .		
40	35.25	342	1.31	5153	3 6 .		
33	43.2	420	0.84	5610	4 5 .		
79	18.05	176	3.37	7200	M 0 6 2 2 1 6 . _ M _ _ _ _ 1 . 5 A _ _	42.5	90L
70	20.2	197	3.17	7200	1 8 .		
66	21.53	210	2.97	7200	2 0 .		
56	25.51	249	2.51	7200	2 2 .		
52	27.24	266	2.35	7200	2 8 .		
42	33.8	330	1.89	7200	3 2 .		
36	39.86	388	1.61	7200	3 6 .		
33	43.64	426	1.47	7200	4 5 .		
27	53.49	519	1.01	7200	5 0 .		
24	59.61	580	0.81	7200	5 6 .		
20	72.28	694	0.9	7200	M 0 6 3 2 6 3 . _ M _ _ _ _ 1 . 5 A _ _	43.5	90L

NOTE

Other output speeds are available using 2 and 8 pole motors - Consult Application Engineering

SERIES M

SELECTION TABLES

GEARED MOTORS

1.5 kW

4 POLE

N2 R/MIN	i	M2 Nm	Fm	N	Unit Designation	Kg	Motor Size
Output Speed	Ratio	Output Torque	Service Factor	Overhung Load	Column Entry [1] Through [20] Spaces to be filled when entering order	Weight	
61	23.23	226	3.59	9013	M 0 7 2 2 2 2 . _ M _ _ _ _ _ 1 . 5 A - -	49.5	90L
53	26.93	262	3.14	8800	2 8 .		
44	32.12	313	2.68	8966	3 2 .		
40	35.17	342	2.47	8670	3 6 .		
34	42.21	409	2.11	8583	4 5 .		
29	48.56	470	1.49	8708	5 0 .		
26	53.96	521	1.14	10000	5 6 .		
24	58.95	568	1.33	7426	M 0 7 3 2 5 6 . _ M _ _ _ _ _ 1 . 5 A - -	54.5	90L
23	62.83	604	1.27	6908	6 3 .		
19	74.47	717	1.14	7410	7 1 .		
18	79.51	764	1.09	6620	8 0 .		
14	98.66	949	0.91	3640	1 0 0		
32	44.38	432	3.82	20000	M 0 8 2 2 4 5 . _ M _ _ _ _ _ 1 . 5 A - -	82.5	90L
29	48.46	471	3.5	20000	5 0 .		
25	55.8	541	2.85	19737	5 6 .		
24	60.33	579	2.76	19600	M 0 8 3 2 5 6 . _ M _ _ _ _ _ 1 . 5 A - -	82.5	90L
22	66.02	636	2.59	19310	6 3 .		
19	74.69	717	2.3	18882	7 1 .		
17	84.31	810	2.04	19178	8 0 .		
14	102.2	983	1.68	17066	1 0 0		
12	119.19	1143	1.44	16851	1 1 2		
11	130.92	1257	1.31	15494	1 2 5		
8.9	160.45	1541	1.07	17200	1 6 0		
8.1	175.21	1684	0.98	15200	1 8 0		
7	201.75	1929	0.86	11700	2 0 0		
26	55.18	536	3.75	29700	M 0 9 2 1 5 6 . _ M _ _ _ _ _ 1 . 5 A - -	123.5	90L
21	68.74	668	3.7	29600	7 1 .		
17	82.51	797	3.58	29600	M 0 9 3 1 8 0 . _ M _ _ _ _ _ 1 . 5 A - -	132.5	90L
15	93.92	906	2.91	29462	9 0 .		
14	103.68	1000	2.64	29434	1 0 0		
12	116.55	1126	2.54	29348	1 1 2		
11	128.66	1244	2.3	29320	1 2 5		
10	145.2	1396	1.77	29200	1 4 0		
8.9	160.29	1537	1.61	29166	1 6 0		
6.1	231.06	2195	1.2	25710	M 0 9 4 1 2 2 5 _ M _ _ _ _ _ 1 . 5 A - -	157.5	90L
5.5	258.09	2449	1.17	24951	2 5 0		
4.7	300.18	2847	1	24951	2 8 0		
4.2	335.85	3181	0.9	24951	3 0 0		
4	357.95	3393	0.84	24951	3 6 0		
13	109.97	1059	3.56	49600	M 1 0 3 1 1 0 0 _ M _ _ _ _ _ 1 . 5 A - -	180.5	90L
11	129.94	1250	3.53	49300	1 2 5		
10	135.88	1303	3.19	49300	1 4 0		
9.1	156.57	1502	2.77	48965	1 6 0		
6.4	220.22	2080	2.12	41580	M 1 0 4 1 2 2 5 _ M _ _ _ _ _ 1 . 5 A - -	218.5	90L
5.9	242.24	2287	1.93	41580	2 5 0		
5.1	278.36	2628	1.68	41580	2 8 0		
4.5	315.65	2976	1.48	41580	3 0 0		
4.1	348.16	3284	1.34	41580	3 6 0		
3.6	398.71	3760	1.17	41580	4 0 0		
3.2	443.06	4172	1.06	41580	4 5 0		
2.8	500.94	4714	0.94	41580	5 0 0		
2.4	580.78	5461	0.81	41580	6 5 0		
6.3	226.98	2139	2.97	64632	M 1 3 4 1 2 2 5 _ M _ _ _ _ _ 1 . 5 A - -	293.5	90L
5.7	249.68	2352	2.7	64632	2 5 0		
4.9	286.9	2702	2.35	64632	2 8 0		
4.4	325.33	3060	2.07	64632	3 0 0		
4	358.84	3377	1.88	64632	3 6 0		
3.5	410.95	3865	1.64	64632	4 0 0		
3.1	463.22	4355	1.46	64632	4 5 0		
2.7	523.74	4920	1.29	64632	5 0 0		
2.3	607.22	5699	1.11	64632	6 5 0		
2	724.25	6788	0.94	64632	7 3 0		
4.6	311.86	2940	3.6	80613	M 1 4 4 1 2 8 0 _ M _ _ _ _ _ 1 . 5 A - -	409.5	90L
4	353.64	3329	3.18	80613	3 0 0		
3.6	390.06	3673	2.88	80613	3 6 0		
3.2	446.71	4204	2.52	80613	4 0 0		
2.9	492.49	4631	2.33	80613	4 5 0		
2.6	556.83	5232	2.06	80613	5 0 0		
2.2	645.58	6059	1.78	80613	6 5 0		
1.8	770.01	7217	1.49	80613	7 3 0		
1.8	801.52	7494	1.42	80613	8 6 0		
1.5	929.27	8680	1.23	80613	1 0 C		
1.3	1108.37	10340	1.03	80613	1 1 C		
1.2	1213.79	11314	0.94	80613	1 3 C		

NOTE

Other output speeds are available using 2 and 8 pole motors - Consult Application Engineering

SERIES M

SELECTION TABLES

GEARED MOTORS

1.5 kW

6 POLE

N2 R/MIN	i	M2 Nm	Fm	N	Unit Designation	Kg	Motor Size
Output Speed	Ratio	Output Torque	Service Factor	Overhung Load	Column Entry <input type="text" value="1"/> Through <input type="text" value="20"/> Spaces to be filled when entering order	Weight	
251	3.75	56	1.21	980	M 0 1 2 2 3 . 6 _ M _ _ _ _ 1 . 5 C - -	36	100L
186	5.07	76	1.00	980	5 . 0		
163	5.76	86	0.91	980	5 . 6		
144	6.53	97	0.82	980	6 . 3		
262	3.59	54	2.15	3100	M 0 2 2 2 3 . 6 _ M _ _ _ _ 1 . 5 C - -	39	100L
187	5.03	75	1.74	3100	5 . 0		
169	5.55	83	1.62	3100	5 . 6		
149	6.30	94	1.47	3100	6 . 3		
118	8.00	119	1.21	3100	8 . 0		
103	9.09	136	1.11	3100	9 . 0		
84	11.15	167	0.95	2600	1 1 .		
76	12.37	185	0.87	2300	1 2 .		
262	3.59	54	2.50	2300	M 0 3 2 2 3 . 6 _ M _ _ _ _ 1 . 5 C - -	39	100L
187	5.03	75	2.04	2300	5 . 0		
169	5.55	83	1.92	2300	5 . 6		
149	6.30	94	1.78	2300	6 . 3		
118	8.00	119	1.52	2300	8 . 0		
103	9.09	136	1.40	2300	9 . 0		
84	11.15	167	1.22	2300	1 1 .		
76	12.37	185	1.13	2300	1 2 .		
67	14.05	210	1.00	2300	1 4 .		
59	15.97	238	0.88	2050	1 6 .		
53	17.58	263	0.80	1900	1 8 .		
184	5.04	75	3.59	5180	M 0 4 2 2 5 . 0 _ M _ _ _ _ 1 . 5 C - -	49	100L
164	5.65	85	3.36	5270	5 . 6		
146	6.34	95	3.08	5360	6 . 3		
115	8.05	120	2.56	5530	8 . 0		
101	9.13	137	2.32	5670	9 . 0		
85	10.89	163	2.04	5920	1 1 .		
74	12.54	188	1.73	6119	1 2 .		
63	14.58	219	1.54	6331	1 4 .		
57	16.31	244	1.38	6489	1 6 .		
53	17.39	261	1.29	6491	1 8 .		
45	20.61	309	1.09	6232	2 0 .		
42	22	330	1.02	5846	2 2 .		
34	27.3	407	0.83	4186	2 8 .		
115	8.05	121	3.71	5060	M 0 5 2 2 8 . 0 _ M _ _ _ _ 1 . 5 C - -	49	100L
101	9.13	137	3.27	5460	9 . 0		
85	10.89	164	2.74	5700	1 1 .		
74	12.54	188	2.26	5732	1 2 .		
63	14.58	219	2.05	5904	1 4 .		
57	16.31	244	1.84	6028	1 6 .		
53	17.39	261	1.72	6212	1 8 .		
45	20.61	309	1.45	5878	2 0 .		
42	22	330	1.36	5501	2 2 .		
34	27.3	409	1.1	4063	2 8 .		
29	32.19	483	0.93	2754	3 2 .		
26	35.25	526	0.85	2754	3 6 .		

NOTE

Other output speeds are available using 2 and 8 pole motors - Consult Application Engineering

SERIES M

SELECTION TABLES

GEARED MOTORS

1.5 kW

6 POLE

N2 R/MIN	i	M2 Nm	Fm	N	Unit Designation	Kg	Motor Size
Output Speed	Ratio	Output Torque	Service Factor	Overhung Load	Column Entry <input type="text" value="1"/> Through <input type="text" value="20"/> Spaces to be filled when entering order	Weight	
69	13.48	203	3.08	7200	M 0 6 2 2 1 2 . _ M _ _ _ _ 1 . 5 C - -	54	100L
60	15.52	233	2.26	7200	1 4 .		
51	18.05	271	2.2	7200	1 6 .		
46	20.2	303	2.06	7200	1 8 .		
43	21.53	323	1.93	7200	2 0 .		
36	25.51	383	1.63	7200	2 2 .		
34	27.24	409	1.53	7200	2 8 .		
27	33.8	507	1.23	7200	3 2 .		
23	39.86	597	1.05	6301	3 6 .		
21	43.64	654	0.96	5363	4 5 .		
64	14.34	215	3.75	8921	M 0 7 2 2 1 4 . _ M _ _ _ _ 1 . 5 C - -	62	100L
57	16.26	243	3.35	8727	1 6 .		
52	17.94	269	3.06	8543	1 8 .		
45	20.54	308	2.72	8251	2 0 .		
40	23.23	347	2.43	8080	2 2 .		
34	26.93	403	2.13	8080	2 8 .		
29	32.12	480	1.81	7246	3 2 .		
26	35.17	525	1.65	7246	3 6 .		
22	42.21	628	1.38	6122	4 5 .		
19	48.56	722	0.97	5457	5 0 .		
16	58.95	874	0.99	5110	M 0 7 3 2 5 6 . _ M _ _ _ _ 1 . 5 C - -	66	100L
15	62.83	931	0.93	4180	6 3 .		
28	32.97	493	3.35	20000	M 0 8 2 2 3 2 . _ M _ _ _ _ 1 . 5 C - -	94	100L
26	36.21	541	3.04	20000	3 6 .		
21	44.38	663	2.49	18642	4 5 .		
19	48.46	723	2.28	18360	5 0 .		
17	55.8	829	1.87	17258	5 6 .		
15	60.33	891	1.85	18038	M 0 8 3 2 5 6 . _ M _ _ _ _ 1 . 5 C - -	95	100L
14	66.02	976	1.69	15984	6 3 .		
12	74.69	1107	1.49	15384	7 1 .		
11	84.31	1246	1.32	14726	8 0 .		
9.1	102.2	1510	1.09	12244	1 0 0		
7.8	119.19	1759	0.94	10194	1 1 2		
7.1	130.92	1931	0.85	8484	1 2 5		
17	55.18	822	2.37	29600	M 0 9 2 1 5 6 . _ M _ _ _ _ 1 . 5 C - -	135	100L
15	61.13	913	2.7	29472	6 3 .		
13	68.74	1025	2.37	29372	7 1 .		
15	59.85	889	2.97	29500	M 0 9 3 1 5 6 . _ M _ _ _ _ 1 . 5 C - -	144	100L
14	66.49	987	2.67	29400	6 3 .		
12	74.26	1104	2.59	29400	7 1 .		
11	82.51	1226	2.33	29318	8 0 .		
10	93.92	1393	1.89	29181	9 0 .		
8.9	103.68	1539	1.72	29081	1 0 0		
7.9	116.55	1732	1.65	29034	1 1 2		
7.2	128.66	1910	1.5	28982	1 2 5		
6.4	145.2	2148	1.15	28851	1 4 0		
5.8	160.29	2373	1.04	28693	1 6 0		

NOTE

Other output speeds are available using 2 and 8 pole motors - Consult Application Engineering

SERIES M

SELECTION TABLES

GEARED MOTORS

1.5 kW

6 POLE

N2 R/MIN	i	M2 Nm	Fm	N	Unit Designation	Kg	Motor Size
Output Speed	Ratio	Output Torque	Service Factor	Overhung Load	Column Entry [1] Through [20] Spaces to be filled when entering order	Weight	
10	95.44	1414	2.67	49000	M 1 0 3 1 9 0 . _ M _ _ _ _ 1 . 5 C - -	193	100L
8.4	109.97	1630	2.31	48700	1 0 0		
8.2	112.77	1670	2.64	48700	1 1 2		
7.1	129.94	1923	2.29	48200	1 2 5		
6.8	135.88	2009	2.07	48136	1 4 0		
5.9	156.57	2310	1.81	47734	1 6 0		
4.2	220.22	3199	1.38	41580	M 1 0 4 1 2 2 5 _ M _ _ _ _ 1 . 5 C - -	230	100L
3.8	242.24	3518	1.25	41580	2 5 0		
3.3	278.36	4040	1.09	41580	2 8 0		
2.9	315.65	4575	0.96	41580	3 0 0		
2.7	348.16	5049	0.87	41580	3 6 0		
7.3	126.62	1858	3.42	66800	M 1 3 3 1 1 2 5 _ M _ _ _ _ 1 . 5 C - -	263	100L
6.7	139.07	2035	3.17	66700	1 4 0		
6	154.89	2265	2.85	66700	1 6 0		
5.3	173.37	2547	2.49	66600	1 8 0		
5	184.46	2715	2.34	66500	2 0 0		
4.4	212.09	3113	2.07	66400	2 2 5		
4.1	226.98	3288	1.93	64632	M 1 3 4 1 2 2 5 _ M _ _ _ _ 1 . 5 C - -	305	100L
3.7	249.68	3616	1.76	64632	2 5 0		
3.2	286.9	4153	1.53	64632	2 8 0		
2.8	325.33	4702	1.35	64632	3 0 0		
2.6	358.84	5188	1.22	64632	3 6 0		
2.3	410.95	5937	1.07	64632	4 0 0		
2	463.22	6691	0.95	64632	4 5 0		
1.8	523.74	7558	0.84	64632	5 0 0		
4.4	211.96	3101	3.26	80900	M 1 4 3 1 2 2 5 _ M _ _ _ _ 1 . 5 C - -	392	100L
3.7	246.73	3576	2.96	80613	M 1 4 4 1 2 2 5 _ M _ _ _ _ 1 . 5 C - -	421	100L
3.4	271.4	3932	2.69	80613	2 5 0		
3	311.86	4516	2.35	80613	2 8 0		
2.6	353.64	5112	2.07	80613	3 0 0		
2.4	390.06	5641	1.88	80613	3 6 0		
2.1	446.71	6455	1.64	80613	4 0 0		
1.9	492.49	7112	1.51	80613	4 5 0		
1.7	556.83	8034	1.34	80613	5 0 0		
1.4	645.58	9302	1.16	80613	6 5 0		
1.2	770.01	11077	0.97	80613	7 3 0		
1.2	801.52	11512	0.93	80613	8 6 0		

NOTE

Other output speeds are available using 2 and 8 pole motors - Consult Application Engineering

SERIES M

SELECTION TABLES

GEARED MOTORS

2.2 kW

4 POLE

N2 R/MIN	i	M2 Nm	Fm	N	Unit Designation	Kg	Motor Size
Output Speed	Ratio	Output Torque	Service Factor	Overhung Load	Column Entry 1 Through 20 Spaces to be filled when entering order	Weight	
379	3.75	53	1.11	1380	M 0 1 2 2 3 . 6 _ M _ _ _ _ 2 . 2 A - -	30	100L
280	5.07	72	0.93	1380	5 . 0		
246	5.76	82	0.87	1360	5 . 6		
396	3.59	51	1.95	3690	M 0 2 2 2 3 . 6 _ M _ _ _ _ 2 . 2 A - -	33	100L
282	5.03	72	1.61	3660	5 . 0		
256	5.55	79	1.52	3910	5 . 6		
225	6.3	90	1.41	3970	6 . 3		
178	8	114	1.19	4000	8 . 0		
156	9.09	130	1.07	4000	9 . 0		
127	11.15	159	0.91	4000	1 1 .		
115	12.37	176	0.84	4000	1 2 .		
396	3.59	51	2.31	3690	M 0 3 2 2 3 . 6 _ M _ _ _ _ 2 . 2 A - -	33	100L
282	5.03	71	1.88	3660	5 . 0		
256	5.55	79	1.77	3910	5 . 6		
225	6.3	89	1.63	3970	6 . 3		
178	8	114	1.4	4000	8 . 0		
156	9.09	130	1.29	4000	9 . 0		
127	11.15	159	1.12	4000	1 1 .		
115	12.37	177	1.05	4000	1 2 .		
101	14.05	201	0.96	4000	1 4 .		
89	15.97	227	0.9	3850	1 6 .		
81	17.58	251	0.83	3640	1 8 .		
398	3.58	51	3.96	4526	M 0 4 2 2 3 . 6 _ M _ _ _ _ 2 . 2 A - -	49	100L
283	5.04	71	3.29	4718	5 . 0		
252	5.65	80	3.09	4800	5 . 6		
225	6.34	90	2.89	4881	6 . 3		
177	8.05	115	2.51	5024	8 . 0		
156	9.13	130	2.29	5095	9 . 0		
131	10.89	156	1.99	5179	1 1 .		
114	12.54	178	1.58	5420	1 2 .		
98	14.58	208	1.42	5594	1 4 .		
87	16.31	232	1.31	5539	1 6 .		
82	17.39	248	1.25	5598	1 8 .		
69	20.61	293	1.09	5764	2 0 .		
65	22	314	1.03	5822	2 2 .		
52	27.3	388	0.86	5983	2 8 .		
177	8.05	115	3.9	4843	M 0 5 2 2 8 . 0 _ M _ _ _ _ 2 . 2 A - -	49	100L
156	9.13	130	3.44	4915	9 . 0		
131	10.89	156	2.88	4998	1 1 .		
114	12.54	179	2.37	5016	1 2 .		
98	14.58	208	2.15	5016	1 4 .		
87	16.31	233	1.93	5431	1 6 .		
82	17.39	248	1.81	5497	1 8 .		
69	20.61	294	1.53	5567	2 0 .		
65	22	314	1.43	5113	2 2 .		
52	27.3	390	1.15	4504	2 8 .		
44	32.19	459	0.98	4522	3 2 .		
40	35.25	501	0.9	3645	3 6 .		
106	13.48	193	3.18	7200	M 0 6 2 2 1 2 . _ M _ _ _ _ 2 . 2 A - -	54	100L
92	15.52	222	2.37	7200	1 4 .		
79	18.05	258	2.31	7200	1 6 .		
71	20.2	288	2.17	7200	1 8 .		
66	21.53	307	2.03	7200	2 0 .		
56	25.51	364	1.72	7200	2 2 .		
52	27.24	389	1.61	7200	2 8 .		
42	33.8	483	1.3	7200	3 2 .		
36	39.86	567	1.1	7200	3 6 .		
33	43.64	622	1.01	7200	4 5 .		

NOTE

Other output speeds are available using 2 and 8 pole motors - Consult Application Engineering

SERIES M

SELECTION TABLES

GEARED MOTORS

2.2 kW

4 POLE

N2 R/MIN	i	M2 Nm	Fm	N	Unit Designation	Kg	Motor Size
Output Speed	Ratio	Output Torque	Service Factor	Overhung Load	Column Entry [1] Through [20] Spaces to be filled when entering order	Weight	
99	14.34	205	3.69	8331	M 0 7 2 2 1 4 . _ M _ _ _ _ 2 . 2 A - -	62	100L
88	16.26	232	3.39	8633	1 6 .		
79	17.94	256	3.1	9020	1 8 .		
69	20.54	293	2.74	8833	2 0 .		
61	23.23	330	2.46	8092	2 2 .		
53	26.93	383	2.15	7680	2 8 .		
44	32.12	457	1.84	8001	3 2 .		
41	35.17	500	1.69	7430	3 6 .		
34	42.21	598	1.44	7261	4 5 .		
29	48.56	687	1.02	7502	5 0 .		
24	58.95	834	0.9	5530	M 0 7 3 2 5 6 . _ M _ _ _ _ 2 . 2 A - -	60	100L
23	62.83	887	0.87	4630	6 3 .		
43	32.97	469	3.47	20190	M 0 8 2 2 3 2 . _ M _ _ _ _ 2 . 2 A - -	94	100L
39	36.21	515	3.2	20215	3 6 .		
32	44.38	631	2.61	18821	4 5 .		
29	48.46	689	2.39	18617	5 0 .		
26	55.8	790	1.95	19279	5 6 .		
24	60.33	846	1.89	18900	M 0 8 3 2 5 6 . _ M _ _ _ _ 2 . 2 A - -	95	100L
22	66.02	930	1.77	18103	6 3 .		
19	74.69	1049	1.57	16927	7 1 .		
17	84.31	1183	1.39	17742	8 0 .		
14	102.2	1437	1.15	14328	1 0 0		
12	119.19	1671	0.99	14531	1 1 2		
11	130.92	1837	0.9	12174	1 2 5		
32	44.44	634	3.89	29615	M 0 9 2 1 4 5 . _ M _ _ _ _ 2 . 2 A - -	135	100L
29	49.07	699	3.46	29617	5 0 .		
26	55.18	783	2.56	29563	5 6 .		
23	61.13	870	2.84	29546	6 3 .		
21	68.74	976	2.53	29429	7 1 .		
24	59.85	847	3.06	29523	M 0 9 3 1 5 6 . _ M _ _ _ _ 2 . 2 A - -	144	100L
21	66.49	939	2.81	29423	6 3 .		
19	74.26	1049	2.72	29429	7 1 .		
17	82.51	1166	2.45	29376	8 0 .		
15	93.92	1325	1.99	29220	9 0 .		
14	103.68	1462	1.8	29144	1 0 0		
12	116.55	1645	1.74	29082	1 1 2		
11	128.66	1818	1.57	29006	1 2 5		
10	145.2	2040	1.21	28826	1 4 0		
8.9	160.29	2247	1.1	28762	1 6 0		
18	79.08	1112	3.96	49582	M 1 0 3 1 8 0 . _ M _ _ _ _ 2 . 2 A - -	193	100L
15	95.44	1346	2.8	49101	9 0 .		
13	109.97	1548	2.43	48771	1 0 0		
13	112.77	1587	2.78	48771	1 1 2		
11	129.94	1828	2.41	48360	1 2 5		
10	135.88	1904	2.18	48326	1 4 0		
9.1	156.57	2196	1.9	47855	1 6 0		
6.5	220.22	3040	1.45	41580	M 1 0 4 1 2 2 5 _ M _ _ _ _ 2 . 2 A - -	230	100L
5.9	242.24	3343	1.32	41580	2 5 0		
5.1	278.36	3841	1.15	41580	2 8 0		
4.5	315.65	4349	1.01	41580	3 0 0		
4.1	348.16	4800	0.92	41580	3 6 0		
3.6	398.71	5495	0.8	41580	4 0 0		

NOTE

Other output speeds are available using 2 and 8 pole motors - Consult Application Engineering

SERIES M

SELECTION TABLES

GEARED MOTORS

2.2 kW

4 POLE

N2 R/MIN	i	M2 Nm	Fm	N	Unit Designation	Kg	Motor Size
Output Speed	Ratio	Output Torque	Service Factor	Overhung Load	Column Entry <input type="text" value="1"/> Through <input type="text" value="20"/> Spaces to be filled when entering order	Weight	
13	113.69	1588	4	66923	M 1 3 3 1 1 1 2 _ M _ _ _ _ 2 . 2 A - -	263	100L
11	126.62	1768	3.59	66826	1 2 5		
10	139.07	1935	3.34	66726	1 4 0		
9.2	154.89	2155	3	66730	1 6 0		
8.2	173.37	2425	2.62	66636	1 8 0		
7.7	184.46	2584	2.46	66536	2 0 0		
6.7	212.09	2957	2.18	66442	2 2 5		
6.3	226.98	3126	2.03	64632	M 1 3 4 1 2 2 5 _ M _ _ _ _ 2 . 2 A - -	305	100L
5.7	249.68	3438	1.85	64632	2 5 0		
5	286.9	3949	1.61	64632	2 8 0		
4.4	325.33	4472	1.42	64632	3 0 0		
4	358.84	4936	1.29	64632	3 6 0		
3.5	410.95	5649	1.12	64632	4 0 0		
3.1	463.22	6365	1	64632	4 5 0		
2.7	523.74	7191	0.88	64632	5 0 0		
6.8	208.15	2903	3.79	80900	M 1 4 3 1 2 0 0 _ M _ _ _ _ 2 . 2 A - -	392	100L
6.7	211.96	2951	3.42	80900	2 2 5		
5.8	246.73	3402	3.11	80613	M 1 4 4 1 2 2 5 _ M _ _ _ _ 2 . 2 A - -	421	100L
5.3	271.4	3741	2.83	80613	2 5 0		
4.6	311.86	4297	2.47	80613	2 8 0		
4	353.64	4865	2.18	80613	3 0 0		
3.7	390.06	5369	1.97	80613	3 6 0		
3.2	446.71	6145	1.72	80613	4 0 0		
2.9	492.49	6769	1.59	80613	4 5 0		
2.6	556.83	7647	1.41	80613	5 0 0		
2.2	645.58	8856	1.22	80613	6 5 0		
1.9	770.01	10548	1.02	80613	7 3 0		
1.8	801.52	10952	0.97	80613	8 6 0		
1.5	929.27	12686	0.84	80613	1 0 C		

NOTE

Other output speeds are available using 2 and 8 pole motors - Consult Application Engineering

SERIES M

SELECTION TABLES

GEARED MOTORS

2.2 kW

6 POLE

N2 R/MIN	i	M2 Nm	Fm	N	Unit Designation	Kg	Motor Size
Output Speed	Ratio	Output Torque	Service Factor	Overhung Load	Column Entry <input type="text" value="1"/> Through <input type="text" value="20"/> Spaces to be filled when entering order	Weight	
262	3.59	79	1.27	3100	M 0 2 2 2 3 . 6 _ M _ _ _ _ 2 . 2 C _ _	46	112M
187	5.03	110	1.05	3100	5 . 0		
169	5.55	121	1.00	3100	5 . 6		
149	6.30	138	0.92	2650	6 . 3		
262	3.59	79	1.50	2300	M 0 3 2 2 3 . 6 _ M _ _ _ _ 2 . 2 C _ _	46	112M
187	5.03	110	1.22	2300	5 . 0		
169	5.55	121	1.15	2300	5 . 6		
149	6.30	138	1.07	2300	6 . 3		
118	8.00	175	0.92	2150	8 . 0		
103	9.09	199	0.84	2000	9 . 0		
265	3.58	77	3.02	4780	M 0 4 2 2 3 . 6 _ M _ _ _ _ 2 . 2 C _ _	56	112M
188	5.04	108	2.51	5000	5 . 0		
168	5.65	121	2.35	5070	5 . 6		
150	6.34	136	2.15	5130	6 . 3		
118	8.05	172	1.79	5250	8 . 0		
104	9.13	196	1.62	5350	9 . 0		
87	10.89	233	1.43	5540	1 1 .		
76	12.54	268	1.21	5680	1 2 .		
65	14.58	313	1.08	5820	1 4 .		
58	16.31	349	0.97	5920	1 6 .		
55	17.39	373	0.9	5970	1 8 .		
265	3.58	77	3.8	7200	M 0 5 2 2 3 . 6 _ M _ _ _ _ 2 . 2 C _ _	56	112M
188	5.04	108	3.53	4820	5 . 0		
168	5.65	121	3.39	4890	5 . 6		
150	6.34	136	3.03	4950	6 . 3		
118	8.05	173	2.6	5060	8 . 0		
104	9.13	196	2.29	5150	9 . 0		
87	10.89	234	1.92	5340	1 1 .		
76	12.54	269	1.58	5480	1 2 .		
65	14.58	313	1.43	5610	1 4 .		
58	16.31	349	1.29	5700	1 6 .		
55	17.39	373	1.21	5750	1 8 .		
46	20.61	442	1.02	5060	2 0 .		
43	22	471	0.95	4450	2 2 .		
152	6.24	134	3.53	7200	M 0 6 2 2 5 . 6 _ M _ _ _ _ 2 . 2 C _ _	61	112M
136	6.99	150	3.39	7200	6 . 3		
121	7.85	168	3.03	7200	8 . 0		
95	9.97	214	2.77	7200	9 . 0		
84	11.3	243	2.5	7200	1 1 .		
70	13.48	290	2.15	7200	1 2 .		
61	15.52	333	1.58	7200	1 4 .		
53	18.05	388	1.54	7200	1 6 .		
47	20.2	433	1.44	7200	1 8 .		
44	21.53	462	1.35	7200	2 0 .		
37	25.51	547	1.14	7200	2 2 .		
35	27.24	584	1.07	7200	2 8 .		
28	33.8	724	0.86	7200	3 2 .		

NOTE

Other output speeds are available using 2 and 8 pole motors - Consult Application Engineering

SERIES M

SELECTION TABLES

GEARED MOTORS

2.2 kW

6 POLE

N2 R/MIN	i	M2 Nm	Fm	N	Unit Designation	Kg	Motor Size
Output Speed	Ratio	Output Torque	Service Factor	Overhung Load	Column Entry [1] Through [20] Spaces to be filled when entering order	Weight	
84	11.35	243	3.18	8620	M 0 7 2 2 1 1 . _ M _ _ _ _ _ 2 . 2 C - -	69	112M
76	12.48	267	2.96	8440	1 2 .		
66	14.34	307	2.63	8126	1 4 .		
58	16.26	348	2.35	7790	1 6 .		
53	17.94	384	2.15	7470	1 8 .		
46	20.54	439	1.9	6963	2 0 .		
41	23.23	496	1.7	6666	2 2 .		
35	26.93	575	1.49	6666	2 8 .		
30	32.12	685	1.26	5217	3 2 .		
27	35.17	749	1.16	5217	3 6 .		
23	42.21	897	0.97	3265	4 5 .		
52	18.26	390	3.48	20000	M 0 8 2 2 1 8 . _ M _ _ _ _ _ 2 . 2 C - -	101	112M
46	20.66	442	3.3	20000	2 0 .		
41	23.32	500	3.08	20000	2 2 .		
34	28.27	604	2.73	20000	2 8 .		
29	32.97	704	2.34	17987	3 2 .		
26	36.21	773	2.13	17718	3 6 .		
21	44.38	947	1.74	16267	4 5 .		
20	48.46	1033	1.6	15492	5 0 .		
17	55.8	1184	1.31	14699	5 6 .		
16	60.33	1273	1.3	14606	M 0 8 3 2 5 6 . _ M _ _ _ _ _ 2 . 2 C - -	102	112M
14	66.02	1394	1.18	12236	6 3 .		
13	74.69	1581	1.04	11076	7 1 .		
11	84.31	1780	0.93	9804	8 0 .		
24	40.25	862	2.87	29500	M 0 9 2 1 4 0 . _ M _ _ _ _ _ 2 . 2 C - -	142	112M
21	44.44	951	2.6	29500	4 5 .		
19	49.07	1049	2.65	29400	5 0 .		
17	55.18	1174	1.66	29390	5 6 .		
16	61.13	1304	1.89	29250	6 3 .		
14	68.74	1464	1.66	28975	7 1 .		
16	59.85	1270	2.08	29200	M 0 9 3 1 5 6 . _ M _ _ _ _ _ 2 . 2 C - -	151	112M
14	66.49	1410	1.87	29100	6 3 .		
13	74.26	1577	1.81	29100	7 1 .		
12	82.51	1751	1.63	29000	8 0 .		
10	93.92	1989	1.33	28800	9 0 .		
9.2	103.68	2198	1.2	28700	1 0 0		
8.2	116.55	2474	1.16	28600	1 1 2		
7.4	128.66	2728	1.05	28500	1 2 5		
6.5	145.2	3067	0.81	28300	1 4 0		
18	51.49	1097	3.53	49500	M 1 0 2 1 5 6 . _ M _ _ _ _ _ 2 . 2 C - -	188	112M
16	57.75	1229	3.38	49400	6 3 .		
15	62.05	1317	3.16	49200	7 1 .		
16	60.23	1275	2.96	49200	M 1 0 3 1 5 6 . _ M _ _ _ _ _ 2 . 2 C - -	205	112M
14	66.93	1418	2.66	49000	6 3 .		
13	71.17	1506	2.93	48900	7 1 .		
12	79.08	1673	2.64	48600	8 0 .		
10	95.44	2019	1.87	47635	9 0 .		
8.6	109.97	2328	1.62	46378	1 0 0		
8.4	112.77	2385	1.85	46425	1 1 2		
7.3	129.94	2746	1.61	46625	1 2 5		
7	135.88	2870	1.45	46450	1 4 0		
6.1	156.57	3299	1.26	46044	1 6 0		
4.3	220.22	4569	0.97	41580	M 1 0 4 1 2 2 5 _ M _ _ _ _ _ 2 . 2 C - -	237	112M
3.9	242.24	5024	0.88	41580	2 5 0		

NOTE

Other output speeds are available using 2 and 8 pole motors - Consult Application Engineering

SERIES M

SELECTION TABLES

GEARED MOTORS

2.2 kW

6 POLE

N2 R/MIN	i	M2 Nm	Fm	N	Unit Designation	Kg	Motor Size
Output Speed	Ratio	Output Torque	Service Factor	Overhung Load	Column Entry <input type="text" value="1"/> Through <input type="text" value="20"/> Spaces to be filled when entering order	Weight	
8.4	113.69	2384	2.66	66600	M 1 3 3 1 1 1 2 _ M _ _ _ _ 2 . 2 C _ _	270	112M
7.5	126.62	2653	2.39	66531	1 2 5		
6.8	139.07	2907	2.22	66420	1 4 0		
6.1	154.89	3234	2	66373	1 6 0		
5.5	173.37	3638	1.75	66232	1 8 0		
5.2	184.46	3878	1.64	66115	2 0 0		
4.5	212.09	4446	1.45	65962	2 2 5		
4.2	226.98	4696	1.35	64632	M 1 3 4 1 2 2 5 _ M _ _ _ _ 2 . 2 C _ _	312	112M
3.8	249.68	5164	1.23	64632	2 5 0		
3.3	286.9	5930	1.07	64632	2 8 0		
2.9	325.33	6714	0.95	64632	3 0 0		
2.6	358.84	7410	0.86	64632	3 6 0		
6.7	142.66	2977	3.39	80900	M 1 4 3 1 1 4 0 _ M _ _ _ _ 2 . 2 C _ _	399	112M
6.1	154.57	3230	3.13	80900	1 6 0		
5.1	185.56	3894	2.82	80900	1 8 0		
4.6	208.15	4359	2.52	80900	2 0 0		
4.5	211.96	4428	2.28	80865	2 2 5		
3.9	246.73	5107	2.07	80613	M 1 4 4 1 2 2 5 _ M _ _ _ _ 2 . 2 C _ _	428	112M
3.5	271.4	5616	1.89	80613	2 5 0		
3	311.86	6449	1.64	80613	2 8 0		
2.7	353.64	7301	1.45	80613	3 0 0		
2.4	390.06	8057	1.32	80613	3 6 0		
2.1	446.71	9219	1.15	80613	4 0 0		
1.9	492.49	10157	1.06	80613	4 5 0		
1.7	556.83	11473	0.94	80613	5 0 0		
1.5	645.58	13285	0.81	80613	6 5 0		

NOTE

Other output speeds are available using 2 and 8 pole motors - Consult Application Engineering

SERIES M

SELECTION TABLES

GEARED MOTORS

3.0 kW

4 POLE

N2 R/MIN	i	M2 Nm	Fm	N	Unit Designation	Kg	Motor Size
Output Speed	Ratio	Output Torque	Service Factor	Overhung Load	Column Entry [1] Through [20] Spaces to be filled when entering order	Weight	
398	3.59	68	1.46	3100	M 0 2 2 2 3 . 6 _ M _ _ _ _ 3 . 0 A _ _	39	100L
284	5.03	96	1.21	3100	5 . 0		
258	5.55	106	1.15	3100	5 . 6		
227	6.30	120	1.06	3100	6 . 3		
179	8.00	152	0.89	2600	8 . 0		
157	9.09	173	0.81	2300	9 . 0		
398	3.59	68	1.73	2300	M 0 3 2 2 3 . 6 _ M _ _ _ _ 3 . 0 A _ _	39	100L
284	5.03	96	1.41	2300	5 . 0		
258	5.55	106	1.33	2300	5 . 6		
227	6.30	120	1.23	2300	6 . 3		
179	8.00	152	1.06	2300	8 . 0		
157	9.09	173	0.97	2200	9 . 0		
128	11.15	212	0.84	2000	1 1 .		
398	3.58	69	2.91	4476	M 0 4 2 2 3 . 6 _ M _ _ _ _ 3 . 0 A _ _	49	100L
283	5.04	98	2.41	4648	5 . 0		
252	5.65	110	2.26	4720	5 . 6		
225	6.34	123	2.12	4791	6 . 3		
177	8.05	157	1.84	4911	8 . 0		
156	9.13	177	1.68	4968	9 . 0		
131	10.89	212	1.46	5026	1 1 .		
114	12.54	244	1.16	5202	1 2 .		
98	14.58	284	1.04	5343	1 4 .		
87	16.31	317	0.96	5110	1 6 .		
82	17.39	339	0.92	5140	1 8 .		
283	5.04	98	3.87	4395	M 0 5 2 2 5 . 0 _ M _ _ _ _ 3 . 0 A _ _	49	100L
252	5.65	110	3.73	4450	5 . 6		
225	6.34	123	3.34	4504	6 . 3		
177	8.05	157	2.86	4733	8 . 0		
156	9.13	178	2.52	4790	9 . 0		
131	10.89	212	2.11	4850	1 1 .		
114	12.54	244	1.74	4855	1 2 .		
98	14.58	284	1.58	4762	1 4 .		
87	16.31	317	1.42	5204	1 6 .		
82	17.39	339	1.33	5254	1 8 .		
69	20.61	401	1.12	5221	2 0 .		
65	22	429	1.05	4500	2 2 .		
52	27.3	532	0.85	3280	2 8 .		
228	6.24	122	3.87	7200	M 0 6 2 2 5 . 6 _ M _ _ _ _ 3 . 0 A _ _	54	100L
204	6.99	136	3.73	7200	6 . 3		
182	7.85	153	3.34	7200	8 . 0		
143	9.97	194	3.05	7200	9 . 0		
126	11.3	221	2.73	7200	1 1 .		
106	13.48	263	2.33	7200	1 2 .		
92	15.52	303	1.74	7200	1 4 .		
79	18.05	352	1.69	7200	1 6 .		
71	20.2	394	1.59	7200	1 8 .		
66	21.53	419	1.49	7200	2 0 .		
56	25.51	497	1.26	7200	2 2 .		
52	27.24	530	1.18	7200	2 8 .		
42	33.8	658	0.95	7200	3 2 .		
36	39.86	773	0.81	7200	3 6 .		

NOTE

Other output speeds are available using 2 and 8 pole motors - Consult Application Engineering

SERIES M

SELECTION TABLES

GEARED MOTORS

3.0 kW

4 POLE

N2 R/MIN	i	M2 Nm	Fm	N	Unit Designation	Kg	Motor Size
Output Speed	Ratio	Output Torque	Service Factor	Overhung Load	Column Entry [1] Through [20] Spaces to be filled when entering order	Weight	
126	11.35	221	3.23	7698	M 0 7 2 2 1 1 . _ M _ _ _ _ 3 . 0 A - -	62	100L
114	12.48	243	3.03	7607	1 2 .		
99	14.34	279	2.71	7670	1 4 .		
88	16.26	316	2.48	7956	1 6 .		
79	17.94	349	2.27	8480	1 8 .		
69	20.54	399	2.01	8190	2 0 .		
61	23.23	451	1.8	7040	2 2 .		
53	26.93	523	1.58	6400	2 8 .		
44	32.12	623	1.35	6898	3 2 .		
41	35.17	682	1.24	6012	3 6 .		
34	42.21	815	1.06	5750	4 5 .		
78	18.26	354	3.83	18200	M 0 8 2 2 1 8 . _ M _ _ _ _ 3 . 0 A - -	94	100L
69	20.66	401	3.64	18800	2 0 .		
61	23.32	456	3.37	19500	2 2 .		
50	28.27	548	2.9	20000	2 8 .		
43	32.97	640	2.55	18667	3 2 .		
39	36.21	702	2.35	18492	3 6 .		
32	44.38	860	1.92	17475	4 5 .		
29	48.46	939	1.76	17036	5 0 .		
26	55.8	1078	1.43	18755	5 6 .		
24	60.33	1154	1.39	18100	M 0 8 3 2 5 6 . _ M _ _ _ _ 3 . 0 A - -	95	100L
22	66.02	1268	1.3	16724	6 3 .		
19	74.69	1430	1.15	14693	7 1 .		
17	84.31	1614	1.02	16100	8 0 .		
14	102.2	1959	0.84	11200	1 0 0		
40	35.67	693	3.37	29600	M 0 9 2 1 3 6 . _ M _ _ _ _ 3 . 0 A - -	135	100L
35	40.25	783	3.15	29600	4 0 .		
32	44.44	865	2.85	29492	4 5 .		
29	49.07	953	2.54	29478	5 0 .		
26	55.18	1068	1.88	29407	5 6 .		
23	61.13	1187	2.08	29370	6 3 .		
21	68.74	1332	1.85	29234	7 1 .		
24	59.85	1155	2.24	29335	M 0 9 3 1 5 6 . _ M _ _ _ _ 3 . 0 A - -	144	100L
21	66.49	1281	2.06	29235	6 3 .		
19	74.26	1431	2	29194	7 1 .		
17	82.51	1590	1.8	29120	8 0 .		
15	93.92	1806	1.46	28944	9 0 .		
14	103.68	1994	1.32	28813	1 0 0		
12	116.55	2244	1.27	28779	1 1 2		
11	128.66	2480	1.15	28648	1 2 5		
10	145.2	2782	0.89	28400	1 4 0		
8.9	160.29	3065	0.81	28300	1 6 0		
28	51.49	1001	3.87	46600	M 1 0 2 1 5 6 . _ M _ _ _ _ 3 . 0 A - -	181	100L
25	57.75	1113	3.73	48400	6 3 .		
23	62.05	1198	3.47	49452	7 1 .		
24	60.23	1157	3.26	29500	M 1 0 3 1 5 6 . _ M _ _ _ _ 3 . 0 A - -	193	100L
21	66.93	1285	2.93	29500	6 3 .		
20	71.17	1366	3.23	29500	7 1 .		
18	79.08	1517	2.91	48921	8 0 .		
15	95.44	1835	2.05	48286	9 0 .		
13	109.97	2111	1.79	47825	1 0 0		
13	112.77	2164	2.04	47825	1 1 2		
11	129.94	2492	1.77	47287	1 2 5		
10	135.88	2596	1.6	47214	1 4 0		
9.1	156.57	2995	1.39	46586	1 6 0		
6.5	220.22	4145	1.06	41580	M 1 0 4 1 2 2 5 _ M _ _ _ _ 3 . 0 A - -	230	100L
5.9	242.24	4559	0.97	41580	2 5 0		
5.1	278.36	5237	0.84	41580	2 8 0		

NOTE

Other output speeds are available using 2 and 8 pole motors - Consult Application Engineering

SERIES M

SELECTION TABLES

GEARED MOTORS

3.0 kW

4 POLE

N2 R/MIN	i	M2 Nm	Fm	N	Unit Designation	Kg	Motor Size
Output Speed	Ratio	Output Torque	Service Factor	Overhung Load	Column Entry <input type="text" value="1"/> Through <input type="text" value="20"/> Spaces to be filled when entering order	Weight	
16	90.75	1736	3.57	66900	M 1 3 3 1 9 0 . _ M _ _ _ _ 3 . 0 A _ _	263	100L
14	101.07	1933	3.21	66700	1 0 0		
13	113.69	2165	2.93	66738	1 1 2		
11	126.62	2410	2.63	66611	1 2 5		
10	139.07	2639	2.45	66511	1 4 0		
9.2	154.89	2938	2.2	66484	1 6 0		
8.2	173.37	3307	1.92	66345	1 8 0		
7.7	184.46	3524	1.8	66245	2 0 0		
6.7	212.09	4032	1.6	66103	2 2 5		
6.3	226.98	4263	1.49	64632	M 1 3 4 1 2 2 5 _ M _ _ _ _ 3 . 0 A _ _	305	100L
5.7	249.68	4689	1.35	64632	2 5 0		
5	286.9	5386	1.18	64632	2 8 0		
4.4	325.33	6098	1.04	64632	3 0 0		
4	358.84	6731	0.94	64632	3 6 0		
3.5	410.95	7704	0.82	64632	4 0 0		
10	142.66	2704	3.73	80900	M 1 4 3 1 1 4 0 _ M _ _ _ _ 3 . 0 A _ _	392	100L
9.2	154.57	2936	3.44	80900	1 6 0		
7.7	185.56	3538	3.11	80900	1 8 0		
6.8	208.15	3959	2.78	80900	2 0 0		
6.7	211.96	4025	2.51	80900	2 2 5		
5.8	246.73	4639	2.28	80613	M 1 4 4 1 2 2 5 _ M _ _ _ _ 3 . 0 A _ _	421	100L
5.3	271.4	5102	2.08	80613	2 5 0		
4.6	311.86	5859	1.81	80613	2 8 0		
4	353.64	6634	1.6	80613	3 0 0		
3.7	390.06	7322	1.45	80613	3 6 0		
3.2	446.71	8379	1.26	80613	4 0 0		
2.9	492.49	9231	1.17	80613	4 5 0		
2.6	556.83	10428	1.03	80613	5 0 0		
2.2	645.58	12077	0.89	80613	6 5 0		

NOTE

Other output speeds are available using 2 and 8 pole motors - Consult Application Engineering

SERIES M

SELECTION TABLES

GEARED MOTORS

3.0 kW

6 POLE

N2 R/MIN	i	M2 Nm	Fm	N	Unit Designation	Kg	Motor Size
Output Speed	Ratio	Output Torque	Service Factor	Overhung Load	Column Entry [1] Through [20] Spaces to be filled when entering order	Weight	
260	3.68	107	2.87	8020	M 0 7 2 2 3 . 6 _ M _ _ _ _ 3 . 0 C _ _	88	132S
187	5.09	148	2.87	8470	5 . 0		
167	5.72	166	2.87	8620	5 . 6		
152	6.29	183	2.87	8750	6 . 3		
116	8.22	239	2.87	9090	8 . 0		
102	9.34	271	2.73	9240	9 . 0		
84	11.35	330	2.34	7950	1 1 .		
77	12.48	363	2.18	7683	1 2 .		
67	14.34	417	1.94	7218	1 4 .		
59	16.26	472	1.73	6718	1 6 .		
53	17.94	522	1.58	6243	1 8 .		
46	20.54	596	1.4	5491	2 0 .		
41	23.23	673	1.26	5050	2 2 .		
35	26.93	781	1.1	5050	2 8 .		
30	32.12	930	0.93	2898	3 2 .		
27	35.17	1017	0.85	2898	3 6 .		
63	15.04	436	3.55	19300	M 0 8 2 2 1 4 . _ M _ _ _ _ 3 . 0 C _ _	121	132S
57	16.69	483	2.93	19900	1 6 .		
52	18.26	529	2.57	18460	1 8 .		
46	20.66	599	2.43	18233	2 0 .		
41	23.32	678	2.27	18181	2 2 .		
34	28.27	819	2.01	18181	2 8 .		
29	32.97	955	1.73	15687	3 2 .		
26	36.21	1049	1.57	15111	3 6 .		
22	44.38	1285	1.28	13552	4 5 .		
20	48.46	1401	1.18	12214	5 0 .		
17	55.8	1606	0.96	11775	5 6 .		
16	60.33	1727	0.96	10683	M 0 8 3 2 5 6 . _ M _ _ _ _ 3 . 0 C _ _	126	132S
14	66.02	1891	0.87	7953	6 3 .		
37	26.04	758	3.48	29500	M 0 9 2 1 2 5 . _ M _ _ _ _ 3 . 0 C _ _	162	132S
33	28.74	837	3.15	29500	2 8 .		
30	32.31	940	2.83	29500	3 2 .		
27	35.67	1038	2.59	29400	3 6 .		
24	40.25	1169	2.11	28790	4 0 .		
21	44.44	1290	1.91	29303	4 5 .		
19	49.07	1423	1.95	29067	5 0 .		
17	55.18	1593	1.22	29150	5 6 .		
16	61.13	1769	1.4	28995	6 3 .		
14	68.74	1985	1.22	28520	7 1 .		
22	42.7	1242	3.35	49400	M 1 0 2 1 4 5 . _ M _ _ _ _ 3 . 0 C _ _	208	132S
20	47.93	1386	3.04	49100	5 0 .		
19	51.49	1488	2.6	48845	5 6 .		
17	57.75	1668	2.49	48681	6 3 .		
15	62.05	1787	2.33	48436	7 1 .		
15	64.17	1851	3.35	66800	M 1 3 3 1 6 3 . _ M _ _ _ _ 3 . 0 C _ _	290	132S
13	71.32	2039	3.11	66700	7 1 .		
12	80.39	2298	2.76	66600	8 0 .		
11	90.75	2593	2.39	66600	9 0 .		
9.4	101.07	2885	2.15	66500	1 0 0		
8.4	113.69	3234	1.96	66328	1 1 2		
7.5	126.62	3599	1.76	66225	1 2 5		
6.9	139.07	3943	1.64	66100	1 4 0		
6.2	154.89	4387	1.47	66000	1 6 0		
5.5	173.37	4935	1.29	65812	1 8 0		
5.2	184.46	5260	1.21	65675	2 0 0		
4.5	212.09	6031	1.07	65462	2 2 5		
7.6	124.89	3551	3.1	80900	M 1 4 3 1 1 1 2 _ M _ _ _ _ 3 . 0 C _ _	419	132S
7.1	135.31	3852	2.86	80900	1 2 5		
6.7	142.66	4039	2.5	80900	1 4 0		
6.2	154.57	4382	2.3	80900	1 6 0		
5.1	185.56	5282	2.08	80900	1 8 0		
4.6	208.15	5913	1.86	80854	2 0 0		
4.5	211.96	6007	1.68	80825	2 2 5		

NOTE

Other output speeds are available using 2 and 8 pole motors - Consult Application Engineering

SERIES M

SELECTION TABLES

GEARED MOTORS

4.0 kW

4 POLE

N2 R/MIN	i	M2 Nm	Fm	N	Unit Designation	Kg	Motor Size
Output Speed	Ratio	Output Torque	Service Factor	Overhung Load	Column Entry <input type="text" value="1"/> Through <input type="text" value="20"/> Spaces to be filled when entering order	Weight	
398	3.59	91	1.10	3100	M 0 2 2 2 3 . 6 _ M _ _ _ _ 4 . 0 A _ _	46	112M
284	5.03	128	0.91	2650	5 . 0		
258	5.55	141	0.86	2400	5 . 6		
398	3.59	91	1.30	2300	M 0 3 2 2 3 . 6 _ M _ _ _ _ 4 . 0 A _ _	46	112M
284	5.03	128	1.06	2300	5 . 0		
258	5.55	141	0.99	2300	5 . 6		
227	6.30	160	0.92	2100	6 . 3		
400	3.58	92	2.19	4413	M 0 4 2 2 3 . 6 _ M _ _ _ _ 4 . 0 A _ _	56	112M
285	5.04	129	1.82	4561	5 . 0		
254	5.65	145	1.71	4620	5 . 6		
226	6.34	163	1.6	4678	6 . 3		
178	8.05	208	1.39	4770	8 . 0		
157	9.13	235	1.27	4809	9 . 0		
132	10.89	281	1.1	4835	1 1 .		
114	12.54	323	0.88	4930	1 2 .		
400	3.58	92	3.17	4160	M 0 5 2 2 3 . 6 _ M _ _ _ _ 4 . 0 A _ _	56	112M
285	5.04	130	2.92	4345	5 . 0		
254	5.65	146	2.82	4394	5 . 6		
226	6.34	163	2.52	4438	6 . 3		
178	8.05	208	2.16	4596	8 . 0		
157	9.13	236	1.9	4634	9 . 0		
132	10.89	281	1.6	4666	1 1 .		
114	12.54	324	1.31	4653	1 2 .		
98	14.58	377	1.19	4445	1 4 .		
88	16.31	421	1.07	4920	1 6 .		
83	17.39	449	1	4950	1 8 .		
70	20.61	531	0.85	4790	2 0 .		
323	4.44	114	3.17	7200	M 0 6 2 2 5 . 0 _ M _ _ _ _ 4 . 0 A _ _	61	112M
230	6.24	162	2.92	7200	5 . 6		
205	6.99	180	2.82	7200	6 . 3		
183	7.85	202	2.52	7200	8 . 0		
144	9.97	258	2.3	7200	9 . 0		
127	11.3	292	2.06	7200	1 1 .		
106	13.48	348	1.76	7200	1 2 .		
92	15.52	401	1.31	7200	1 4 .		
79	18.05	466	1.28	7200	1 6 .		
71	20.2	521	1.2	7200	1 8 .		
67	21.53	556	1.13	7200	2 0 .		
56	25.51	658	0.95	7200	2 2 .		
53	27.24	702	0.89	7200	2 8 .		

NOTE

Other output speeds are available using 2 and 8 pole motors - Consult Application Engineering

SERIES M

SELECTION TABLES

GEARED MOTORS

4.0 kW

4 POLE

N2 R/MIN	i	M2 Nm	Fm	N	Unit Designation	Kg	Motor Size
Output Speed	Ratio	Output Torque	Service Factor	Overhung Load	Column Entry [1] Through [20] Spaces to be filled when entering order	Weight	
390	3.68	94	3.24	7490	M 0 7 2 2 3 . 6 _ M _ _ _ _ 4 . 0 A _ _	69	112M
282	5.09	131	3.24	7780	5 . 0		
251	5.72	147	3.24	7930	5 . 6		
228	6.29	161	3.24	8050	6 . 3		
175	8.22	213	2.97	8370	8 . 0		
154	9.34	241	2.75	8510	9 . 0		
126	11.35	293	2.44	7128	1 1 .		
115	12.48	321	2.29	6943	1 2 .		
100	14.34	370	2.04	6844	1 4 .		
88	16.26	419	1.88	7110	1 6 .		
80	17.94	463	1.71	7804	1 8 .		
70	20.54	529	1.52	7385	2 0 .		
62	23.23	597	1.36	5724	2 2 .		
53	26.93	693	1.19	4800	2 8 .		
45	32.12	826	1.02	5520	3 2 .		
41	35.17	903	0.94	4240	3 6 .		
86	16.69	428	3.32	17400	M 0 8 2 2 1 6 . _ M _ _ _ _ 4 . 0 A _ _	101	112M
79	18.26	469	2.89	16986	1 8 .		
69	20.66	531	2.75	17340	2 0 .		
62	23.32	604	2.55	17752	2 2 .		
51	28.27	726	2.19	17785	2 8 .		
44	32.97	847	1.92	16763	3 2 .		
40	36.21	930	1.77	16338	3 6 .		
32	44.38	1139	1.45	15792	4 5 .		
30	48.46	1244	1.33	15060	5 0 .		
26	55.8	1427	1.08	18100	5 6 .		
24	60.33	1528	1.05	17100	M 0 8 3 2 5 6 . _ M _ _ _ _ 4 . 0 A _ _	102	112M
22	66.02	1679	0.98	15000	6 3 .		
19	74.69	1894	0.87	11900	7 1 .		
55	26.04	671	3.93	27400	M 0 9 2 1 2 5 . _ M _ _ _ _ 4 . 0 A _ _	142	112M
50	28.74	740	3.56	28200	2 8 .		
44	32.31	837	2.77	29300	3 2 .		
40	35.67	918	2.55	28783	3 6 .		
36	40.25	1037	2.38	29111	4 0 .		
32	44.44	1146	2.15	29338	4 5 .		
29	49.07	1262	1.92	29305	5 0 .		
26	55.18	1415	1.42	29212	5 6 .		
23	61.13	1572	1.57	29151	6 3 .		
21	68.74	1763	1.4	28990	7 1 .		
24	59.85	1530	1.69	29100	M 0 9 3 1 5 6 . _ M _ _ _ _ 4 . 0 A _ _	151	112M
22	66.49	1696	1.56	29000	6 3 .		
19	74.26	1895	1.51	28900	7 1 .		
17	82.51	2105	1.36	28800	8 0 .		
15	93.92	2392	1.1	28600	9 0 .		
14	103.68	2641	1	28400	1 0 0		
12	116.55	2971	0.96	28400	1 1 2		
11	128.66	3283	0.87	28200	1 2 5		

NOTE

Other output speeds are available using 2 and 8 pole motors - Consult Application Engineering

SERIES M

SELECTION TABLES

GEARED MOTORS

4.0 kW

4 POLE

N2 R/MIN	i	M2 Nm	Fm	N	Unit Designation	Kg	Motor Size
Output Speed	Ratio	Output Torque	Service Factor	Overhung Load	Column Entry [1] Through [20] Spaces to be filled when entering order	Weight	
34	42.7	1098	3.79	43600	M 1 0 2 1 4 5 . _ M _ _ _ _ 4 . 0 A - -	188	112M
30	47.93	1227	3.41	45100	5 0 .		
28	51.49	1325	2.92	46066	5 6 .		
25	57.75	1474	2.82	47800	6 3 .		
23	62.05	1586	2.62	48813	7 1 .		
24	60.23	1532	2.46	29411	M 1 0 3 1 5 6 . _ M _ _ _ _ 4 . 0 A - -	205	112M
21	66.93	1702	2.21	29411	6 3 .		
20	71.17	1809	2.44	29411	7 1 .		
18	79.08	2009	2.19	48094	8 0 .		
15	95.44	2430	1.55	47267	9 0 .		
13	109.97	2795	1.35	46641	1 0 0		
13	112.77	2865	1.54	46641	1 1 2		
11	129.94	3300	1.34	45946	1 2 5		
11	135.88	3438	1.21	45824	1 4 0		
9.2	156.57	3965	1.05	45000	1 6 0		
6.5	220.22	5489	0.8	41580	M 1 0 4 1 2 2 5 _ M _ _ _ _ 4 . 0 A - -	237	112M
22	64.17	1637	3.79	66900	M 1 3 3 1 6 3 . _ M _ _ _ _ 4 . 0 A - -	270	112M
20	71.32	1807	3.51	66800	7 1 .		
18	80.39	2036	3.12	66841	8 0 .		
16	90.75	2299	2.7	66800	9 0 .		
14	101.07	2559	2.42	66611	1 0 0		
13	113.69	2867	2.21	66507	1 1 2		
11	126.62	3192	1.99	66342	1 2 5		
10	139.07	3495	1.85	66242	1 4 0		
9.3	154.89	3891	1.66	66176	1 6 0		
8.3	173.37	4379	1.45	65981	1 8 0		
7.8	184.46	4666	1.36	65881	2 0 0		
6.8	212.09	5339	1.21	65678	2 2 5		
6.3	226.98	5645	1.12	64632	M 1 3 4 1 2 2 5 _ M _ _ _ _ 4 . 0 A - -	312	112M
5.7	249.68	6208	1.02	64632	2 5 0		
5	286.9	7131	0.89	64632	2 8 0		
11	124.89	3153	3.49	80900	M 1 4 3 1 1 1 2 _ M _ _ _ _ 4 . 0 A - -	399	112M
11	135.31	3419	3.22	80900	1 2 5		
10	142.66	3580	2.82	80900	1 4 0		
9.3	154.57	3887	2.6	80900	1 6 0		
7.7	185.56	4684	2.35	80900	1 8 0		
6.9	208.15	5242	2.1	80900	2 0 0		
6.8	211.96	5329	1.9	80900	2 2 5		
5.8	246.73	6143	1.72	80613	M 1 4 4 1 2 2 5 _ M _ _ _ _ 4 . 0 A - -	428	112M
5.3	271.4	6755	1.57	80613	2 5 0		
4.6	311.86	7758	1.37	80613	2 8 0		
4.1	353.64	8784	1.21	80613	3 0 0		
3.7	390.06	9694	1.09	80613	3 6 0		
3.2	446.71	11095	0.95	80613	4 0 0		
2.9	492.49	12222	0.88	80613	4 5 0		

NOTE

Other output speeds are available using 2 and 8 pole motors - Consult Application Engineering

SERIES M

SELECTION TABLES

GEARED MOTORS

4.0 kW

6 POLE

N2 R/MIN	i	M2 Nm	Fm	N	Unit Designation	Kg	Motor Size
Output Speed	Ratio	Output Torque	Service Factor	Overhung Load	Column Entry [1] Through [20] Spaces to be filled when entering order	Weight	
261	3.68	141	2.16	7888	M 0 7 2 2 3 . 6 - M _ _ _ _ 4 . 0 C - -	92	132M
188	5.09	196	2.16	8290	5 . 0		
168	5.72	221	2.16	8420	5 . 6		
153	6.29	243	2.16	8522	6 . 3		
117	8.22	317	2.16	8334	8 . 0		
103	9.34	360	2.06	8232	9 . 0		
85	11.35	437	1.76	7114	1 1 .		
77	12.48	482	1.64	6738	1 2 .		
67	14.34	553	1.46	6083	1 4 .		
59	16.26	626	1.3	5379	1 6 .		
54	17.94	692	1.19	4710	1 8 .		
47	20.54	791	1.06	3650	2 0 .		
41	23.23	893	0.95	3030	2 2 .		
36	26.93	1036	0.83	3030	2 8 .		
115	8.33	322	3.97	16700	M 0 8 2 2 8 . 0 - M _ _ _ _ 4 . 0 C - -	125	132M
103	9.35	359	3.7	17000	9 . 0		
84	11.47	443	3.22	17500	1 1 .		
74	12.92	498	2.95	18100	1 2 .		
64	15.04	579	2.67	17670	1 4 .		
58	16.69	641	2.21	17998	1 6 .		
53	18.26	702	1.93	16537	1 8 .		
46	20.66	795	1.84	16025	2 0 .		
41	23.32	900	1.71	15909	2 2 .		
34	28.27	1087	1.52	15909	2 8 .		
29	32.97	1266	1.3	12812	3 2 .		
27	36.21	1392	1.18	11852	3 6 .		
22	44.38	1705	0.97	10159	4 5 .		
20	48.46	1859	0.89	8116	5 0 .		
52	18.43	713	3.7	27900	M 0 9 2 1 1 8 . - M _ _ _ _ 4 . 0 C - -	166	132M
47	20.59	800	3.58	29000	2 0 .		
42	22.87	886	3.22	29500	2 2 .		
37	26.04	1005	2.62	28425	2 5 .		
33	28.74	1110	2.38	28275	2 8 .		
30	32.31	1247	2.13	28250	3 2 .		
27	35.67	1377	1.95	27958	3 6 .		
24	40.25	1551	1.59	27904	4 0 .		
22	44.44	1712	1.44	29058	4 5 .		
20	49.07	1887	1.47	28652	5 0 .		
17	55.18	2113	0.92	28850	5 6 .		
16	61.13	2346	1.05	28677	6 3 .		
14	68.74	2634	0.92	27952	7 1 .		
32	29.99	1160	3.25	44300	M 1 0 2 1 2 8 . - M _ _ _ _ 4 . 0 C - -	212	132M
31	30.76	1183	3.72	44700	3 2 .		
27	35.44	1367	3.22	46600	3 6 .		
26	37.06	1422	2.92	47300	4 0 .		
22	42.7	1647	2.53	48566	4 5 .		
20	47.93	1838	2.3	47958	5 0 .		
19	51.49	1974	1.96	48027	5 6 .		
17	57.75	2212	1.88	47784	6 3 .		
15	62.05	2370	1.75	47481	7 1 .		
16	60.23	2295	1.64	49200	M 1 0 3 1 5 6 . - M _ _ _ _ 4 . 0 C - -	239	132M
14	66.93	2551	1.48	49000	6 3 .		
13	71.17	2709	1.63	48900	7 1 .		
12	79.08	3010	1.47	46358	8 0 .		
10	95.44	3633	1.04	44125	9 0 .		
8.7	109.97	4188	0.9	40408	1 0 0		
8.5	112.77	4291	1.03	40575	1 1 2		
7.4	129.94	4941	0.89	42575	1 2 5		
7.1	135.88	5164	0.81	42113	1 4 0		
17	56.93	2175	2.85	66700	M 1 3 3 1 5 6 . - M _ _ _ _ 4 . 0 C - -	294	132M
15	64.17	2455	2.53	66741	6 3 .		
13	71.32	2705	2.35	66616	7 1 .		
12	80.39	3049	2.08	66516	8 0 .		
11	90.75	3439	1.8	66437	9 0 .		
9.5	101.07	3827	1.62	66325	1 0 0		
8.4	113.69	4290	1.48	65988	1 1 2		
7.6	126.62	4774	1.33	65841	1 2 5		
6.9	139.07	5230	1.24	65700	1 4 0		
6.2	154.89	5819	1.11	65533	1 6 0		
5.5	173.37	6546	0.97	65287	1 8 0		
5.2	184.46	6978	0.91	65125	2 0 0		
4.5	212.09	8000	0.81	64837	2 2 5		
10	94.35	3580	3.1	80900	M 1 4 3 1 9 0 . - M _ _ _ _ 4 . 0 C - -	423	132M
9.4	102.23	3860	2.88	80900	1 0 0		
7.7	124.89	4710	2.34	80900	1 1 2		
7.1	135.31	5110	2.15	80900	1 2 5		
6.7	142.66	5358	1.88	80900	1 4 0		
6.2	154.57	5812	1.74	80900	1 6 0		
5.2	185.56	7006	1.57	80900	1 8 0		
4.6	208.15	7843	1.4	80798	2 0 0		
4.5	211.96	7968	1.27	80775	2 2 5		

NOTE

Other output speeds are available using 2 and 8 pole motors - Consult Application Engineering

SERIES M

SELECTION TABLES

GEARED MOTORS

5.5 kW

4 POLE

N2 R/MIN	i	M2 Nm	Fm	N	Unit Designation	Kg	Motor Size
Output Speed	Ratio	Output Torque	Service Factor	Overhung Load	Column Entry <input type="text" value="1"/> Through <input type="text" value="20"/> Spaces to be filled when entering order	Weight	
399	3.58	127	1.59	4320	M 0 4 2 2 3 . 6 _ M _ _ _ _ 5 . 5 A _ _	70	132S
284	5.04	179	1.32	4430	5 . 0		
253	5.65	200	1.24	4470	5 . 6		
226	6.34	226	1.16	4510	6 . 3		
178	8.05	287	1.01	4560	8 . 0		
157	9.13	325	0.92	4570	9 . 0		
399	3.58	127	2.3	4160	M 0 5 2 2 3 . 6 _ M _ _ _ _ 5 . 5 A _ _	70	132S
284	5.04	180	2.12	4270	5 . 0		
253	5.65	201	2.04	4310	5 . 6		
226	6.34	225	1.83	4340	6 . 3		
178	8.05	287	1.56	4390	8 . 0		
157	9.13	326	1.38	4400	9 . 0		
131	10.89	389	1.16	4390	1 1 .		
114	12.54	447	0.95	4350	1 2 .		
98	14.58	520	0.86	3970	1 4 .		
322	4.44	157	2.3	7200	M 0 6 2 2 5 . 0 _ M _ _ _ _ 5 . 5 A _ _	75	132S
229	6.24	223	2.12	7200	5 . 6		
204	6.99	249	2.04	7200	6 . 3		
182	7.85	279	1.83	7200	8 . 0		
143	9.97	356	1.67	7200	9 . 0		
127	11.3	403	1.5	7200	1 1 .		
106	13.48	480	1.27	7200	1 2 .		
92	15.52	554	0.95	7200	1 4 .		
79	18.05	644	0.93	7200	1 6 .		
71	20.2	719	0.87	7200	1 8 .		
66	21.53	767	0.82	7200	2 0 .		
392	3.68	129	2.37	7393	M 0 7 2 2 3 . 6 _ M _ _ _ _ 5 . 5 A _ _	88	132S
283	5.09	179	2.37	7647	5 . 0		
252	5.72	201	2.37	7709	5 . 6		
229	6.29	221	2.37	7732	6 . 3		
175	8.22	292	2.17	7722	8 . 0		
154	9.34	330	2	7667	9 . 0		
127	11.35	401	1.78	6273	1 1 .		
115	12.48	441	1.67	5948	1 2 .		
100	14.34	507	1.49	5604	1 4 .		
89	16.26	574	1.37	5840	1 6 .		
80	17.94	634	1.25	6791	1 8 .		
70	20.54	725	1.11	6178	2 0 .		
62	23.23	818	0.99	3751	2 2 .		
53	26.93	949	0.87	2400	2 8 .		

NOTE

Other output speeds are available using 2 and 8 pole motors - Consult Application Engineering

SERIES M

SELECTION TABLES

GEARED MOTORS

5.5 kW

4 POLE

N2 R/MIN	i	M2 Nm	Fm	N	Unit Designation	Kg	Motor Size
Output Speed	Ratio	Output Torque	Service Factor	Overhung Load	Column Entry <input type="text" value="1"/> Through <input type="text" value="20"/> Spaces to be filled when entering order	Weight	
173	8.33	295	3.95	15336	M 0 8 2 2 8 . 0 _ M _ _ _ _ 5 . 5 A _ _	121	132S
154	9.35	331	3.68	15648	9 . 0		
126	11.47	405	3.23	16175	1 1 .		
111	12.92	455	2.94	16393	1 2 .		
96	15.04	534	2.65	16821	1 4 .		
86	16.69	586	2.42	15526	1 6 .		
79	18.26	643	2.11	15166	1 8 .		
70	20.66	728	2	15150	2 0 .		
62	23.32	828	1.86	15130	2 2 .		
51	28.27	994	1.6	14463	2 8 .		
44	32.97	1161	1.4	13907	3 2 .		
40	36.21	1274	1.29	13107	3 6 .		
32	44.38	1562	1.06	13268	4 5 .		
30	48.46	1704	0.97	12097	5 0 .		
70	20.59	728	3.88	25256	M 0 9 2 1 2 0 . _ M _ _ _ _ 5 . 5 A _ _	162	132S
63	22.87	812	3.52	26068	2 2 .		
55	26.04	919	2.87	26609	2 5 .		
50	28.74	1015	2.6	27177	2 8 .		
45	32.31	1147	2.02	28168	3 2 .		
40	35.67	1258	1.86	27558	3 6 .		
36	40.25	1421	1.74	28377	4 0 .		
32	44.44	1570	1.57	29107	4 5 .		
29	49.07	1729	1.4	29046	5 0 .		
26	55.18	1939	1.04	28919	5 6 .		
24	61.13	2154	1.15	28821	6 3 .		
21	68.74	2416	1.02	28624	7 1 .		
48	29.99	1059	3.56	38534	M 1 0 2 1 2 8 . _ M _ _ _ _ 5 . 5 A _ _	208	132S
41	35.44	1252	3.52	40553	3 6 .		
39	37.06	1309	3.18	41131	4 0 .		
34	42.7	1505	2.76	42931	4 5 .		
30	47.93	1681	2.49	44336	5 0 .		
28	51.49	1816	2.13	45266	5 6 .		
25	57.75	2020	2.06	46900	6 3 .		
23	62.05	2173	1.91	47854	7 1 .		
24	60.23	2100	1.79	29277	M 1 0 3 1 5 6 . _ M _ _ _ _ 5 . 5 A _ _	235	132S
22	66.93	2332	1.62	29277	6 3 .		
20	71.17	2479	1.78	29277	7 1 .		
18	79.08	2753	1.6	46853	8 0 .		
15	95.44	3329	1.13	45738	9 0 .		
13	109.97	3831	0.98	44866	1 0 0		
13	112.77	3926	1.12	44866	1 1 2		
11	129.94	4522	0.98	43934	1 2 5		
11	135.88	4711	0.88	43739	1 4 0		
25	56.93	1981	3.12	66701	M 1 3 3 1 5 6 . _ M _ _ _ _ 5 . 5 A _ _	290	132S
22	64.17	2244	2.76	66848	6 3 .		
20	71.32	2476	2.56	66731	7 1 .		
18	80.39	2791	2.28	66754	8 0 .		
16	90.75	3150	1.97	66650	9 0 .		
14	101.07	3507	1.77	66477	1 0 0		
13	113.69	3929	1.62	66161	1 1 2		
11	126.62	4374	1.45	65938	1 2 5		
10	139.07	4789	1.35	65838	1 4 0		
9.3	154.89	5331	1.21	65715	1 6 0		
8.3	173.37	6001	1.06	65436	1 8 0		
7.8	184.46	6394	0.99	65336	2 0 0		
6.8	212.09	7316	0.88	65042	2 2 5		
17	86.76	3000	3.67	80900	M 1 4 3 1 8 0 . _ M _ _ _ _ 5 . 5 A _ _	419	132S
15	94.35	3269	3.39	80900	9 0 .		
14	102.23	3553	3.12	80900	1 0 0		
12	124.89	4320	2.55	80900	1 1 2		
11	135.31	4686	2.35	80900	1 2 5		
10	142.66	4906	2.06	80900	1 4 0		
9.3	154.57	5327	1.9	80900	1 6 0		
7.8	185.56	6419	1.71	80900	1 8 0		
6.9	208.15	7183	1.53	80900	2 0 0		
6.8	211.96	7302	1.38	80900	2 2 5		
5.8	246.73	8476	1.25	80613	M 1 4 4 1 2 2 5 _ M _ _ _ _ 5 . 5 A _ _	442	132S
5.3	271.4	9321	1.14	80613	2 5 0		
4.6	311.86	10705	0.99	80613	2 8 0		
4	353.64	12121	0.87	80613	3 0 0		

NOTE

Other output speeds are available using 2 and 8 pole motors - Consult Application Engineering

SERIES M

SELECTION TABLES

GEARED MOTORS

5.5 kW

6 POLE

N2 R/MIN	i	M2 Nm	Fm	N	Unit Designation	Kg	Motor Size
Output Speed	Ratio	Output Torque	Service Factor	Overhung Load	Column Entry [1] Through [20] Spaces to be filled when entering order	Weight	
761	1.26	68	1.57	4600	M 0 7 1 2 1 . 2 _ M _ _ _ _ 5 . 5 C - -	78	132M
261	3.68	195	1.57	7690	M 0 7 2 2 3 . 6 _ M _ _ _ _ 5 . 5 C - -	92	132M
188	5.09	270	1.57	8020	5 . 0		
168	5.72	303	1.57	8120	5 . 6		
153	6.29	334	1.57	8180	6 . 3		
117	8.22	436	1.57	7200	8 . 0		
103	9.34	495	1.5	6720	9 . 0		
85	11.35	602	1.28	5860	1 1 .		
77	12.48	662	1.2	5320	1 2 .		
67	14.34	760	1.06	4379	1 4 .		
59	16.26	861	0.95	3369	1 6 .		
54	17.94	952	0.87	2409	1 8 .		
261	3.68	195	3.16	14328	M 0 8 2 2 3 . 6 _ M _ _ _ _ 5 . 5 C - -	125	132M
184	5.21	276	3.16	15164	5 . 0		
166	5.79	307	3.16	15442	5 . 6		
149	6.44	341	3.16	15614	6 . 3		
115	8.33	442	2.89	15800	8 . 0		
103	9.35	494	2.69	15821	9 . 0		
84	11.47	609	2.35	15777	1 1 .		
74	12.92	685	2.15	15980	1 2 .		
64	15.04	796	1.95	15225	1 4 .		
58	16.69	882	1.61	15146	1 6 .		
53	18.26	966	1.41	13651	1 8 .		
46	20.66	1094	1.33	12713	2 0 .		
41	23.32	1238	1.24	12500	2 2 .		
34	28.27	1495	1.1	12500	2 8 .		
29	32.97	1741	0.95	8500	3 2 .		
27	36.21	1914	0.86	6963	3 6 .		
66	14.53	774	3.69	25700	M 0 9 2 1 1 4 . _ M _ _ _ _ 5 . 5 C - -	166	132M
58	16.59	885	2.98	25816	1 6 .		
52	18.43	981	2.69	26386	1 8 .		
47	20.59	1100	2.6	27367	2 0 .		
42	22.87	1219	2.35	27621	2 2 .		
37	26.04	1382	1.91	26812	2 5 .		
33	28.74	1526	1.73	26437	2 8 .		
30	32.31	1715	1.55	26375	3 2 .		
27	35.67	1894	1.42	25795	3 6 .		
24	40.25	2132	1.16	26575	4 0 .		
22	44.44	2354	1.05	28690	4 5 .		
20	49.07	2595	1.07	28030	5 0 .		
32	29.99	1595	2.36	42700	M 1 0 2 1 2 8 . _ M _ _ _ _ 5 . 5 C - -	212	132M
31	30.76	1627	2.71	43141	3 2 .		
27	35.44	1880	2.35	44541	3 6 .		
26	37.06	1955	2.13	45717	4 0 .		
22	42.7	2265	1.84	47316	4 5 .		
20	47.93	2528	1.67	46245	5 0 .		
19	51.49	2714	1.43	46800	5 6 .		
17	57.75	3042	1.37	46437	6 3 .		
15	62.05	3259	1.28	46050	7 1 .		
16	60.23	3156	1.19	49200	M 1 0 3 1 5 6 . _ M _ _ _ _ 5 . 5 C - -	239	132M
14	66.93	3508	1.07	49000	6 3 .		
13	71.17	3725	1.18	48900	7 1 .		
12	79.08	4139	1.07	44490	8 0 .		
27	35.52	1867	3.4	66700	M 1 3 2 1 3 6 . _ M _ _ _ _ 5 . 5 C - -	272	132M
25	39.01	2041	3.16	66700	4 0 .		
22	43.45	2277	2.84	66600	4 5 .		
24	39.93	2094	2.84	66700	M 1 3 3 1 4 0 . _ M _ _ _ _ 5 . 5 C - -	294	132M
22	44.18	2312	2.75	66600	4 5 .		
19	50.02	2606	2.44	66500	5 0 .		
17	56.93	2991	2.07	66637	5 6 .		
15	64.17	3376	1.84	66654	6 3 .		
13	71.32	3719	1.71	66491	7 1 .		
12	80.39	4192	1.51	66391	8 0 .		
11	90.75	4729	1.31	66193	9 0 .		
9.5	101.07	5262	1.18	66062	1 0 0		
8.4	113.69	5899	1.08	65479	1 1 2		
7.6	126.62	6564	0.97	65266	1 2 5		
6.9	139.07	7192	0.9	65100	1 4 0		
6.2	154.89	8002	0.81	64833	1 6 0		
16	59.46	3098	3.58	80900	M 1 4 3 1 5 6 . _ M _ _ _ _ 5 . 5 C - -	423	132M
15	65.55	3429	3.24	80900	6 3 .		
12	78.7	4087	2.69	80900	7 1 .		
11	86.76	4514	2.44	80900	8 0 .		
10	94.35	4923	2.25	80900	9 0 .		
9.4	102.23	5308	2.09	80900	1 0 0		
7.7	124.89	6477	1.7	80900	1 1 2		
7.1	135.31	7026	1.57	80900	1 2 5		
6.7	142.66	7367	1.37	80900	1 4 0		
6.2	154.57	7992	1.26	80900	1 6 0		
5.2	185.56	9633	1.14	80900	1 8 0		
4.6	208.15	10784	1.02	80713	2 0 0		
4.5	211.96	10956	0.92	80700	2 2 5		

NOTE

Other output speeds are available using 2 and 8 pole motors - Consult Application Engineering

SERIES M

SELECTION TABLES

GEARED MOTORS

7.5 kW

4 POLE

N2 R/MIN	i	M2 Nm	Fm	N	Unit Designation	Kg	Motor Size
Output Speed	Ratio	Output Torque	Service Factor	Overhung Load	Column Entry [1] Through [20] Spaces to be filled when entering order	Weight	
393	3.68	175	1.74	7265	M 0 7 2 2 3 . 6 _ M _ _ _ _ _ 7 . 5 A _ _	92	132M
284	5.09	244	1.74	7470	5 . 0		
253	5.72	274	1.74	7415	5 . 6		
230	6.29	301	1.74	7310	6 . 3		
176	8.22	396	1.59	6860	8 . 0		
155	9.34	449	1.47	6545	9 . 0		
127	11.35	545	1.31	5134	1 . 1		
116	12.48	599	1.23	4621	1 . 2		
101	14.34	689	1.1	3952	1 . 4		
89	16.26	780	1.01	4148	1 . 6		
81	17.94	862	0.92	5440	1 . 8		
70	20.54	985	0.82	4570	2 . 0		
393	3.68	175	3.49	13458	M 0 8 2 2 3 . 6 _ M _ _ _ _ _ 7 . 5 A _ _	125	132M
277	5.21	250	3.49	13997	5 . 0		
249	5.79	278	3.49	14177	5 . 6		
224	6.44	311	3.37	14357	6 . 3		
173	8.33	402	2.91	14612	8 . 0		
155	9.35	450	2.71	14670	9 . 0		
126	11.47	550	2.38	14656	1 . 1		
112	12.92	618	2.17	14523	1 . 2		
96	15.04	726	1.95	14395	1 . 4		
87	16.69	797	1.78	13028	1 . 6		
79	18.26	874	1.55	12740	1 . 8		
70	20.66	989	1.47	12230	2 . 0		
62	23.32	1125	1.37	11635	2 . 2		
51	28.27	1352	1.18	10034	2 . 8		
44	32.97	1578	1.03	10100	3 . 2		
40	36.21	1731	0.95	8800	3 . 6		
113	12.74	615	3.93	22600	M 0 9 2 1 1 2 . _ M _ _ _ _ _ 7 . 5 A _ _	166	132M
99	14.53	702	3.6	23200	1 . 4		
87	16.59	801	3.27	23212	1 . 6		
78	18.43	886	2.98	23415	1 . 8		
70	20.59	990	2.86	24134	2 . 0		
63	22.87	1103	2.59	24702	2 . 2		
55	26.04	1249	2.11	25554	2 . 5		
50	28.74	1379	1.91	25813	2 . 8		
45	32.31	1558	1.49	26659	3 . 2		
41	35.67	1709	1.37	25925	3 . 6		
36	40.25	1932	1.28	27400	4 . 0		
33	44.44	2134	1.16	28800	4 . 5		
29	49.07	2350	1.03	28700	5 . 0		
56	26.03	1249	3.02	36300	M 1 0 2 1 2 5 . _ M _ _ _ _ _ 7 . 5 A _ _	212	132M
48	29.99	1440	2.62	37839	2 . 8		
47	30.76	1475	2.99	38185	3 . 2		
41	35.44	1702	2.59	39480	3 . 6		
39	37.06	1778	2.34	40372	4 . 0		
34	42.7	2046	2.03	42040	4 . 5		
30	47.93	2285	1.83	43318	5 . 0		
28	51.49	2468	1.57	44200	5 . 6		
25	57.75	2746	1.51	45700	6 . 3		
23	62.05	2953	1.41	46576	7 . 1		
24	60.23	2854	1.32	29100	M 1 0 3 1 5 6 . _ M _ _ _ _ _ 7 . 5 A _ _	239	132M
22	66.93	3170	1.19	29100	6 . 3		
20	71.17	3369	1.31	29100	7 . 1		
18	79.08	3741	1.18	45200	8 . 0		
15	95.44	4525	0.83	43700	9 . 0		
13	112.77	5335	0.83	42500	1 1 2		
41	35.52	1688	3.76	66500	M 1 3 2 1 3 6 . _ M _ _ _ _ _ 7 . 5 A _ _	272	132M
37	39.01	1855	3.48	66800	4 . 0		
33	43.45	2060	3.14	66700	4 . 5		
25	56.93	2692	2.3	66670	M 1 3 3 1 5 6 . _ M _ _ _ _ _ 7 . 5 A _ _	294	132M
23	64.17	3049	2.03	66779	6 . 3		
20	71.32	3365	1.89	66640	7 . 1		
18	80.39	3792	1.67	66637	8 . 0		
16	90.75	4280	1.45	66450	9 . 0		
14	101.07	4766	1.3	66300	1 0 0		
13	113.69	5339	1.19	65700	1 1 2		
11	126.62	5944	1.07	65400	1 2 5		
10	139.07	6508	0.99	65300	1 4 0		
9.3	154.89	7245	0.89	65100	1 6 0		
24	59.46	2812	3.73	66400	M 1 4 3 1 5 6 . _ M _ _ _ _ _ 7 . 5 A _ _	423	132M
22	65.55	3097	3.45	66400	6 . 3		
18	78.7	3712	2.96	66400	7 . 1		
17	86.76	4078	2.7	80900	8 . 0		
15	94.35	4443	2.5	80900	9 . 0		
14	102.23	4828	2.3	80900	1 0 0		
12	124.89	5871	1.87	80900	1 1 2		
11	135.31	6368	1.73	80900	1 2 5		
10	142.66	6667	1.51	80900	1 4 0		
9.3	154.57	7239	1.4	80900	1 6 0		
7.8	185.56	8723	1.26	80900	1 8 0		
6.9	208.15	9762	1.13	80900	2 0 0		
6.8	211.96	9923	1.02	80900	2 2 5		

NOTE

Other output speeds are available using 2 and 8 pole motors - Consult Application Engineering

SERIES M

SELECTION TABLES

GEARED MOTORS

7.5 kW

6 POLE

N2 R/MIN	i	M2 Nm	Fm	N	Unit Designation	Kg	Motor Size
Output Speed	Ratio	Output Torque	Service Factor	Overhung Load	Column Entry [1] Through [20] Spaces to be filled when entering order	Weight	
261	3.68	265	2.32	14100	M 0 8 2 2 3 . 6 _ M _ _ _ _ 7 . 5 C _ _	159	160M
184	5.21	377	2.32	14850	5 . 0		
166	5.79	419	2.32	15100	5 . 6		
149	6.44	465	2.32	15100	6 . 3		
115	8.33	603	2.12	14600	8 . 0		
103	9.35	673	1.97	14250	9 . 0		
84	11.47	831	1.72	13480	1 1 .		
74	12.92	934	1.57	13155	1 2 .		
64	15.04	1086	1.43	11965	1 4 .		
58	16.69	1203	1.18	11344	1 6 .		
53	18.26	1317	1.03	9803	1 8 .		
46	20.66	1491	0.98	8297	2 0 .		
41	23.32	1688	0.91	7954	2 2 .		
34	28.27	2038	0.81	7954	2 8 .		
117	8.22	597	3.95	22500	M 0 9 2 1 8 . 0 _ M _ _ _ _ 7 . 5 C _ _	200	160M
104	9.19	668	3.67	23000	9 . 0		
94	10.27	747	3.39	23300	1 0 .		
82	11.71	849	3.11	22983	1 1 .		
75	12.74	925	2.96	23358	1 2 .		
66	14.53	1056	2.71	24062	1 4 .		
58	16.59	1207	2.19	24105	1 6 .		
52	18.43	1337	1.97	24368	1 8 .		
47	20.59	1500	1.91	25190	2 0 .		
42	22.87	1662	1.72	25117	2 2 .		
37	26.04	1885	1.4	24662	2 5 .		
33	28.74	2082	1.27	23987	2 8 .		
30	32.31	2338	1.14	23875	3 2 .		
27	35.67	2583	1.04	22912	3 6 .		
24	40.25	2908	0.85	24802	4 0 .		
58	16.43	1193	3.16	35800	M 1 0 2 1 1 6 . _ M _ _ _ _ 7 . 5 C _ _	246	160M
53	18.25	1321	2.85	36900	1 8 .		
49	19.41	1407	3.13	37700	2 0 .		
45	21.57	1560	2.83	38800	2 2 .		
37	26.03	1885	2	40900	2 5 .		
32	29.99	2175	1.73	40566	2 8 .		
31	30.76	2219	1.99	41063	3 2 .		
27	35.44	2563	1.72	41797	3 6 .		
26	37.06	2666	1.56	43606	4 0 .		
22	42.7	3089	1.35	45650	4 5 .		
20	47.93	3447	1.22	43962	5 0 .		
19	51.49	3702	1.05	45163	5 6 .		
17	57.75	4148	1	44642	6 3 .		
15	62.05	4444	0.94	44140	7 1 .		
16	60.23	4303	0.88	49200	M 1 0 3 1 5 6 . _ M _ _ _ _ 7 . 5 C _ _	272	160M
13	71.17	5080	0.87	48900	7 1 .		
38	25.45	1830	3.39	66800	M 1 3 2 1 2 5 . _ M _ _ _ _ 7 . 5 C _ _	307	160M
34	28.35	2039	3.04	66700	2 8 .		
30	31.89	2289	2.77	66600	3 2 .		
27	35.52	2546	2.49	65973	3 6 .		
25	39.01	2784	2.32	65712	4 0 .		
22	43.45	3105	2.08	66345	4 5 .		
24	39.93	2855	2.08	66700	M 1 3 3 1 4 0 . _ M _ _ _ _ 7 . 5 C _ _	329	160M
22	44.18	3153	2.01	66600	4 5 .		
19	50.02	3554	1.79	66500	5 0 .		
17	56.93	4078	1.52	66555	5 6 .		
15	64.17	4603	1.35	66538	6 3 .		
13	71.32	5071	1.25	66325	7 1 .		
12	80.39	5717	1.11	66225	8 0 .		
11	90.75	6449	0.96	65868	9 0 .		
9.5	101.07	7175	0.86	65712	1 0 0		
24	39.42	2815	3.59	80900	M 1 4 2 1 4 0 . _ M _ _ _ _ 7 . 5 C _ _	415	160M
22	42.71	3054	3.31	80900	4 5 .		
23	41.36	2960	3.55	66400	M 1 4 3 1 4 0 . _ M _ _ _ _ 7 . 5 C _ _	460	160M
20	48.21	3423	3.21	66400	4 5 .		
18	54.75	3891	2.83	66400	5 0 .		
16	59.46	4225	2.63	80900	5 6 .		
15	65.55	4676	2.37	80900	6 3 .		
12	78.7	5574	1.97	80900	7 1 .		
11	86.76	6156	1.79	80900	8 0 .		
10	94.35	6713	1.65	80900	9 0 .		
9.4	102.23	7239	1.53	80900	1 0 0		
7.7	124.89	8832	1.25	80900	1 1 2		
7.1	135.31	9581	1.15	80900	1 2 5		
6.7	142.66	10046	1.01	80900	1 4 0		
6.2	154.57	10899	0.93	80900	1 6 0		
5.2	185.56	13136	0.84	80900	1 8 0		

NOTE

Other output speeds are available using 2 and 8 pole motors - Consult Application Engineering

SERIES M

SELECTION TABLES

GEARED MOTORS

11.0 kW

4 POLE

N2 R/MIN	i	M2 Nm	Fm	N	Unit Designation	Kg	Motor Size
Output Speed	Ratio	Output Torque	Service Factor	Overhung Load	Column Entry [1] Through [20] Spaces to be filled when entering order	Weight	
392	3.68	258	1.18	7040	M 0 7 2 2 3 . 6 _ M _ _ _ _ 1 1 . A _ _	128	160M
283	5.09	359	1.18	7160	5 . 0		
252	5.72	403	1.18	6900	5 . 6		
229	6.29	443	1.18	6570	6 . 3		
175	8.22	584	1.08	5350	8 . 0		
154	9.34	661	1	4580	9 . 0		
394	3.68	257	2.39	13197	M 0 8 2 2 3 . 6 _ M _ _ _ _ 1 1 . A _ _	159	160M
278	5.21	365	2.39	13625	5 . 0		
250	5.79	406	2.39	13768	5 . 6		
225	6.44	454	2.31	13910	6 . 3		
174	8.33	587	1.99	13346	8 . 0		
155	9.35	657	1.85	12957	9 . 0		
126	11.47	805	1.63	11998	1 1 .		
112	12.92	904	1.48	11250	1 2 .		
96	15.04	1062	1.34	10151	1 4 .		
87	16.69	1165	1.22	8656	1 6 .		
79	18.26	1278	1.06	8493	1 8 .		
70	20.66	1446	1.01	7120	2 0 .		
62	23.32	1644	0.94	5517	2 2 .		
51	28.27	1976	0.8	2284	2 8 .		
196	7.4	522	3.83	20209	M 0 9 2 1 7 . 1 _ M _ _ _ _ 1 1 . A _ _	200	160M
176	8.22	579	3.59	20624	8 . 0		
158	9.19	648	3.35	21072	9 . 0		
141	10.27	726	3.08	20720	1 0 .		
124	11.71	827	2.83	21211	1 1 .		
114	12.74	899	2.69	21464	1 2 .		
100	14.53	1026	2.46	21675	1 4 .		
87	16.59	1171	2.24	21760	1 6 .		
79	18.43	1296	2.04	21601	1 8 .		
70	20.59	1447	1.95	22170	2 0 .		
63	22.87	1613	1.77	22312	2 2 .		
56	26.04	1826	1.45	23709	2 5 .		
50	28.74	2016	1.31	23427	2 8 .		
45	32.31	2278	1.02	24018	3 2 .		
41	35.67	2499	0.94	23066	3 6 .		
36	40.25	2824	0.87	25688	4 0 .		
88	16.43	1155	3.26	32215	M 1 0 2 1 1 6 . _ M _ _ _ _ 1 1 . A _ _	246	160M
79	18.25	1283	2.94	32896	1 8 .		
75	19.41	1382	3.24	33324	2 0 .		
67	21.57	1515	2.91	32667	2 2 .		
56	26.03	1826	2.06	35310	2 5 .		
48	29.99	2105	1.79	36623	2 8 .		
47	30.76	2156	2.05	37054	3 2 .		
41	35.44	2487	1.77	37602	3 6 .		
39	37.06	2600	1.6	39044	4 0 .		
34	42.7	2990	1.39	40481	4 5 .		
30	47.93	3339	1.25	41536	5 0 .		
28	51.49	3607	1.07	42333	5 6 .		
25	57.75	4014	1.04	43600	6 3 .		
23	62.05	4316	0.96	44339	7 1 .		
24	60.23	4172	0.9	28788	M 1 0 3 1 5 6 . _ M _ _ _ _ 1 1 . A _ _	272	160M
22	66.93	4633	0.81	28788	6 3 .		
20	71.17	4924	0.9	28788	7 1 .		
57	25.45	1780	3.48	60039	M 1 3 2 1 2 5 . _ M _ _ _ _ 1 1 . A _ _	307	160M
51	28.35	1982	3.13	61744	2 8 .		
45	31.89	2224	2.85	63271	3 2 .		
41	35.52	2468	2.57	65208	3 6 .		
37	39.01	2712	2.38	65228	4 0 .		
33	43.45	3011	2.15	66000	4 5 .		
36	39.93	2777	1.99	50560	M 1 3 3 1 4 0 . _ M _ _ _ _ 1 1 . A _ _	329	160M
33	44.18	3057	2.02	50560	4 5 .		
29	50.02	3453	1.83	50560	5 0 .		
25	56.93	3935	1.57	66616	5 6 .		
23	64.17	4457	1.39	66658	6 3 .		
20	71.32	4919	1.29	66481	7 1 .		
18	80.39	5543	1.15	66433	8 0 .		
16	90.75	6256	0.99	66100	9 0 .		
14	101.07	6966	0.89	65988	1 0 0		
37	39.42	2740	3.63	80924	M 1 4 2 1 4 0 . _ M _ _ _ _ 1 1 . A _ _	415	160M
34	42.71	2964	3.37	80900	4 5 .		
35	41.36	2857	3.41	66432	M 1 4 3 1 4 0 . _ M _ _ _ _ 1 1 . A _ _	460	160M
30	48.21	3324	3.31	66432	4 5 .		
26	54.75	3769	2.92	66432	5 0 .		
24	59.46	4110	2.55	66275	5 6 .		
22	65.55	4526	2.36	66275	6 3 .		
18	78.7	5426	2.03	66206	7 1 .		
17	86.76	5960	1.85	80900	8 0 .		
15	94.35	6494	1.71	80900	9 0 .		
14	102.23	7057	1.57	80900	1 0 0		
12	124.89	8581	1.28	80900	1 1 2		
11	135.31	9307	1.18	80900	1 2 5		
10	142.66	9745	1.04	80900	1 4 0		
9.4	154.57	10580	0.95	80900	1 6 0		

NOTE

Other output speeds are available using 2 and 8 pole motors - Consult Application Engineering

SERIES M

SELECTION TABLES

GEARED MOTORS

11.0 kW

6 POLE

N2 R/MIN	i	M2 Nm	Fm	N	Unit Designation	Kg	Motor Size
Output Speed	Ratio	Output Torque	Service Factor	Overhung Load	Column Entry [1] Through [20] Spaces to be filled when entering order	Weight	
262	3.68	388	1.59	13700	M 0 8 2 2 3 . 6 _ M _ _ _ _ 1 1 . C - -	173	160L
185	5.21	550	1.59	14300	5 . 0		
167	5.79	611	1.59	14500	5 . 6		
150	6.44	679	1.59	14200	6 . 3		
116	8.33	880	1.45	12500	8 . 0		
103	9.35	983	1.35	11500	9 . 0		
84	11.47	1213	1.18	9460	1 1 .		
75	12.92	1363	1.08	8210	1 2 .		
64	15.04	1585	0.98	6260	1 4 .		
58	16.69	1755	0.81	4690	1 6 .		
262	3.69	394	2.76	19200	M 0 9 2 1 3 . 6 _ M _ _ _ _ 1 1 . C - -	214	160L
211	4.58	488	3.89	20000	4 . 5		
190	5.07	538	3.67	20400	5 . 0		
170	5.69	602	3.42	20800	5 . 6		
146	6.63	702	3.09	21200	6 . 3		
130	7.4	785	2.88	21135	7 . 1		
117	8.22	872	2.7	21442	8 . 0		
105	9.19	974	2.51	21615	9 . 0		
94	10.27	1089	2.32	21371	1 0 .		
82	11.71	1239	2.13	20678	1 1 .		
76	12.74	1350	2.03	21011	1 2 .		
66	14.53	1541	1.86	21196	1 4 .		
58	16.59	1761	1.5	21111	1 6 .		
52	18.43	1951	1.35	20837	1 8 .		
47	20.59	2188	1.31	21381	2 0 .		
42	22.87	2426	1.18	20734	2 2 .		
37	26.04	2751	0.96	20900	2 5 .		
34	28.74	3037	0.87	19700	2 8 .		
91	10.59	1121	3.36	32000	M 1 0 2 1 1 0 . _ M _ _ _ _ 1 1 . C - -	260	160L
81	11.98	1269	2.97	32600	1 1 .		
77	12.51	1322	3.33	32900	1 2 .		
68	14.16	1498	2.94	33600	1 4 .		
59	16.43	1740	2.17	33980	1 6 .		
53	18.25	1927	1.96	34597	1 8 .		
50	19.41	2053	2.15	35273	2 0 .		
45	21.57	2276	1.94	35797	2 2 .		
37	26.03	2750	1.37	37882	2 5 .		
32	29.99	3173	1.19	36833	2 8 .		
31	30.76	3238	1.36	37427	3 2 .		
27	35.44	3740	1.18	36994	3 6 .		
26	37.06	3890	1.07	39913	4 0 .		
23	42.7	4507	0.92	42733	4 5 .		
20	47.93	5030	0.84	39966	5 0 .		
54	18	1900	3.26	60900	M 1 3 2 1 1 8 . _ M _ _ _ _ 1 1 . C - -	321	160L
48	20	2105	3.02	62800	2 0 .		
43	22.55	2371	2.68	64800	2 2 .		
38	25.45	2671	2.32	64812	2 5 .		
34	28.35	2975	2.08	64896	2 8 .		
30	31.89	3340	1.9	64772	3 2 .		
27	35.52	3715	1.71	64702	3 6 .		
25	39.01	4062	1.59	63983	4 0 .		
22	43.45	4531	1.43	65900	4 5 .		
24	39.93	4166	1.43	66700	M 1 3 3 1 4 0 . _ M _ _ _ _ 1 1 . C - -	343	160L
22	44.18	4601	1.38	66600	4 5 .		
19	50.02	5185	1.22	66500	5 0 .		
17	56.93	5951	1.04	66410	5 6 .		
15	64.17	6717	0.92	66335	6 3 .		
14	71.32	7400	0.86	66033	7 1 .		
34	28.25	2967	3.36	80900	M 1 4 2 1 2 8 . _ M _ _ _ _ 1 1 . C - -	429	160L
28	34.51	3625	2.95	80900	3 2 .		
26	37.39	3913	2.76	80900	3 6 .		
24	39.42	4108	2.46	80853	4 0 .		
23	42.71	4456	2.27	80864	4 5 .		
23	41.36	4319	2.43	66135	M 1 4 3 1 4 0 . _ M _ _ _ _ 1 1 . C - -	474	160L
20	48.21	4994	2.2	66135	4 5 .		
18	54.75	5677	1.94	66135	5 0 .		
16	59.46	6165	1.8	80900	5 6 .		
15	65.55	6824	1.63	80900	6 3 .		
12	78.7	8133	1.35	80900	7 1 .		
11	86.76	8983	1.22	80900	8 0 .		
10	94.35	9795	1.13	80900	9 0 .		
9.4	102.23	10562	1.05	80900	1 0 0		
7.7	124.89	12887	0.85	80900	1 1 2		

NOTE

Other output speeds are available using 2 and 8 pole motors - Consult Application Engineering

SERIES M

SELECTION TABLES

GEARED MOTORS

15.0 kW

4 POLE

N2 R/MIN	i	M2 Nm	Fm	N	Unit Designation	Kg	Motor Size
Output Speed	Ratio	Output Torque	Service Factor	Overhung Load	Column Entry [1] Through [20] Spaces to be filled when entering order	Weight	
396	3.68	349	1.76	12900	M 0 8 2 2 3 . 6 _ M _ _ _ _ 1 5 . A _ _	173	160L
279	5.21	496	1.76	13200	5 . 0		
251	5.79	552	1.76	13300	5 . 6		
226	6.44	617	1.7	13400	6 . 3		
175	8.33	798	1.47	11900	8 . 0		
156	9.35	893	1.36	11000	9 . 0		
127	11.47	1093	1.2	8959	1 1 .		
113	12.92	1228	1.09	7509	1 2 .		
97	15.04	1444	0.98	5299	1 4 .		
87	16.69	1584	0.9	3659	1 6 .		
441	3.3	319	3.41	17400	M 0 9 2 1 3 . 2 _ M _ _ _ _ 1 5 . A _ _	214	160L
394	3.69	356	3.06	18000	3 . 6		
318	4.58	440	3.81	18700	4 . 5		
287	5.07	487	3.59	18900	5 . 0		
256	5.69	544	3.34	19200	5 . 6		
220	6.63	636	3.02	19500	6 . 3		
197	7.4	710	2.82	19772	7 . 1		
177	8.22	787	2.64	20127	8 . 0		
158	9.19	881	2.46	20381	9 . 0		
142	10.27	987	2.27	19486	1 0 .		
124	11.71	1124	2.08	19966	1 1 .		
114	12.74	1222	1.98	20166	1 2 .		
100	14.53	1395	1.81	19933	1 4 .		
88	16.59	1592	1.65	20102	1 6 .		
79	18.43	1761	1.5	19528	1 8 .		
71	20.59	1967	1.44	19926	2 0 .		
64	22.87	2192	1.3	19580	2 2 .		
56	26.04	2482	1.06	21600	2 5 .		
51	28.74	2740	0.96	20700	2 8 .		
137	10.59	1014	3.63	29400	M 1 0 2 1 1 0 . _ M _ _ _ _ 1 5 . A _ _	260	160L
121	11.98	1147	3.28	30000	1 1 .		
116	12.51	1196	3.25	30200	1 2 .		
103	14.16	1351	3	30954	1 4 .		
89	16.43	1569	2.4	31354	1 6 .		
80	18.25	1744	2.16	31312	1 8 .		
75	19.41	1851	2.38	31628	2 0 .		
67	21.57	2060	2.14	30688	2 2 .		
56	26.03	2482	1.52	34179	2 5 .		
49	29.99	2860	1.32	35232	2 8 .		
47	30.76	2929	1.51	35762	3 2 .		
41	35.44	3380	1.3	35456	3 6 .		
39	37.06	3533	1.18	37527	4 0 .		
34	42.7	4064	1.02	38700	4 5 .		
30	47.93	4538	0.92	39500	5 0 .		
81	18	1719	3.61	55200	M 1 3 2 1 1 8 . _ M _ _ _ _ 1 5 . A _ _	321	160L
73	20	1902	3.34	56100	2 0 .		
65	22.55	2142	2.96	56772	2 2 .		
57	25.45	2419	2.56	58681	2 5 .		
51	28.35	2694	2.3	60368	2 8 .		
46	31.89	3023	2.1	61752	3 2 .		
41	35.52	3354	1.89	63733	3 6 .		
37	39.01	3685	1.75	63433	4 0 .		
33	43.45	4091	1.58	65200	4 5 .		
36	39.93	3774	1.47	49920	M 1 3 3 1 4 0 . _ M _ _ _ _ 1 5 . A _ _	343	160L
33	44.18	4154	1.49	49920	4 5 .		
29	50.02	4692	1.34	49920	5 0 .		
26	56.93	5348	1.16	66554	5 6 .		
23	64.17	6057	1.02	66520	6 3 .		
20	71.32	6684	0.95	66300	7 1 .		
18	80.39	7533	0.84	66200	8 0 .		
52	28.25	2680	3.72	79400	M 1 4 2 1 2 8 . _ M _ _ _ _ 1 5 . A _ _	429	160L
42	34.51	3277	3.26	80900	3 2 .		
39	37.39	3540	3.05	80900	3 6 .		
37	39.42	3724	2.67	80827	4 0 .		
34	42.71	4029	2.48	80900	4 5 .		
35	41.36	3882	2.51	66304	M 1 4 3 1 4 0 . _ M _ _ _ _ 1 5 . A _ _	474	160L
30	48.21	4517	2.44	66304	4 5 .		
27	54.75	5122	2.15	66304	5 0 .		
24	59.46	5585	1.88	66133	5 6 .		
22	65.55	6151	1.74	66133	6 3 .		
18	78.7	7373	1.49	65986	7 1 .		
17	86.76	8100	1.36	80900	8 0 .		
15	94.35	8825	1.26	80900	9 0 .		
14	102.23	9591	1.16	80900	1 0 0		
12	124.89	11661	0.94	80900	1 1 2		
11	135.31	12648	0.87	80900	1 2 5		

NOTE

Other output speeds are available using 2 and 8 pole motors - Consult Application Engineering

SERIES M

SELECTION TABLES

GEARED MOTORS

15.0 kW

6 POLE

N2 R/MIN	i	M2 Nm	Fm	N	Unit Designation	Kg	Motor Size
Output Speed	Ratio	Output Torque	Service Factor	Overhung Load	Column Entry [1] Through [20] Spaces to be filled when entering order	Weight	
656	1.48	213	3.49	15400	M 0 9 2 1 1 . 4 _ M _ _ _ _ 1 5 . C _ _	313	180L
476	2.04	295	3.49	17100	1 . 8		
425	2.28	331	3.29	17700	2 . 2		
379	2.56	371	2.93	18200	2 . 5		
327	2.97	427	3.49	18600	2 . 8		
294	3.3	478	2.28	18700	3 . 2		
263	3.69	535	2.03	18884	3 . 6		
237	4.09	587	3.08	19305	4 . 0		
212	4.58	662	2.87	19663	4 . 5		
191	5.07	731	2.71	20042	5 . 0		
171	5.69	817	2.52	20400	5 . 6		
146	6.63	953	2.28	20336	6 . 3		
131	7.4	1065	2.12	20033	7 . 1		
118	8.22	1183	1.99	20233	8 . 0		
106	9.19	1322	1.85	20033	9 . 0		
94	10.27	1478	1.71	19166	1 0 .		
83	11.71	1682	1.57	18045	1 1 .		
76	12.74	1832	1.5	18329	1 2 .		
67	14.53	2091	1.37	17921	1 4 .		
58	16.59	2389	1.1	17688	1 6 .		
53	18.43	2648	1	16802	1 8 .		
47	20.59	2969	0.96	17028	2 0 .		
42	22.87	3291	0.87	15725	2 2 .		
443	2.19	315	3.49	23700	M 1 0 2 1 2 . 2 _ M _ _ _ _ 1 5 . C _ _	359	180L
390	2.49	358	3.49	24700	2 . 5		
324	2.99	429	3.49	26000	2 . 8		
299	3.24	468	3.35	26100	3 . 2		
277	3.5	505	3.11	26300	3 . 6		
232	4.18	598	3.49	27100	4 . 0		
213	4.55	653	3.49	27300	4 . 5		
196	4.94	707	3.49	27700	5 . 0		
181	5.37	770	3.49	28100	5 . 6		
144	6.72	965	3.49	29200	6 . 3		
134	7.26	1043	3.49	29500	7 . 1		
122	7.95	1139	3.3	30000	8 . 0		
113	8.58	1230	3.15	30400	9 . 0		
92	10.59	1520	2.48	31305	1 0 .		
81	11.98	1722	2.19	31821	1 1 .		
78	12.51	1794	2.45	32100	1 2 .		
68	14.16	2033	2.17	32315	1 4 .		
59	16.43	2361	1.6	31900	1 6 .		
53	18.25	2615	1.44	31966	1 8 .		
50	19.41	2785	1.58	32500	2 0 .		
45	21.57	3088	1.43	32366	2 2 .		
37	26.03	3731	1.01	34434	2 5 .		
32	29.99	4305	0.88	32566	2 8 .		
32	30.76	4393	1	33272	3 2 .		
27	35.44	5075	0.87	31505	3 6 .		
78	12.39	1771	3.58	55600	M 1 3 2 1 1 2 . _ M _ _ _ _ 1 5 . C _ _	419	180L
69	14.03	2008	3.13	56600	1 4 .		
61	15.97	2289	2.71	58200	1 6 .		
54	18	2578	2.4	59209	1 8 .		
48	20	2856	2.22	60900	2 0 .		
43	22.55	3217	1.97	62554	2 2 .		
38	25.45	3623	1.71	62540	2 5 .		
34	28.35	4036	1.54	62835	2 8 .		
30	31.89	4532	1.4	62684	3 2 .		
27	35.52	5041	1.26	63248	3 6 .		
25	39.01	5511	1.17	62008	4 0 .		
22	43.45	6147	1.05	65390	4 5 .		
24	39.93	5652	1.05	66700	M 1 3 3 1 4 0 . _ M _ _ _ _ 1 5 . C _ _	441	180L
22	44.18	6242	1.02	66600	4 5 .		
19	50.02	7034	0.9	66500	5 0 .		
40	23.97	3425	3.15	80900	M 1 4 2 1 2 2 . _ M _ _ _ _ 1 5 . C _ _	529	180L
37	26.07	3728	2.84	80900	2 5 .		
34	28.25	4025	2.48	79745	2 8 .		
28	34.51	4917	2.18	79109	3 2 .		
26	37.39	5308	2.03	78890	3 6 .		
25	39.42	5573	1.81	80800	4 0 .		
23	42.71	6045	1.67	80823	4 5 .		
23	41.36	5860	1.79	65833	M 1 4 3 1 4 0 . _ M _ _ _ _ 1 5 . C _ _	574	180L
20	48.21	6775	1.62	65833	4 5 .		
18	54.75	7702	1.43	65833	5 0 .		
16	59.46	8364	1.33	80900	5 6 .		
15	65.55	9257	1.2	80900	6 3 .		
12	78.7	11033	1	80900	7 1 .		
11	86.76	12186	0.9	80900	8 0 .		
10	94.35	13288	0.84	80900	9 0 .		

NOTE

Other output speeds are available using 2 and 8 pole motors - Consult Application Engineering

SERIES M

SELECTION TABLES

GEARED MOTORS

18.5 kW

4 POLE

N2 R/MIN	i	M2 Nm	Fm	N	Unit Designation	Kg	Motor Size
Output Speed	Ratio	Output Torque	Service Factor	Overhung Load	Column Entry [1] Through [20] Spaces to be filled when entering order	Weight	
574	2.56	299	3.6	16006	M 0 9 2 1 2 . 5 _ M _ _ _ _ 1 8 . A _ _	299	180M
445	3.3	390	2.79	17283	3 . 2		
399	3.69	435	2.5	17871	3 . 6		
360	4.09	477	3.35	18271	4 . 0		
321	4.58	537	3.12	18560	4 . 5		
290	5.07	594	2.94	18760	5 . 0		
259	5.69	664	2.74	19025	5 . 6		
222	6.63	776	2.47	19255	6 . 3		
199	7.4	866	2.31	19390	7 . 1		
179	8.22	960	2.16	19692	8 . 0		
160	9.19	1076	2.02	19777	9 . 0		
143	10.27	1205	1.86	18406	1 0 .		
126	11.71	1373	1.7	18877	1 1 .		
115	12.74	1491	1.62	19031	1 2 .		
101	14.53	1703	1.49	18408	1 4 .		
89	16.59	1943	1.35	18651	1 6 .		
80	18.43	2150	1.23	17714	1 8 .		
71	20.59	2401	1.18	17963	2 0 .		
64	22.87	2676	1.07	17190	2 2 .		
202	7.26	847	3.8	27300	M 1 0 2 1 7 . 1 _ M _ _ _ _ 1 8 . A _ _	345	180M
185	7.95	927	3.59	27700	8 . 0		
171	8.58	1000	3.42	28166	9 . 0		
139	10.59	1238	2.97	29096	1 0 .		
123	11.98	1401	2.69	29661	1 1 .		
118	12.51	1460	2.66	29861	1 2 .		
104	14.16	1649	2.46	30551	1 4 .		
89	16.43	1916	1.97	30601	1 6 .		
81	18.25	2129	1.77	29926	1 8 .		
76	19.41	2260	1.95	30144	2 0 .		
68	21.57	2514	1.75	28955	2 2 .		
56	26.03	3030	1.24	33189	2 5 .		
49	29.99	3492	1.08	34016	2 8 .		
48	30.76	3576	1.23	34631	3 2 .		
41	35.44	4126	1.07	33578	3 6 .		
40	37.06	4313	0.96	36200	4 0 .		
105	14.03	1632	3.85	52700	M 1 3 2 1 1 4 . _ M _ _ _ _ 1 8 . A _ _	405	180M
92	15.97	1860	3.33	53508	1 6 .		
82	18	2099	2.95	54351	1 8 .		
73	20	2322	2.73	55137	2 0 .		
65	22.55	2615	2.43	55689	2 2 .		
58	25.45	2954	2.1	57493	2 5 .		
52	28.35	3288	1.89	59164	2 8 .		
46	31.89	3690	1.72	60423	3 2 .		
41	35.52	4094	1.55	62442	3 6 .		
38	39.01	4499	1.44	61862	4 0 .		
34	43.45	4995	1.29	64500	4 5 .		
37	39.93	4607	1.2	49360	M 1 3 3 1 4 0 . _ M _ _ _ _ 1 8 . A _ _	427	180M
33	44.18	5071	1.22	49360	4 5 .		
29	50.02	5728	1.1	49360	5 0 .		
26	56.93	6529	0.95	66500	5 6 .		
23	64.17	7394	0.84	66400	6 3 .		
61	23.97	2787	3.87	75200	M 1 4 2 1 2 2 . _ M _ _ _ _ 1 8 . A _ _	515	180M
56	26.07	3003	3.5	77000	2 5 .		
52	28.25	3272	3.05	78603	2 8 .		
43	34.51	4001	2.67	79736	3 2 .		
39	37.39	4321	2.5	79675	3 6 .		
37	39.42	4546	2.19	80742	4 0 .		
34	42.71	4918	2.03	80900	4 5 .		
36	41.36	4739	2.05	66192	M 1 4 3 1 4 0 . _ M _ _ _ _ 1 8 . A _ _	560	180M
30	48.21	5514	1.99	66192	4 5 .		
27	54.75	6253	1.76	66192	5 0 .		
25	59.46	6818	1.54	66008	5 6 .		
22	65.55	7509	1.42	66008	6 3 .		
19	78.7	9001	1.22	65793	7 1 .		
17	86.76	9888	1.11	80900	8 0 .		
16	94.35	10774	1.03	80900	9 0 .		
14	102.23	11708	0.95	80900	1 0 0		

NOTE

Other output speeds are available using 2 and 8 pole motors - Consult Application Engineering

SERIES M

SELECTION TABLES

GEARED MOTORS

18.5 kW

6 POLE

N2 R/MIN	i	M2 Nm	Fm	N	Unit Designation	Kg	Motor Size
Output Speed	Ratio	Output Torque	Service Factor	Overhung Load	Column Entry [1] Through [20] Spaces to be filled when entering order	Weight	
659	1.48	261	2.84	15306	M 0 9 2 1 1 . 4 _ M _ _ _ _ 1 8 . C _ _	368	200L
479	2.04	362	2.84	16936	1 . 8		
427	2.28	406	2.68	17513	2 . 2		
381	2.56	456	2.39	18013	2 . 5		
328	2.97	523	2.84	18413	2 . 8		
295	3.3	587	1.86	18443	3 . 2		
264	3.69	657	1.66	18607	3 . 6		
239	4.09	721	2.51	19047	4 . 0		
213	4.58	812	2.34	19368	4 . 5		
192	5.07	897	2.21	19728	5 . 0		
171	5.69	1003	2.05	20050	5 . 6		
147	6.63	1169	1.86	19581	6 . 3		
132	7.4	1306	1.73	19068	7 . 1		
119	8.22	1452	1.62	19175	8 . 0		
106	9.19	1622	1.51	18648	9 . 0		
95	10.27	1814	1.39	17237	1 0 .		
83	11.71	2063	1.28	15741	1 1 .		
77	12.74	2248	1.22	15982	1 2 .		
67	14.53	2566	1.11	15055	1 4 .		
59	16.59	2932	0.9	14694	1 6 .		
53	18.43	3249	0.81	13271	1 8 .		
676	1.44	253	2.84	20700	M 1 0 2 1 1 . 4 _ M _ _ _ _ 1 8 . C _ _	414	200L
484	2.01	355	2.84	23000	1 . 8		
445	2.19	386	2.84	23560	2 . 2		
392	2.49	439	2.84	24536	2 . 5		
326	2.99	527	2.84	25813	2 . 8		
301	3.24	574	2.73	25866	3 . 2		
279	3.5	620	2.53	26066	3 . 6		
233	4.18	734	2.84	26843	4 . 0		
215	4.55	801	2.84	27043	4 . 5		
197	4.94	868	2.84	27420	5 . 0		
182	5.37	945	2.84	27796	5 . 6		
145	6.72	1185	2.84	28803	6 . 3		
134	7.26	1280	2.84	29080	7 . 1		
123	7.95	1397	2.69	29556	8 . 0		
114	8.58	1509	2.56	29910	9 . 0		
92	10.59	1866	2.02	30697	1 0 .		
81	11.98	2112	1.78	31139	1 1 .		
78	12.51	2201	2	31400	1 2 .		
69	14.16	2494	1.77	31192	1 4 .		
59	16.43	2897	1.3	30080	1 6 .		
53	18.25	3208	1.17	29664	1 8 .		
50	19.41	3418	1.29	30073	2 0 .		
45	21.57	3789	1.16	29364	2 2 .		
37	26.03	4578	0.82	31417	2 5 .		
32	30.76	5391	0.82	29636	3 2 .		
336	2.9	510	3.41	44500	M 1 3 2 1 2 . 8 _ M _ _ _ _ 1 8 . C _ _	475	200L
306	3.19	560	3.41	45000	3 . 2		
268	3.64	639	3.41	45700	3 . 6		
242	4.03	709	3.41	46300	4 . 0		
221	4.42	780	3.41	46800	4 . 5		
193	5.04	885	3.41	47600	5 . 0		
176	5.54	973	3.41	48400	5 . 6		
157	6.21	1094	3.41	49300	6 . 3		
142	6.88	1214	3.41	50100	7 . 1		
125	7.78	1366	3.41	51200	8 . 0		
113	8.62	1513	3.41	52000	9 . 0		
99	9.89	1742	3.41	53100	1 0 .		
87	11.2	1978	3	54200	1 1 .		
79	12.39	2174	2.92	54733	1 2 .		
69	14.03	2463	2.55	55550	1 4 .		
61	15.97	2809	2.21	56896	1 6 .		
54	18	3163	1.96	57729	1 8 .		
49	20	3505	1.81	59237	2 0 .		
43	22.55	3947	1.61	60589	2 2 .		
38	25.45	4446	1.39	60552	2 5 .		
34	28.35	4953	1.25	61032	2 8 .		
31	31.89	5560	1.14	60857	3 2 .		
27	35.52	6185	1.03	61977	3 6 .		
25	39.01	6762	0.96	60279	4 0 .		
22	43.45	7543	0.86	64945	4 5 .		
24	39.93	6935	0.86	66700	M 1 3 3 1 4 0 . _ M _ _ _ _ 1 8 . C _ _	497	200L
22	44.18	7660	0.83	66600	4 5 .		
54	18.11	3174	3.5	78000	M 1 4 2 1 1 8 . _ M _ _ _ _ 1 8 . C _ _	586	200L
45	21.75	3808	2.78	80900	2 0 .		
41	23.97	4203	2.57	79692	2 2 .		
37	26.07	4575	2.32	79867	2 5 .		
35	28.25	4939	2.02	78735	2 8 .		
28	34.51	6034	1.77	77542	3 2 .		
26	37.39	6514	1.66	77132	3 6 .		
25	39.42	6839	1.48	80753	4 0 .		
23	42.71	7418	1.36	80788	4 5 .		
24	41.36	7190	1.46	65568	M 1 4 3 1 4 0 . _ M _ _ _ _ 1 8 . C _ _	631	200L
20	48.21	8314	1.32	65568	4 5 .		
18	54.75	9451	1.16	65568	5 0 .		
16	59.46	10263	1.08	80900	5 6 .		
15	65.55	11359	0.98	80900	6 3 .		
12	78.7	13538	0.81	80900	7 1 .		

NOTE

Other output speeds are available using 2 and 8 pole motors - Consult Application Engineering

SERIES M

SELECTION TABLES

GEARED MOTORS

22.0 kW

4 POLE

N2 R/MIN	i	M2 Nm	Fm	N	Unit Designation	Kg	Motor Size
Output Speed	Ratio	Output Torque	Service Factor	Overhung Load	Column Entry [1] Through [20] Spaces to be filled when entering order	Weight	
994	1.48	206	3.6	13447	M 0 9 2 1 1 . 4 - M - - - - 2 2 . A - -	313	180L
722	2.04	284	3.5	14860	1 . 8		
644	2.28	318	3.39	15413	2 . 2		
574	2.56	356	3.03	15913	2 . 5		
495	2.97	412	3.4	16813	2 . 8		
445	3.3	463	2.35	17166	3 . 2		
399	3.69	517	2.11	17743	3 . 6		
360	4.09	568	2.82	18143	4 . 0		
321	4.58	639	2.63	18420	4 . 5		
290	5.07	707	2.47	18620	5 . 0		
259	5.69	789	2.3	18850	5 . 6		
222	6.63	923	2.08	19010	6 . 3		
199	7.4	1030	1.94	19009	7 . 1		
179	8.22	1142	1.82	19257	8 . 0		
160	9.19	1279	1.7	19172	9 . 0		
143	10.27	1433	1.56	17327	1 0 .		
126	11.71	1632	1.43	17788	1 1 .		
115	12.74	1774	1.36	17895	1 2 .		
101	14.53	2025	1.25	16884	1 4 .		
89	16.59	2311	1.13	17200	1 6 .		
80	18.43	2557	1.03	15899	1 8 .		
71	20.59	2856	0.99	15999	2 0 .		
64	22.87	3182	0.9	14800	2 2 .		
1019	1.44	200	3.6	18100	M 1 0 2 1 1 . 4 - M - - - - 2 2 . A - -	359	180L
730	2.01	280	3.6	20100	1 . 8		
671	2.19	305	3.6	20600	2 . 2		
591	2.49	346	3.6	21400	2 . 5		
491	2.99	413	3.6	22800	2 . 8		
453	3.24	451	3.39	23300	3 . 2		
420	3.5	488	3.19	23800	3 . 6		
352	4.18	579	3.6	25300	4 . 0		
323	4.55	632	3.6	25600	4 . 5		
298	4.94	685	3.6	25900	5 . 0		
274	5.37	746	3.6	26200	5 . 6		
219	6.72	934	3.36	26800	6 . 3		
202	7.26	1008	3.19	27101	7 . 1		
185	7.95	1103	3.02	27501	8 . 0		
171	8.58	1189	2.88	27933	9 . 0		
139	10.59	1473	2.5	28793	1 0 .		
123	11.98	1666	2.26	29323	1 1 .		
118	12.51	1736	2.24	29523	1 2 .		
104	14.16	1961	2.06	30148	1 4 .		
89	16.43	2278	1.65	29848	1 6 .		
81	18.25	2532	1.49	28540	1 8 .		
76	19.41	2688	1.64	28660	2 0 .		
68	21.57	2990	1.47	27223	2 2 .		
56	26.03	3604	1.05	32200	2 5 .		
49	29.99	4152	0.91	32800	2 8 .		
48	30.76	4253	1.04	33500	3 2 .		
41	35.44	4907	0.9	31700	3 6 .		
131	11.2	1558	3.81	50400	M 1 3 2 1 1 1 . - M - - - - 2 2 . A - -	419	180L
119	12.39	1716	3.7	51300	1 2 .		
105	14.03	1941	3.24	52018	1 4 .		
92	15.97	2212	2.8	52817	1 6 .		
82	18	2496	2.48	53502	1 8 .		
73	20	2761	2.3	54175	2 0 .		
65	22.55	3110	2.04	54606	2 2 .		
58	25.45	3512	1.76	56306	2 5 .		
52	28.35	3911	1.59	57960	2 8 .		
46	31.89	4388	1.45	59094	3 2 .		
41	35.52	4869	1.3	61151	3 6 .		
38	39.01	5350	1.21	60291	4 0 .		
34	43.45	5940	1.09	63800	4 5 .		
37	39.93	5479	1.01	48800	M 1 3 3 1 4 0 . - M - - - - 2 2 . A - -	441	180L
33	44.18	6031	1.02	48800	4 5 .		
29	50.02	6812	0.93	48800	5 0 .		
68	21.75	2999	3.53	73600	M 1 4 2 1 2 0 . - M - - - - 2 2 . A - -	529	180L
61	23.97	3314	3.26	74382	2 2 .		
56	26.07	3571	2.94	75965	2 5 .		
52	28.25	3891	2.56	77807	2 8 .		
43	34.51	4758	2.25	78572	3 2 .		
39	37.39	5139	2.1	78450	3 6 .		
37	39.42	5406	1.84	80657	4 0 .		
34	42.71	5849	1.71	80900	4 5 .		
36	41.36	5636	1.73	66080	M 1 4 3 1 4 0 . - M - - - - 2 2 . A - -	574	180L
30	48.21	6557	1.68	66080	4 5 .		
27	54.75	7436	1.48	66080	5 0 .		
25	59.46	8108	1.29	65884	5 6 .		
22	65.55	8930	1.2	65884	6 3 .		
19	78.7	10704	1.03	65600	7 1 .		
17	86.76	11758	0.94	80900	8 0 .		
16	94.35	12812	0.87	80900	9 0 .		

NOTE

Other output speeds are available using 2 and 8 pole motors - Consult Application Engineering

SERIES M

SELECTION TABLES

GEARED MOTORS

22.0 kW

6 POLE

N2 R/MIN	i	M2 Nm	Fm	N	Unit Designation	Kg	Motor Size
Output Speed	Ratio	Output Torque	Service Factor	Overhung Load	Column Entry [1] Through [20] Spaces to be filled when entering order	Weight	
659	1.48	311	2.39	15213	M 0 9 2 1 1 . 4 _ M _ _ _ _ 2 2 . C - -	368	200L
479	2.04	430	2.39	16773	1 . 8		
427	2.28	483	2.25	17326	2 . 2		
381	2.56	542	2.01	17826	2 . 5		
328	2.97	623	2.39	18226	2 . 8		
295	3.3	698	1.56	18186	3 . 2		
264	3.69	781	1.39	18331	3 . 6		
239	4.09	857	2.11	18789	4 . 0		
213	4.58	966	1.97	19073	4 . 5		
192	5.07	1066	1.86	19415	5 . 0		
171	5.69	1193	1.73	19700	5 . 6		
147	6.63	1390	1.56	18826	6 . 3		
132	7.4	1554	1.45	18104	7 . 1		
119	8.22	1727	1.37	18117	8 . 0		
106	9.19	1929	1.27	17264	9 . 0		
95	10.27	2157	1.17	15308	1 0 .		
83	11.71	2454	1.08	13436	1 1 .		
77	12.74	2673	1.02	13634	1 2 .		
67	14.53	3051	0.94	12190	1 4 .		
676	1.44	301	2.39	20578	M 1 0 2 1 1 . 4 _ M _ _ _ _ 2 2 . C - -	414	200L
484	2.01	422	2.39	22847	1 . 8		
445	2.19	459	2.39	23420	2 . 2		
392	2.49	522	2.39	24373	2 . 5		
326	2.99	627	2.39	25626	2 . 8		
301	3.24	682	2.3	25633	3 . 2		
279	3.5	737	2.13	25833	3 . 6		
233	4.18	873	2.39	26586	4 . 0		
215	4.55	953	2.39	26786	4 . 5		
197	4.94	1032	2.39	27140	5 . 0		
182	5.37	1124	2.39	27493	5 . 6		
145	6.72	1409	2.39	28406	6 . 3		
134	7.26	1522	2.39	28660	7 . 1		
123	7.95	1662	2.26	29113	8 . 0		
114	8.58	1795	2.16	29420	9 . 0		
92	10.59	2219	1.7	30089	1 0 .		
81	11.98	2512	1.5	30457	1 1 .		
78	12.51	2618	1.68	30700	1 2 .		
69	14.16	2966	1.49	30068	1 4 .		
336	2.9	606	2.87	44375	M 1 3 2 1 2 . 8 _ M _ _ _ _ 2 2 . C - -	475	200L
306	3.19	666	2.87	44865	3 . 2		
268	3.64	760	2.87	45546	3 . 6		
242	4.03	844	2.87	46127	4 . 0		
221	4.42	927	2.87	46617	4 . 5		
193	5.04	1053	2.87	47389	5 . 0		
176	5.54	1158	2.87	48169	5 . 6		
157	6.21	1301	2.87	49031	6 . 3		
142	6.88	1444	2.87	49812	7 . 1		
125	7.78	1625	2.87	50854	8 . 0		
113	8.62	1799	2.87	51558	9 . 0		
99	9.89	2071	2.87	52476	1 0 .		
87	11.2	2352	2.53	53404	1 1 .		
79	12.39	2585	2.46	53867	1 2 .		
69	14.03	2930	2.15	54500	1 4 .		
61	15.97	3340	1.86	55592	1 6 .		
54	18	3761	1.65	56250	1 8 .		
49	20	4168	1.52	57575	2 0 .		
43	22.55	4694	1.35	58625	2 2 .		
38	25.45	5287	1.17	58564	2 5 .		
34	28.35	5890	1.05	59228	2 8 .		
31	31.89	6613	0.96	59030	3 2 .		
27	35.52	7355	0.86	60706	3 6 .		
25	39.01	8042	0.8	58551	4 0 .		
64	15.13	3159	3.29	74100	M 1 4 2 1 1 4 . _ M _ _ _ _ 2 2 . C - -	586	200L
59	16.43	3425	3.24	75400	1 6 .		
54	18.11	3774	2.94	77252	1 8 .		
45	21.75	4528	2.34	79634	2 0 .		
41	23.97	4998	2.16	78485	2 2 .		
37	26.07	5441	1.95	78835	2 5 .		
35	28.25	5874	1.7	77725	2 8 .		
28	34.51	7175	1.49	75975	3 2 .		
26	37.39	7746	1.39	75375	3 6 .		
25	39.42	8133	1.24	80706	4 0 .		
23	42.71	8821	1.14	80752	4 5 .		
24	41.36	8550	1.23	65304	M 1 4 3 1 4 0 . _ M _ _ _ _ 2 2 . C - -	631	200L
20	48.21	9887	1.11	65304	4 5 .		
18	54.75	11239	0.98	65304	5 0 .		
16	59.46	12205	0.91	80900	5 6 .		
15	65.55	13508	0.82	80900	6 3 .		

NOTE

Other output speeds are available using 2 and 8 pole motors - Consult Application Engineering

SERIES M

SELECTION TABLES

GEARED MOTORS

30.0 kW

4 POLE

N2 R/MIN	i	M2 Nm	Fm	N	Unit Designation	Kg	Motor Size
Output Speed	Ratio	Output Torque	Service Factor	Overhung Load	Column Entry [1] Through [20] Spaces to be filled when entering order	Weight	
994	1.48	281	2.64	13326	M 0 9 2 1 1 . 4 _ M _ _ _ _ 3 0 . A _ _	368	200L
722	2.04	387	2.56	14700	1 . 8		
644	2.28	434	2.48	15200	2 . 2		
574	2.56	486	2.22	15700	2 . 5		
495	2.97	562	2.49	16600	2 . 8		
445	3.3	632	1.72	16900	3 . 2		
399	3.69	705	1.54	17450	3 . 6		
360	4.09	774	2.06	17850	4 . 0		
321	4.58	872	1.93	18100	4 . 5		
290	5.07	964	1.81	18300	5 . 0		
259	5.69	1077	1.69	18450	5 . 6		
222	6.63	1259	1.52	18450	6 . 3		
199	7.4	1405	1.42	18136	7 . 1		
179	8.22	1558	1.33	18263	8 . 0		
160	9.19	1744	1.24	17790	9 . 0		
143	10.27	1955	1.15	14859	1 0 .		
126	11.71	2226	1.05	15300	1 1 .		
115	12.74	2419	1	15300	1 2 .		
101	14.53	2762	0.92	13400	1 4 .		
1019	1.44	273	2.64	17995	M 1 0 2 1 1 . 4 _ M _ _ _ _ 3 0 . A _ _	414	200L
730	2.01	382	2.64	19960	1 . 8		
671	2.19	416	2.64	20460	2 . 2		
591	2.49	473	2.64	21260	2 . 5		
491	2.99	563	2.64	22626	2 . 8		
453	3.24	615	2.49	23056	3 . 2		
420	3.5	666	2.34	23556	3 . 6		
352	4.18	790	2.64	25056	4 . 0		
323	4.55	862	2.64	25356	4 . 5		
298	4.94	934	2.64	25621	5 . 0		
274	5.37	1017	2.64	25886	5 . 6		
219	6.72	1274	2.46	26417	6 . 3		
202	7.26	1374	2.34	26649	7 . 1		
185	7.95	1504	2.21	27049	8 . 0		
171	8.58	1621	2.11	27400	9 . 0		
139	10.59	2009	1.83	28100	1 0 .		
123	11.98	2272	1.66	28550	1 1 .		
118	12.51	2368	1.64	28750	1 2 .		
104	14.16	2675	1.51	29227	1 4 .		
506	2.9	548	3.17	39200	M 1 3 2 1 2 . 8 _ M _ _ _ _ 3 0 . A _ _	475	200L
461	3.19	602	3.17	40200	3 . 2		
404	3.64	684	3.17	41800	3 . 6		
365	4.03	763	3.17	43000	4 . 0		
333	4.42	839	3.17	44100	4 . 5		
292	5.04	952	3.17	44800	5 . 0		
265	5.54	1047	3.17	45300	5 . 6		
237	6.21	1176	3.17	45800	6 . 3		
214	6.88	1302	3.17	46300	7 . 1		
189	7.78	1470	3.17	47100	8 . 0		
171	8.62	1627	3.17	47800	9 . 0		
149	9.89	1873	3.17	48800	1 0 .		
131	11.2	2125	2.79	49517	1 1 .		
119	12.39	2340	2.71	50288	1 2 .		
105	14.03	2647	2.38	50461	1 4 .		
92	15.97	3017	2.05	51237	1 6 .		
82	18	3403	1.82	51562	1 8 .		
73	20	3765	1.69	51975	2 0 .		
65	22.55	4241	1.5	52132	2 2 .		
58	25.45	4790	1.29	53590	2 5 .		
52	28.35	5333	1.16	55208	2 8 .		
46	31.89	5984	1.06	56057	3 2 .		
41	35.52	6639	0.96	58200	3 6 .		
38	39.01	7296	0.89	56700	4 0 .		
97	15.13	2849	3.65	68600	M 1 4 2 1 1 4 . _ M _ _ _ _ 3 0 . A _ _	586	200L
89	16.43	3096	3.21	69600	1 6 .		
81	18.11	3428	3	70600	1 8 .		
68	21.75	4089	2.59	71941	2 0 .		
61	23.97	4520	2.39	72513	2 2 .		
56	26.07	4870	2.16	73600	2 5 .		
52	28.25	5306	1.88	75987	2 8 .		
43	34.51	6488	1.65	75912	3 2 .		
39	37.39	7008	1.54	75650	3 6 .		
37	39.42	7372	1.35	80463	4 0 .		
34	42.71	7976	1.25	80900	4 5 .		
36	41.36	7685	1.27	65824	M 1 4 3 1 4 0 . _ M _ _ _ _ 3 0 . A _ _	631	200L
30	48.21	8942	1.23	65824	4 5 .		
27	54.75	10140	1.08	65824	5 0 .		
25	59.46	11057	0.95	65600	5 6 .		
22	65.55	12178	0.88	65600	6 3 .		

NOTE

Other output speeds are available using 2 and 8 pole motors - Consult Application Engineering

SERIES M

SELECTION TABLES

GEARED MOTORS

30.0 kW

6 POLE

N2 R/MIN	i	M2 Nm	Fm	N	Unit Designation	Kg	Motor Size
Output Speed	Ratio	Output Torque	Service Factor	Overhung Load	Column Entry [1] Through [20] Spaces to be filled when entering order	Weight	
663	1.48	422	1.76	15000	M 0 9 2 1 1 . 4 _ M _ _ _ _ 3 0 . C _ _	462	225M
481	2.04	584	1.76	16400	1 . 8		
429	2.28	656	1.66	16900	2 . 2		
383	2.56	736	1.48	17400	2 . 5		
330	2.97	845	1.76	17800	2 . 8		
297	3.3	947	1.15	17600	3 . 2		
266	3.69	1060	1.03	17700	3 . 6		
240	4.09	1163	1.56	18200	4 . 0		
214	4.58	1310	1.45	18400	4 . 5		
193	5.07	1447	1.37	18700	5 . 0		
172	5.69	1618	1.27	18900	5 . 6		
148	6.63	1886	1.15	17100	6 . 3		
132	7.4	2108	1.07	15900	7 . 1		
119	8.22	2343	1.01	15700	8 . 0		
107	9.19	2618	0.94	14100	9 . 0		
95	10.27	2927	0.86	10900	1 0 .		
679	1.44	409	1.76	20300	M 1 0 2 1 1 . 4 _ M _ _ _ _ 3 0 . C _ _	508	225M
486	2.01	573	1.76	22500	1 . 8		
447	2.19	624	1.76	23100	2 . 2		
394	2.49	709	1.76	24000	2 . 5		
328	2.99	850	1.76	25200	2 . 8		
302	3.24	926	1.69	25100	3 . 2		
280	3.5	1000	1.57	25300	3 . 6		
234	4.18	1185	1.76	26000	4 . 0		
216	4.55	1293	1.76	26200	4 . 5		
198	4.94	1401	1.76	26500	5 . 0		
182	5.37	1526	1.76	26800	5 . 6		
146	6.72	1911	1.76	27500	6 . 3		
135	7.26	2065	1.76	27700	7 . 1		
123	7.95	2255	1.67	28100	8 . 0		
114	8.58	2435	1.59	28300	9 . 0		
93	10.59	3010	1.25	28700	1 0 .		
82	11.98	3408	1.11	28900	1 1 .		
78	12.51	3552	1.24	29100	1 2 .		
69	14.16	4024	1.1	27500	1 4 .		
337	2.9	823	2.11	44090	M 1 3 2 1 2 . 8 _ M _ _ _ _ 3 0 . C _ _	569	225M
307	3.19	903	2.11	44558	3 . 2		
269	3.64	1031	2.11	45195	3 . 6		
243	4.03	1145	2.11	45732	4 . 0		
222	4.42	1258	2.11	46201	4 . 5		
194	5.04	1429	2.11	46906	5 . 0		
177	5.54	1571	2.11	47643	5 . 6		
158	6.21	1765	2.11	48417	6 . 3		
142	6.88	1959	2.11	49154	7 . 1		
126	7.78	2205	2.11	50065	8 . 0		
114	8.62	2441	2.11	50550	9 . 0		
99	9.89	2811	2.11	51052	1 0 .		
88	11.2	3191	1.86	51584	1 1 .		
79	12.39	3507	1.81	51887	1 2 .		
70	14.03	3975	1.58	52100	1 4 .		
61	15.97	4532	1.37	52612	1 6 .		
54	18	5103	1.21	52868	1 8 .		
49	20	5654	1.12	53775	2 0 .		
43	22.55	6369	1	54134	2 2 .		
39	25.45	7173	0.86	54020	2 5 .		
339	2.89	817	3.08	56900	M 1 4 2 1 2 . 8 _ M _ _ _ _ 3 0 . C _ _	681	225M
302	3.25	921	3.08	58400	3 . 2		
256	3.82	1080	3.08	59600	3 . 6		
243	4.03	1145	3.08	60000	4 . 0		
216	4.54	1287	3.08	60800	4 . 5		
184	5.33	1511	3.08	62000	5 . 0		
163	6	1699	3.08	63200	5 . 6		
150	6.55	1858	3.08	64200	6 . 3		
135	7.27	2062	3.08	65300	7 . 1		
113	8.67	2455	3.08	67100	8 . 0		
102	9.62	2724	3.08	68200	9 . 0		
97	10.06	2857	3.08	68700	1 0 .		
86	11.43	3240	3.08	70100	1 1 .		
74	13.32	3756	2.72	71600	1 2 .		
65	15.13	4286	2.43	72621	1 4 .		
60	16.43	4646	2.39	74066	1 6 .		
54	18.11	5120	2.17	75542	1 8 .		
45	21.75	6144	1.73	76741	2 0 .		
41	23.97	6781	1.59	75725	2 2 .		
38	26.07	7381	1.44	76475	2 5 .		
35	28.25	7969	1.25	75415	2 8 .		
28	34.51	9735	1.1	72393	3 2 .		
26	37.39	10509	1.03	71356	3 6 .		
25	39.42	11034	0.92	80600	4 0 .		
23	42.71	11968	0.84	80671	4 5 .		
24	41.36	11600	0.91	64700	M 1 4 3 1 4 0 . _ M _ _ _ _ 3 0 . C _ _	726	225M
20	48.21	13413	0.82	64700	4 5 .		

NOTE
Other output speeds are available using 2 and 8 pole motors - Consult Application Engineering

SERIES M

SELECTION TABLES

GEARED MOTORS

37.0 kW

4 POLE

N2 R/MIN	i	M2 Nm	Fm	N	Unit Designation	Kg	Motor Size
Output Speed	Ratio	Output Torque	Service Factor	Overhung Load	Column Entry [1] Through [20] Spaces to be filled when entering order	Weight	
997	1.48	345	2.15	13220	M 0 9 2 1 1 . 4 _ M _ _ _ _ 3 7 . A _ _	427	225S
724	2.04	476	2.09	14560	1 . 8		
646	2.28	534	2.02	15013	2 . 2		
576	2.56	597	1.81	15513	2 . 5		
497	2.97	690	2.03	16413	2 . 8		
447	3.3	777	1.4	16666	3 . 2		
400	3.69	867	1.26	17193	3 . 6		
361	4.09	952	1.68	17593	4 . 0		
322	4.58	1072	1.57	17820	4 . 5		
291	5.07	1185	1.48	18020	5 . 0		
259	5.69	1323	1.37	18100	5 . 6		
223	6.63	1548	1.24	17960	6 . 3		
199	7.4	1727	1.16	17372	7 . 1		
179	8.22	1915	1.09	17393	8 . 0		
161	9.19	2144	1.01	16581	9 . 0		
144	10.27	2403	0.93	12700	1 0 .		
1023	1.44	335	2.15	17904	M 1 0 2 1 1 . 4 _ M _ _ _ _ 3 7 . A _ _	473	225S
732	2.01	469	2.15	19839	1 . 8		
673	2.19	511	2.15	20339	2 . 2		
593	2.49	581	2.15	21139	2 . 5		
493	2.99	693	2.15	22473	2 . 8		
455	3.24	756	2.02	22843	3 . 2		
421	3.5	818	1.91	23343	3 . 6		
353	4.18	972	2.15	24843	4 . 0		
325	4.55	1060	2.15	25143	4 . 5		
299	4.94	1148	2.15	25378	5 . 0		
275	5.37	1251	2.15	25613	5 . 6		
219	6.72	1566	2	26082	6 . 3		
203	7.26	1690	1.91	26252	7 . 1		
186	7.95	1849	1.8	26652	8 . 0		
172	8.58	1993	1.72	26933	9 . 0		
139	10.59	2469	1.49	27493	1 0 .		
123	11.98	2792	1.35	27873	1 1 .		
118	12.51	2911	1.34	28073	1 2 .		
104	14.16	3288	1.23	28421	1 4 .		
508	2.9	674	2.58	39071	M 1 3 2 1 2 . 8 _ M _ _ _ _ 3 7 . A _ _	534	225S
463	3.19	740	2.58	40071	3 . 2		
405	3.64	841	2.58	41648	3 . 6		
366	4.03	938	2.58	42825	4 . 0		
334	4.42	1031	2.58	43913	4 . 5		
293	5.04	1171	2.58	44590	5 . 0		
266	5.54	1287	2.58	45066	5 . 6		
238	6.21	1446	2.58	45543	6 . 3		
214	6.88	1601	2.58	46020	7 . 1		
190	7.78	1807	2.58	46773	8 . 0		
171	8.62	2000	2.58	47368	9 . 0		
149	9.89	2303	2.58	48181	1 0 .		
132	11.2	2612	2.27	48745	1 1 .		
119	12.39	2876	2.21	49402	1 2 .		
105	14.03	3254	1.93	49098	1 4 .		
92	15.97	3709	1.67	49855	1 6 .		
82	18	4183	1.48	49865	1 8 .		
74	20	4628	1.37	50050	2 0 .		
65	22.55	5213	1.22	49967	2 2 .		
58	25.45	5888	1.05	51215	2 5 .		
52	28.35	6555	0.95	52800	2 8 .		
46	31.89	7355	0.86	53400	3 2 .		
511	2.89	669	3.77	50300	M 1 4 2 1 2 . 8 _ M _ _ _ _ 3 7 . A _ _	646	225S
454	3.25	754	3.77	52100	3 . 2		
386	3.82	884	3.77	54600	3 . 6		
366	4.03	937	3.77	55400	4 . 0		
325	4.54	1054	3.77	57400	4 . 5		
277	5.33	1237	3.77	58800	5 . 0		
246	6	1391	3.77	59600	5 . 6		
225	6.55	1521	3.77	60200	6 . 3		
203	7.27	1688	3.77	60900	7 . 1		
170	8.67	2009	3.77	62400	8 . 0		
153	9.62	2230	3.77	63400	9 . 0		
147	10.06	2336	3.77	63900	1 0 .		
129	11.43	2662	3.44	65200	1 1 .		
111	13.32	3066	3.33	66700	1 2 .		
98	15.13	3502	2.97	67981	1 4 .		
90	16.43	3805	2.61	68981	1 6 .		
81	18.11	4214	2.44	69783	1 8 .		
68	21.75	5026	2.11	70489	2 0 .		
62	23.97	5556	1.94	70879	2 2 .		
57	26.07	5986	1.75	71531	2 5 .		
52	28.25	6522	1.53	74395	2 8 .		
43	34.51	7975	1.34	73585	3 2 .		
39	37.39	8614	1.25	73200	3 6 .		
37	39.42	9061	1.1	80293	4 0 .		
35	42.71	9804	1.02	80900	4 5 .		
36	41.36	9447	1.03	65600	M 1 4 3 1 4 0 . _ M _ _ _ _ 3 7 . A _ _	691	225S
31	48.21	10991	1	65600	4 5 .		
27	54.75	12464	0.88	65600	5 0 .		

NOTE

Other output speeds are available using 2 and 8 pole motors - Consult Application Engineering

SERIES M

SELECTION TABLES

GEARED MOTORS

37.0 kW

6 POLE

N2 R/MIN	i	M2 Nm	Fm	N	Unit Designation	Kg	Motor Size
Output Speed	Ratio	Output Torque	Service Factor	Overhung Load	Column Entry [1] Through [20] Spaces to be filled when entering order	Weight	
337	2.9	1015	1.71	43841	M 1 3 2 1 2 . 8 _ M _ _ _ _ 3 7 . C _ _	646	250M
307	3.19	1114	1.71	44290			
269	3.64	1272	1.71	44889			
243	4.03	1412	1.71	45387			
222	4.42	1552	1.71	45836			
194	5.04	1762	1.71	46484			
177	5.54	1937	1.71	47183			
158	6.21	2177	1.71	47880			
142	6.88	2416	1.71	48579			
126	7.78	2719	1.71	49375			
114	8.62	3011	1.71	49668			
99	9.89	3466	1.71	49805			
88	11.2	3935	1.51	49993			
79	12.39	4326	1.47	50155			
70	14.03	4902	1.28	50000			
61	15.97	5590	1.11	50005			
54	18	6294	0.98	49909			
49	20	6974	0.91	50450			
43	22.55	7855	0.81	50204			
339	2.89	1008	2.5	56704	M 1 4 2 1 2 . 8 _ M _ _ _ _ 3 7 . C _ _	761	250M
302	3.25	1136	2.5	58176			
256	3.82	1332	2.5	59320			
243	4.03	1412	2.5	59720			
216	4.54	1588	2.5	60492			
184	5.33	1864	2.5	61608			
163	6	2096	2.5	62780			
150	6.55	2292	2.5	63724			
135	7.27	2544	2.5	64768			
113	8.67	3028	2.5	66456			
102	9.62	3360	2.5	67500			
97	10.06	3524	2.5	68000			
86	11.43	3996	2.5	69288			
74	13.32	4632	2.2	70620			
65	15.13	5286	1.97	71327			
60	16.43	5731	1.94	72900			
54	18.11	6315	1.76	74046			
45	21.75	7577	1.4	74209			
41	23.97	8364	1.29	73310			
38	26.07	9104	1.16	74410			
35	28.25	9829	1.02	73395			
28	34.51	12006	0.89	69259			
26	37.39	12961	0.83	67840			

NOTE

Other output speeds are available using 2 and 8 pole motors - Consult Application Engineering

SERIES M

SELECTION TABLES

GEARED MOTORS

45.0 kW

4 POLE

N2 R/MIN	i	M2 Nm	Fm	N	Unit Designation	Kg	Motor Size
Output Speed	Ratio	Output Torque	Service Factor	Overhung Load	Column Entry [1] Through [20] Spaces to be filled when entering order	Weight	
997	1.48	420	1.77	13100	M 0 9 2 1 1 . 4 _ M _ _ _ _ 4 5 . A _ _	462	225M
724	2.04	579	1.72	14400	1 . 8		
646	2.28	650	1.66	14800	2 . 2		
576	2.56	727	1.49	15300	2 . 5		
497	2.97	840	1.67	16200	2 . 8		
447	3.3	945	1.15	16400	3 . 2		
400	3.69	1055	1.03	16900	3 . 6		
361	4.09	1158	1.38	17300	4 . 0		
322	4.58	1303	1.29	17500	4 . 5		
291	5.07	1441	1.21	17700	5 . 0		
259	5.69	1610	1.13	17700	5 . 6		
223	6.63	1883	1.02	17400	6 . 3		
199	7.4	2101	0.95	16500	7 . 1		
179	8.22	2329	0.89	16400	8 . 0		
161	9.19	2608	0.83	15200	9 . 0		
1023	1.44	408	1.77	17800	M 1 0 2 1 1 . 4 _ M _ _ _ _ 4 5 . A _ _	508	225M
732	2.01	571	1.77	19700	1 . 8		
673	2.19	622	1.77	20200	2 . 2		
593	2.49	707	1.77	21000	2 . 5		
493	2.99	842	1.77	22300	2 . 8		
455	3.24	919	1.66	22600	3 . 2		
421	3.5	995	1.57	23100	3 . 6		
353	4.18	1182	1.77	24600	4 . 0		
325	4.55	1289	1.77	24900	4 . 5		
299	4.94	1397	1.77	25100	5 . 0		
275	5.37	1521	1.77	25300	5 . 6		
219	6.72	1905	1.65	25700	6 . 3		
203	7.26	2055	1.57	25800	7 . 1		
186	7.95	2249	1.48	26200	8 . 0		
172	8.58	2424	1.41	26400	9 . 0		
139	10.59	3003	1.23	26800	1 0 .		
123	11.98	3396	1.11	27100	1 1 .		
118	12.51	3540	1.1	27300	1 2 .		
104	14.16	3999	1.01	27500	1 4 .		
90	16.43	4645	0.81	24900	1 6 .		
508	2.9	820	2.12	38925	M 1 3 2 1 2 . 8 _ M _ _ _ _ 4 5 . A _ _	569	225M
463	3.19	900	2.12	39925	3 . 2		
405	3.64	1023	2.12	41475	3 . 6		
366	4.03	1141	2.12	42625	4 . 0		
334	4.42	1254	2.12	43700	4 . 5		
293	5.04	1424	2.12	44350	5 . 0		
266	5.54	1565	2.12	44800	5 . 6		
238	6.21	1759	2.12	45250	6 . 3		
214	6.88	1947	2.12	45700	7 . 1		
190	7.78	2197	2.12	46400	8 . 0		
171	8.62	2433	2.12	46875	9 . 0		
149	9.89	2801	2.12	47475	1 0 .		
132	11.2	3177	1.87	47863	1 1 .		
119	12.39	3498	1.82	48391	1 2 .		
105	14.03	3958	1.59	47540	1 4 .		
92	15.97	4511	1.37	48275	1 6 .		
82	18	5088	1.22	47925	1 8 .		
74	20	5629	1.13	47850	2 0 .		
65	22.55	6341	1	47493	2 2 .		
58	25.45	7161	0.87	48500	2 5 .		
511	2.89	813	3.1	50194	M 1 4 2 1 2 . 8 _ M _ _ _ _ 4 5 . A _ _	681	225M
454	3.25	917	3.1	51979	3 . 2		
386	3.82	1075	3.1	54449	3 . 6		
366	4.03	1139	3.1	55249	4 . 0		
325	4.54	1281	3.1	57218	4 . 5		
277	5.33	1504	3.1	58588	5 . 0		
246	6	1691	3.1	59358	5 . 6		
225	6.55	1850	3.1	59943	6 . 3		
203	7.27	2053	3.1	60628	7 . 1		
170	8.67	2444	3.1	62052	8 . 0		
153	9.62	2712	3.1	63022	9 . 0		
147	10.06	2841	3.1	63507	1 0 .		
129	11.43	3238	2.83	64762	1 1 .		
111	13.32	3729	2.74	66171	1 2 .		
98	15.13	4259	2.44	67275	1 4 .		
90	16.43	4628	2.15	68275	1 6 .		
81	18.11	5125	2.01	68850	1 8 .		
68	21.75	6113	1.73	68830	2 0 .		
62	23.97	6757	1.6	69010	2 2 .		
57	26.07	7280	1.44	69167	2 5 .		
52	28.25	7932	1.26	72575	2 8 .		
43	34.51	9699	1.1	70925	3 2 .		
39	37.39	10477	1.03	70400	3 6 .		
37	39.42	11020	0.9	80100	4 0 .		

NOTE

Other output speeds are available using 2 and 8 pole motors - Consult Application Engineering

SERIES M

SELECTION TABLES

GEARED MOTORS

45.0 kW

6 POLE

N2 R/MIN	i	M2 Nm	Fm	N	Unit Designation	Kg	Motor Size
Output Speed	Ratio	Output Torque	Service Factor	Overhung Load	Column Entry <input type="text" value="1"/> Through <input type="text" value="20"/> Spaces to be filled when entering order	Weight	
337	2.9	1235	1.41	43556	M 1 3 2 1 2 . 8 _ M _ _ _ _ 4 5 . C _ _	771	280S
307	3.19	1355	1.41	43983			
269	3.64	1547	1.41	44538			
243	4.03	1717	1.41	44993			
222	4.42	1888	1.41	45420			
194	5.04	2143	1.41	46002			
177	5.54	2356	1.41	46657			
158	6.21	2647	1.41	47267			
142	6.88	2938	1.41	47921			
126	7.78	3307	1.41	48586			
114	8.62	3662	1.41	48660			
99	9.89	4216	1.41	48380			
88	11.2	4786	1.24	48173			
79	12.39	5261	1.21	48175			
70	14.03	5962	1.05	47600			
61	15.97	6798	0.91	47025			
54	18	7655	0.81	46527			
339	2.89	1226	2.06	56480	M 1 4 2 1 2 . 8 _ M _ _ _ _ 4 5 . C _ _	886	280S
302	3.25	1381	2.06	57920			
256	3.82	1620	2.06	59000			
243	4.03	1717	2.06	59400			
216	4.54	1931	2.06	60140			
184	5.33	2267	2.06	61160			
163	6	2549	2.06	62300			
150	6.55	2787	2.06	63180			
135	7.27	3094	2.06	64160			
113	8.67	3683	2.06	65720			
102	9.62	4087	2.06	66700			
97	10.06	4286	2.06	67200			
86	11.43	4860	2.06	68360			
74	13.32	5634	1.81	69500			
65	15.13	6429	1.62	69848			
60	16.43	6970	1.59	71566			
54	18.11	7681	1.45	72336			
45	21.75	9216	1.15	71316			
41	23.97	10172	1.06	70550			
38	26.07	11072	0.96	72050			
35	28.25	11954	0.83	71086			

NOTE
Other output speeds are available using 2 and 8 pole motors - Consult Application Engineering

SERIES M

SELECTION TABLES

GEARED MOTORS

55.0 kW

4 POLE

N2 R/MIN	i	M2 Nm	Fm	N	Unit Designation	Kg	Motor Size
Output Speed	Ratio	Output Torque	Service Factor	Overhung Load	Column Entry [1] Through [20] Spaces to be filled when entering order	Weight	
508	2.9	1002	1.73	38741	M 1 3 2 1 2 . 8 _ M _ _ _ _ 5 5 . A _ _	646	250M
463	3.19	1100	1.73	39741			
405	3.64	1250	1.73	41258			
366	4.03	1394	1.73	42375			
334	4.42	1533	1.73	43433			
293	5.04	1740	1.73	44050			
266	5.54	1913	1.73	44466			
238	6.21	2150	1.73	44883			
214	6.88	2380	1.73	45300			
190	7.78	2686	1.73	45933			
171	8.62	2974	1.73	46258			
149	9.89	3423	1.73	46591			
132	11.2	3883	1.53	46760			
119	12.39	4275	1.49	47126			
105	14.03	4837	1.3	45593			
92	15.97	5513	1.12	46300			
82	18	6219	1	45500			
74	20	6880	0.92	45100			
65	22.55	7750	0.82	44400			
511	2.89	994	2.53	50062	M 1 4 2 1 2 . 8 _ M _ _ _ _ 5 5 . A _ _	761	250M
454	3.25	1120	2.53	51828			
386	3.82	1314	2.53	54260			
366	4.03	1393	2.53	55060			
325	4.54	1566	2.53	56992			
277	5.33	1839	2.53	58324			
246	6	2067	2.53	59056			
225	6.55	2261	2.53	59622			
203	7.27	2510	2.53	60288			
170	8.67	2987	2.53	61618			
153	9.62	3315	2.53	62550			
147	10.06	3472	2.53	63016			
129	11.43	3957	2.31	64215			
111	13.32	4557	2.24	65511			
98	15.13	5206	2	66391			
90	16.43	5657	1.76	67391			
81	18.11	6264	1.64	67683			
68	21.75	7472	1.42	66757			
62	23.97	8259	1.31	66674			
57	26.07	8898	1.18	66211			
52	28.25	9695	1.03	70300			
43	34.51	11855	0.9	67600			
39	37.39	12805	0.84	66900			

55.0 kW

6 POLE

337	2.9	1509	1.15	43200	M 1 3 2 1 2 . 8 _ M _ _ _ _ 5 5 . C _ _	861	280M
307	3.19	1657	1.15	43600			
269	3.64	1891	1.15	44100			
243	4.03	2099	1.15	44500			
222	4.42	2307	1.15	44900			
194	5.04	2620	1.15	45400			
177	5.54	2880	1.15	46000			
158	6.21	3236	1.15	46500			
142	6.88	3591	1.15	47100			
126	7.78	4042	1.15	47600			
114	8.62	4476	1.15	47400			
99	9.89	5153	1.15	46600			
88	11.2	5850	1.02	45900			
79	12.39	6430	0.99	45700			
70	14.03	7287	0.86	44600			
339	2.89	1498	1.68	56200	M 1 4 2 1 2 . 8 _ M _ _ _ _ 5 5 . C _ _	976	280M
302	3.25	1688	1.68	57600			
256	3.82	1980	1.68	58600			
243	4.03	2099	1.68	59000			
216	4.54	2360	1.68	59700			
184	5.33	2771	1.68	60600			
163	6	3116	1.68	61700			
150	6.55	3407	1.68	62500			
135	7.27	3782	1.68	63400			
113	8.67	4501	1.68	64800			
102	9.62	4995	1.68	65700			
97	10.06	5239	1.68	66200			
86	11.43	5940	1.68	67200			
74	13.32	6886	1.48	68100			
65	15.13	7858	1.32	68000			
60	16.43	8519	1.3	69900			
54	18.11	9388	1.18	70200			
45	21.75	11264	0.94	67700			
41	23.97	12433	0.87	67100			

NOTE

Other output speeds are available using 2 and 8 pole motors - Consult Application Engineering

SERIES M

SELECTION TABLES

GEARED MOTORS

75.0 kW

4 POLE

N2 R/MIN	i	M2 Nm	Fm	N	Unit Designation	Kg	
Output Speed	Ratio	Output Torque	Service Factor	Overhung Load	Column Entry [1] Through [20] Spaces to be filled when entering order	Weight	Motor Size
511	2.9	1358	1.28	38375	M 1 3 2 1 2 . 8 _ M _ _ _ _ 7 5 . A - -	771	280S
466	3.19	1491	1.28	39375			
408	3.64	1694	1.28	40825			
369	4.03	1889	1.28	41875			
336	4.42	2076	1.28	42900			
295	5.04	2357	1.28	43450			
268	5.54	2592	1.28	43800			
239	6.21	2912	1.28	44150			
216	6.88	3224	1.28	44500			
191	7.78	3638	1.28	45000			
172	8.62	4028	1.28	45025			
150	9.89	4637	1.28	44825			
133	11.2	5259	1.13	44554			
120	12.39	5791	1.1	44597			
106	14.03	6552	0.96	41700			
514	2.89	1347	1.87	49798	M 1 4 2 1 2 . 8 _ M _ _ _ _ 7 5 . A - -	886	280S
457	3.25	1518	1.87	51526			
389	3.82	1780	1.87	53883			
369	4.03	1886	1.87	54683			
327	4.54	2122	1.87	56539			
278	5.33	2490	1.87	57796			
247	6	2801	1.87	58452			
227	6.55	3062	1.87	58981			
204	7.27	3399	1.87	59609			
171	8.67	4046	1.87	60750			
154	9.62	4490	1.87	61607			
148	10.06	4703	1.87	62035			
130	11.43	5360	1.71	63120			
111	13.32	6173	1.65	64190			
98	15.13	7052	1.47	64625			
90	16.43	7662	1.3	65625			
82	18.11	8484	1.21	65350			
68	21.75	10120	1.05	62610			
62	23.97	11186	0.97	62003			
57	26.07	12052	0.87	60300			

90.0 kW

4 POLE

N2 R/MIN	i	M2 Nm	Fm	N	Unit Designation	Kg	
Output Speed	Ratio	Output Torque	Service Factor	Overhung Load	Column Entry [1] Through [20] Spaces to be filled when entering order	Weight	Motor Size
511	2.9	1630	1.07	38100	M 1 3 2 1 2 . 8 _ M _ _ _ _ 9 0 . A - -	861	280M
466	3.19	1789	1.07	39100			
408	3.64	2033	1.07	40500			
369	4.03	2267	1.07	41500			
336	4.42	2492	1.07	42500			
295	5.04	2829	1.07	43000			
268	5.54	3110	1.07	43300			
239	6.21	3494	1.07	43600			
216	6.88	3869	1.07	43900			
191	7.78	4365	1.07	44300			
172	8.62	4834	1.07	44100			
150	9.89	5565	1.07	43500			
133	11.2	6311	0.94	42900			
120	12.39	6949	0.91	42700			
514	2.89	1616	1.56	49600	M 1 4 2 1 2 . 8 _ M _ _ _ _ 9 0 . A - -	976	280M
457	3.25	1821	1.56	51300			
389	3.82	2136	1.56	53600			
369	4.03	2264	1.56	54400			
327	4.54	2546	1.56	56200			
278	5.33	2989	1.56	57400			
247	6	3361	1.56	58000			
227	6.55	3675	1.56	58500			
204	7.27	4079	1.56	59100			
171	8.67	4855	1.56	60100			
154	9.62	5388	1.56	60900			
148	10.06	5644	1.56	61300			
130	11.43	6432	1.42	62300			
111	13.32	7407	1.38	63200			
98	15.13	8462	1.23	63300			
90	16.43	9195	1.08	64300			
82	18.11	10181	1.01	63600			
68	21.75	12144	0.87	59500			
62	23.97	13424	0.8	58500			

NOTE

Other output speeds are available using 2 and 8 pole motors - Consult Application Engineering

SERIES M

DIMENSIONS - DOUBLE REDUCTION BASE MOUNT

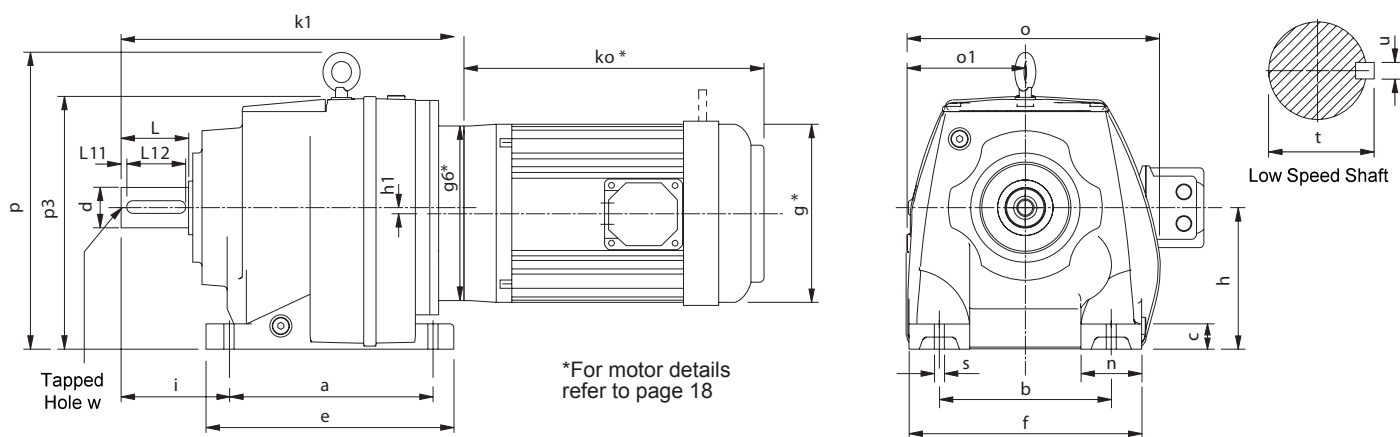

Size	a	b	c	e	f	h	h1	i	n	o	o1	p	p3	s	Low Speed Shaft						
															d	L	L11	L12	t	u	w
M0122	110	110	12	131	135	75	-	58	25	152	76	-	149	10	20 k6	40	4	32	22.5	6	M6 x 1 16 deep
M0222	130	110	16	152	145	90	-	75	35	170	84	-	180	10	25 k6	50	4	40	28	8	M10 x 1.5 22 deep
M0322	130	110	16	152	145	90	-	75	35	170	84	-	180	10	25 k6	50	4	40	28	8	M10 x 1.5 22 deep
M0422	165	135	20	200	190	115	-	90	55	204	97	-	208	15	30 k6	60	4	50	33	8	M10 x 1.5 22 deep
M0522	165	135	20	200	190	115	-	100	55	204	97	-	208	15	35 k6	70	7	60	38	10	M12 x 1.75 28 deep
M0622	195	150	24	235	210	130	14.5	100	60	220	110	246	214	15	35 k6	70	7	60	38	10	M12 x 1.75 28 deep
M0722	205	170	25	245	230	140	-	115	60	252	119	295	250	19	40 k6	80	5	70	43	12	M16 x 2.0 36 deep
M0822	260	215	35	310	290	180	-	140	75	320	167	360	310	19	50 k6	100	10	80	53.5	14	M16 x 2.0 36 deep
M0921	310	250	40	365	340	225	-	160	90	372	200	433	394	23	60 m6	120	10	100	64	18	M20 x 2.5 42 deep
M1021	370	290	45	440	400	250	-	185	110	428	225	505	446	27	70 m6	140	15	110	74.5	20	M20 x 2.5 42 deep
M1321	410	340	50	490	450	265	-	220	110	470	242	563	483	34	90 m6	170	15	140	95	25	M24 x 3.0 50 deep
M1421	500	380	50	590	530	300	-	260	150	546	278	630	551	41	100 m6	210	15	180	106	28	M24 x 3.0 50 deep

MOTOR FRAME SIZE	M0122	M0222	M0322	M0422	M0522	M0622	M0722	M0822	M0921	M1021	M1321	M1421
	K1	K1	K1	K1	K1	K1	K1	K1	K1	K1	K1	K1
63	209	240	240	270	280	301	-	-	-	-	-	-
71	213	244	244	276	286	307	-	-	-	-	-	-
80	226	257	257	294	304	325	362	477	523	-	-	-
90	236	267	267	304	314	335	372	477	523	-	-	-
100	244	275	275	331	341	362	384	483	529	596	717	832
112	244	275	275	331	341	362	384	483	529	596	717	832
132	-	-	-	331	733	362	406	483	564	596	717	832
160	-	-	-	-	-	-	414	513	564	631	710	825
180	-	-	-	-	-	-	-	-	564	564	710	825
200	-	-	-	-	-	-	-	-	564	564	710	825
225	-	-	-	-	-	-	-	-	591	591	737	852
250	-	-	-	-	-	-	-	-	-	-	909	1024
280	-	-	-	-	-	-	-	-	-	-	909	1024

kb - for brake motors
g2 - hand release if required

all parallel keys are to DIN 6885

SERIES M

DIMENSIONS - TRIPLE REDUCTION BASE MOUNT

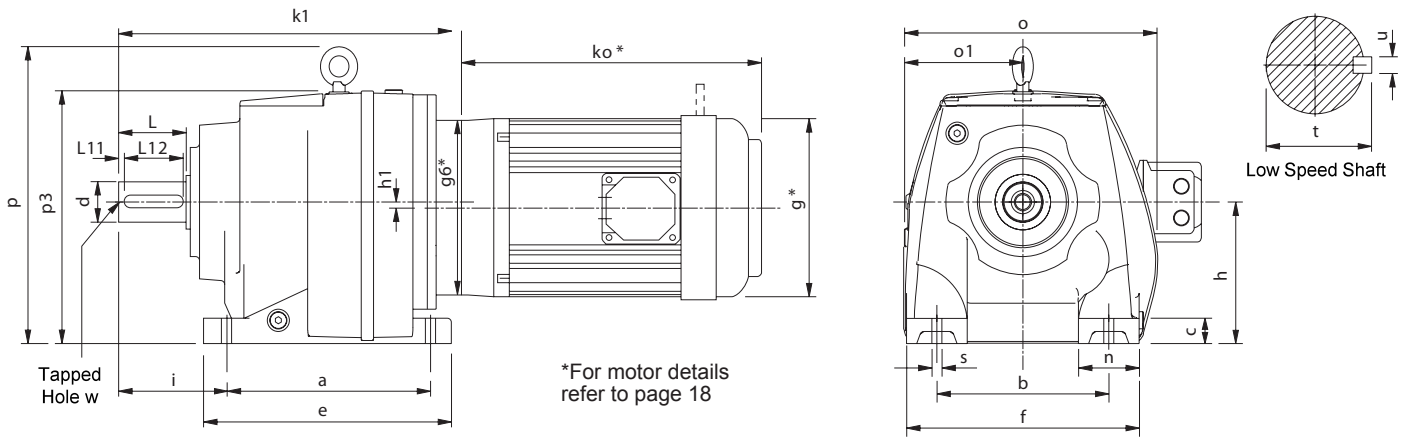

Size	a	b	c	e	f	h	h1	i	n	o	o1	p	p3	s	Low Speed Shaft						
															d	L	L11	L12	t	u	w
M0132	110	110	12	131	135	75	-	58	25	152	76	-	149	10	20 k6	40	4	32	22.5	6	M6 x 1 16 deep
M0232	130	110	16	152	145	90	-	75	35	170	84	-	180	10	25 k6	50	4	40	28	8	M10 x 1.5 22 deep
M0332	130	110	16	152	145	90	-	75	35	170	84	-	180	10	25 k6	50	4	40	28	8	M10 x 1.5 22 deep
M0432	165	135	20	200	190	115	-	90	55	204	97	-	208	15	30 k6	60	4	50	33	8	M10 x 1.5 22 deep
M0532	165	135	20	200	190	115	-	100	55	204	97	-	208	15	35 k6	70	7	60	38	10	M12 x 1.75 28 deep
M0632	195	150	24	235	210	130	14.5	100	60	220	110	246	214	15	35 k6	70	7	60	38	10	M12 x 1.75 28 deep
M0732	205	170	25	245	230	140	-	115	60	252	119	295	250	19	40 k6	80	5	70	43	12	M16 x 2.0 36 deep
M0832	260	215	35	310	290	180	-	140	75	320	167	360	310	19	50 k6	100	10	80	53.5	14	M16 x 2.0 36 deep
M0931	310	250	40	365	340	225	-	160	90	372	200	433	394	23	60 m6	120	10	100	64	18	M20 x 2.5 42 deep
M1031	370	290	45	440	400	250	-	185	110	428	225	505	446	27	70 m6	140	15	110	74.5	20	M20 x 2.5 42 deep
M1331	410	340	50	490	450	265	-	220	110	470	242	563	483	34	90 m6	170	15	140	95	25	M24 x 3.0 50 deep
M1431	500	380	50	590	530	300	-	260	150	546	278	630	551	41	100 m6	210	15	180	106	28	M24 x 3.0 50 deep

MOTOR FRAME SIZE	M0132	M0232	M0332	M0432	M0532	M0632	M0732	M0832	M0931	M1031	M1331	M1431
	K1	K1	K1	K1	K1	K1	K1	K1	K1	K1	K1	K1
63	224	253	253	300	310	331	353	-	-	-	-	-
71	228	257	257	304	314	335	359	-	-	-	-	-
80	241	270	270	317	327	348	377	462	549	647	-	-
90	251	280	280	327	337	358	387	472	549	647	-	-
100	259	288	288	335	345	366	414	484	555	653	779	904
112	259	288	288	335	345	366	414	484	555	653	779	904
132	-	-	-	-	-	-	414	506	-	653	779	904
160	-	-	-	-	-	-	-	-	-	688	772	897
180	-	-	-	-	-	-	-	-	-	688	772	897
200	-	-	-	-	-	-	-	-	-	688	772	897
225	-	-	-	-	-	-	-	-	-	715	799	924
250	-	-	-	-	-	-	-	-	-	-	971	1096
280	-	-	-	-	-	-	-	-	-	-	971	1096

kb - for brake motors
g2 - hand release if required

all parallel keys are to DIN 6885

SERIES M

DIMENSIONS - QUADRUPLE REDUCTION BASE MOUNT

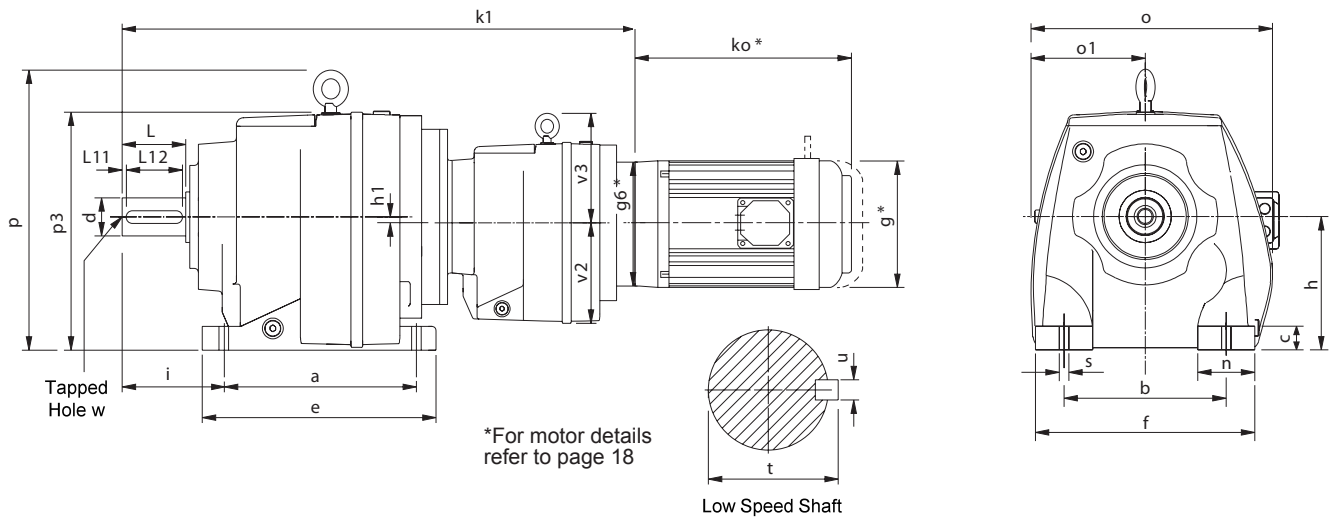

Size	a	b	c	e	f	h	h1	i	n	o	o1	p	p3	s	v2	v3	Low Speed Shaft						
																	d	L	L11	L12	t	u	w
M0342	130	110	16	152	145	90	-	75	35	170	84	-	180	10	76	-	25	50	4	40	28	8	M10 x 1.5 22 deep
M0442	165	135	20	200	190	115	-	90	55	204	97	-	208	15	91	-	30	60	4	50	33	8	M10 x 1.5 22 deep
M0542	165	135	20	200	190	115	-	100	55	204	97	-	208	15	91	-	35	70	7	60	38	10	M12 x 1.75 28 deep
M0642	195	150	24	235	210	130	14.5	100	60	220	110	246	214	15	91	-	35	70	7	60	38	10	M12 x 1.75 28 deep
M0742	205	170	25	245	230	140	-	115	60	252	119	295	250	19	91	-	40	80	5	70	43	12	M16 x 2.0 36 deep
M0842	260	215	35	310	290	180	-	140	75	320	167	360	310	19	115	-	50	100	10	80	53.5	14	M16 x 2.0 36 deep
M0941	310	250	40	365	340	225	-	160	90	372	200	433	394	23	115	-	60	120	10	100	64	18	M20 x 2.5 42 deep
M1041	370	290	45	440	400	250	-	185	110	428	225	505	446	27	140	155	70	140	15	110	74.5	20	M20 x 2.5 42 deep
M1341	410	340	50	490	450	265	-	220	110	470	242	563	483	34	140	155	90	170	15	140	95	25	M24 x 3.0 50 deep
M1441	500	380	50	590	530	300	-	260	150	546	278	630	551	41	140	155	100	210	15	180	106	28	M24 x 3.0 50 deep

MOTOR FRAME SIZE	M0342	M0442	M0542	M0642	M0742	M0842	M0941	M1041	M1341	M1441
	K1	K1	K1	K1	K1	K1	K1	K1	K1	K1
63	426	494	504	525	562	652	733	-	-	-
71	430	498	508	529	566	658	739	-	-	-
80	443	511	521	542	579	676	757	878	999	1114
90	453	521	531	552	589	686	767	888	1009	1124
100	-	-	-	-	-	713	794	900	1021	1136
112	-	-	-	-	-	713	794	900	1021	1136
132	-	-	-	-	-	713	794	922	1043	1158
160	-	-	-	-	-	-	-	930	1051	1166

kb - for brake motors
g2 - hand release if required

all parallel keys are to DIN 6885

SERIES M

DIMENSIONS - QUINTUPLE REDUCTION BASE MOUNT

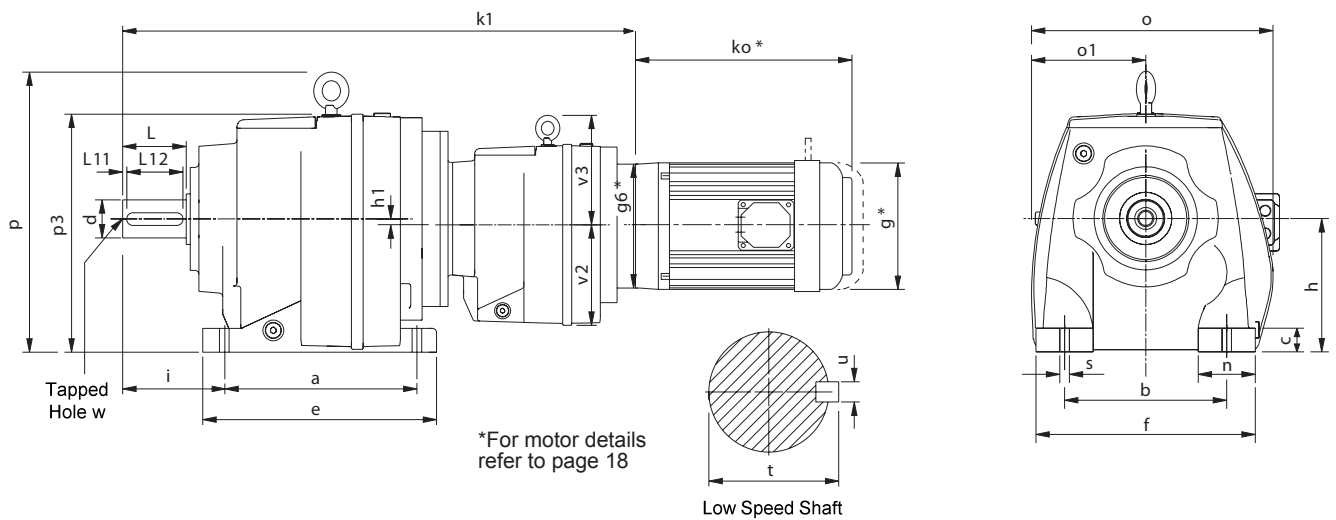

Size	a	b	c	e	f	h	h1	i	n	o	o1	p	p3	s	v2	v3	Low Speed Shaft						
																	d	L	L11	L12	t	u	w
M0352	130	110	16	152	145	90	-	75	35	170	84	-	180	10	76	-	25	50	4	40	28	8	M10 x 1.5 22 deep
M0452	165	135	20	200	190	115	-	90	55	204	97	-	208	15	91	-	30	60	4	50	33	8	M10 x 1.5 22 deep
M0552	165	135	20	200	190	115	-	100	55	204	97	-	208	15	91	-	35	70	7	60	38	10	M12 x 1.75 28 deep
M0652	195	150	24	235	210	130	14.5	100	60	220	110	246	214	15	91	-	35	70	7	60	38	10	M12 x 1.75 28 deep
M0752	205	170	25	245	230	140	-	115	60	252	119	295	250	19	91	-	40	80	5	70	43	12	M16 x 2.0 36 deep
M0852	260	215	35	310	290	180	-	140	75	320	167	360	310	19	115	-	50	100	10	80	53.5	14	M16 x 2.0 36 deep
M0951	310	250	40	365	340	225	-	160	90	372	200	433	394	23	115	-	60	120	10	100	64	18	M20 x 2.5 42 deep
M1051	370	290	45	440	400	250	-	185	110	428	225	505	446	27	140	155	70	140	15	110	74.5	20	M20 x 2.5 42 deep
M1351	410	340	50	490	450	265	-	220	110	470	242	563	483	34	140	155	90	170	15	140	95	25	M24 x 3.0 50 deep
M1451	500	380	50	590	530	300	-	260	150	546	278	630	551	41	140	155	100	210	15	180	106	28	M24 x 3.0 50 deep

MOTOR FRAME SIZE	M0352	M0452	M0552	M0652	M0752	M0852	M0951	M1051	M1351	M1451
	K1	K1	K1	K1	K1	K1	K1	K1	K1	K1
63	441	507	735	756	575	682	763	869	990	1105
71	445	511	742	763	579	686	767	875	996	1111
80	458	524	773	794	592	699	780	893	1014	1129
90	468	534	804	825	602	709	790	903	1024	1139
100	-	-	-	-	-	-	-	930	1051	1166
112	-	-	-	-	-	-	-	930	1051	1166

kb - for brake motors
g2 - hand release if required

all parallel keys are to DIN 6885

SERIES M

DIMENSIONS - DOUBLE REDUCTION FLANGE MOUNT

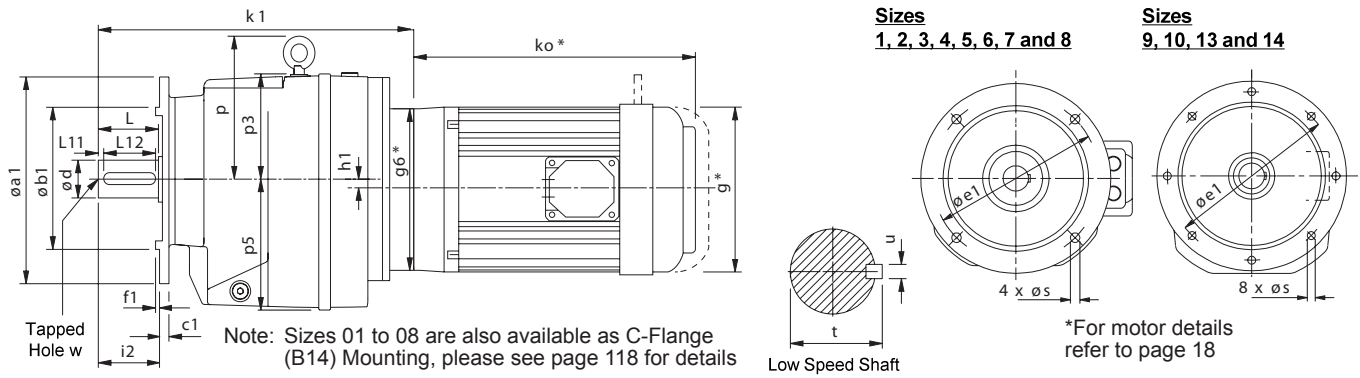

Size	Øa1	Øb1	c1	Øe1	f1	h1	i2	p	p3	p5	s	Low Speed Shaft						
												d	L	L11	L12	t	u	w
M0122	120	80	9	100	3	-	40	-	74	76	9	20 k6	40	4	32	22.5	6	M6 x 1 16 deep
	140	95	9	115	3	-	40	-	74	76	9							
	160	110	10	130	3.5	-	40	-	74	76	9							
	200	130	10	165	3.5	-	40	-	74	76	11							
M0222	120	80	10	100	3	-	50	-	90	91	6.6	25 k6	50	4	40	28	8	M10 x 1.5 16 deep
	140	95	10	115	3	-	50	-	90	91	9							
	160	110	10	130	3.5	-	50	-	90	91	9							
	200	130	10	165	3.5	-	50	-	90	91	11							
M0322	120	80	10	100	3	-	50	-	90	91	6.6	25 k6	50	4	40	28	8	M10 x 1.5 16 deep
	140	95	10	115	3	-	50	-	90	91	9							
	160	110	10	130	3.5	-	50	-	90	91	9							
	200	130	10	165	3.5	-	50	-	90	91	11							
M0422	140	95	11	115	3	-	60	-	93	115	9	30 k6	60	4	50	33	8	M10 x 1.5 16 deep
	160	110	11	130	3.5	-	60	-	93	115	9							
	200	130	11	165	3.5	-	60	-	93	115	11							
	250	180	11	215	4	-	60	-	93	115	13.5							
M0522	140	95	11	115	3	-	70	-	93	115	9	35 k6	70	7	60	38	10	M12 x 1.75 28 deep
	160	110	11	130	3.5	-	70	-	93	115	9							
	200	130	11	165	3.5	-	70	-	93	115	11							
	250	180	11	215	4	-	70	-	93	115	13.5							
M0622	200	130	11	165	4	14.5	70	116	84	130	11	35 k6	70	7	60	38	10	M12 x 1.75 28 deep
	250	180	11	215	4	14.5	70	116	84	130	13.5							
	300	230	11	265	4	14.5	70	116	84	130	13.5							
M0722	200	130	11	165	3.5	-	80	155	110	140	11	40 k6	80	5	70	43	12	M16 x 2.0 36 deep
	250	180	11	215	4	-	80	155	110	140	13.5							
	300	230	11	265	4	-	80	155	110	140	13.5							
M0822	300	230	17	265	4	-	100	180	130	182	13.5	50 k6	100	10	80	53.5	14	M16 x 2.0 36 deep
	350	250	17	300	5	-	100	180	130	182	17.5							
M0921	450	350	18	400	5	-	140	198	-	230	18	60 m6	120	10	100	64	18	M20 x 2.5 42 deep
M1021	450	350	22	400	5	-	140	245	-	260	18	60 m6	140	15	110	74.5	20	M20 x 2.5 42 deep
M1321	550	450	25	500	5	-	170	288	-	278	18	90 m6	170	15	140	95	25	M24 x 3.0 50 deep
M1421	550	450	25	500	5	-	210	320	-	318	18	100 m6	210	15	180	106	28	M24 x 3.0 50 deep

MOTOR FRAME SIZE	M0122	M0222	M0322	M0422	M0522	M0622	M0722	M0822	M0921	M1021	M1321	M1421
	K1	K1	K1	K1	K1	K1	K1	K1	K1	K1	K1	K1
63	209	240	240	270	280	301	-	-	-	-	-	-
71	213	244	244	276	286	307	-	-	-	-	-	-
80	226	257	257	294	304	325	362	477	523	-	-	-
90	236	267	267	304	314	335	372	477	523	-	-	-
100	244	275	275	331	341	362	384	483	529	596	717	832
112	244	275	275	331	341	362	384	483	529	596	717	832
132	-	-	-	331	733	362	406	483	564	596	717	832
160	-	-	-	-	-	-	414	513	564	631	710	825
180	-	-	-	-	-	-	-	-	564	564	710	825
200	-	-	-	-	-	-	-	-	564	564	710	825
225	-	-	-	-	-	-	-	-	591	591	737	852
250	-	-	-	-	-	-	-	-	-	-	909	1024
280	-	-	-	-	-	-	-	-	-	-	909	1024

kb - for brake motors
g2 - hand release if required

all parallel keys are to DIN 6885

SERIES M

DIMENSIONS - TRIPLE REDUCTION FLANGE MOUNT

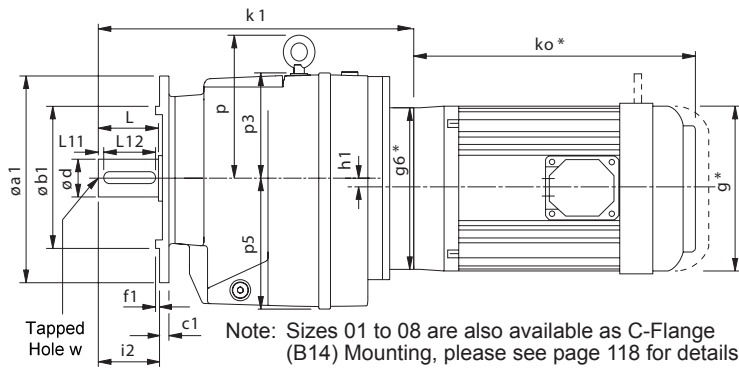

Sizes
1, 2, 3, 4, 5, 6, 7 and 8

Sizes
9, 10, 13 and 14

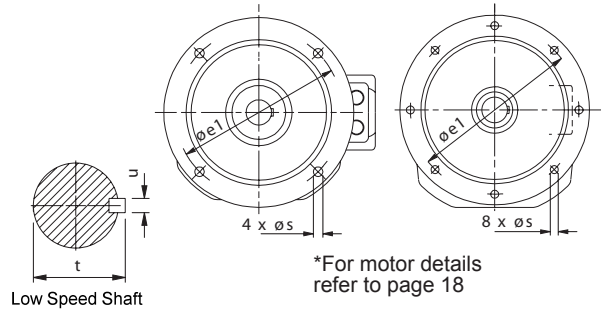

Size	$\phi a1$	$\phi b1$	c1	$\phi e1$	f1	h1	i2	p	p3	p5	s	Low Speed Shaft						
												d	L	L11	L12	t	u	w
M0132	120	80	9	100	3	-	40	-	74	76	9	20 k6	40	4	32	22.5	6	M6 x 1 16 deep
	140	95	9	115	3	-	40	-	74	76	9							
	160	110	10	130	3.5	-	40	-	74	76	9							
	200	130	10	165	3.5	-	40	-	74	76	11							
M0232	120	80	10	100	3	-	50	-	90	91	6.6	25 k6	50	4	40	28	8	M10 x 1.5 16 deep
	140	95	10	115	3	-	50	-	90	91	9							
	160	110	10	130	3.5	-	50	-	90	91	9							
	200	130	10	165	3.5	-	50	-	90	91	11							
M0332	120	80	10	100	3	-	50	-	90	91	6.6	25 k6	50	4	40	28	8	M10 x 1.5 16 deep
	140	95	10	115	3	-	50	-	90	91	9							
	160	110	10	130	3.5	-	50	-	90	91	9							
	200	130	10	165	3.5	-	50	-	90	91	11							
M0432	140	95	11	115	3	-	60	-	93	115	9	30 k6	60	4	50	33	8	M10 x 1.5 16 deep
	160	110	11	130	3.5	-	60	-	93	115	9							
	200	130	11	165	3.5	-	60	-	93	115	11							
	250	180	11	215	4	-	60	-	93	115	13.5							
M0532	140	95	11	115	3	-	70	-	93	115	9	35 k6	70	7	60	38	10	M12 x 1.75 28 deep
	160	110	11	130	3.5	-	70	-	93	115	9							
	200	130	11	165	3.5	-	70	-	93	115	11							
	250	180	11	215	4	-	70	-	93	115	13.5							
M0632	200	130	11	165	4	14.5	70	116	84	130	11	35 k6	70	7	60	38	10	M12 x 1.75 28 deep
	250	180	11	215	4	14.5	70	116	84	130	13.5							
	300	230	11	265	4	14.5	70	116	84	130	13.5							
M0732	200	130	11	165	3.5	-	80	155	110	140	11	40 k6	80	5	70	43	12	M16 x 2.0 36 deep
	250	180	11	215	4	-	80	155	110	140	13.5							
	300	230	11	265	4	-	80	155	110	140	13.5							
M0832	300	230	17	265	4	-	100	180	130	182	13.5	50 k6	100	10	80	53.5	14	M16 x 2.0 36 deep
	350	250	17	300	5	-	100	180	130	182	17.5							
M0931	450	350	18	400	5	-	140	198	-	230	18	60 m6	120	10	100	64	18	M20 x 2.5 42 deep
M1031	450	350	22	400	5	-	140	245	-	260	18	70 m6	140	15	110	74.5	20	M20 x 2.5 42 deep
M1331	550	450	25	500	5	-	170	288	-	278	18	90 m6	170	15	140	95	25	M24 x 3.0 50 deep
M1431	550	450	25	500	5	-	210	320	-	318	18	100 m6	210	15	180	106	28	M24 x 3.0 50 deep

MOTOR FRAME SIZE	M0132	M0232	M0332	M0432	M0532	M0632	M0732	M0832	M0931	M1031	M1331	M1431
	K1	K1	K1	K1	K1	K1	K1	K1	K1	K1	K1	K1
63	224	253	253	300	310	331	353	-	-	-	-	-
71	228	257	257	304	314	335	359	-	-	-	-	-
80	241	270	270	317	327	348	377	462	549	647	-	-
90	251	280	280	327	337	358	387	472	549	647	-	-
100	259	288	288	335	345	366	414	484	555	653	779	904
112	259	288	288	335	345	366	414	484	555	653	779	904
132	-	-	-	-	-	-	414	506	-	653	779	904
160	-	-	-	-	-	-	-	-	-	688	772	897
180	-	-	-	-	-	-	-	-	-	688	772	897
200	-	-	-	-	-	-	-	-	-	688	772	897
225	-	-	-	-	-	-	-	-	-	715	799	924
250	-	-	-	-	-	-	-	-	-	-	971	1096
280	-	-	-	-	-	-	-	-	-	-	971	1096

kb - for brake motors
g2 - hand release if required

all parallel keys are to DIN 6885

SERIES M

DIMENSIONS - QUADRUPLE REDUCTION FLANGE MOUNT

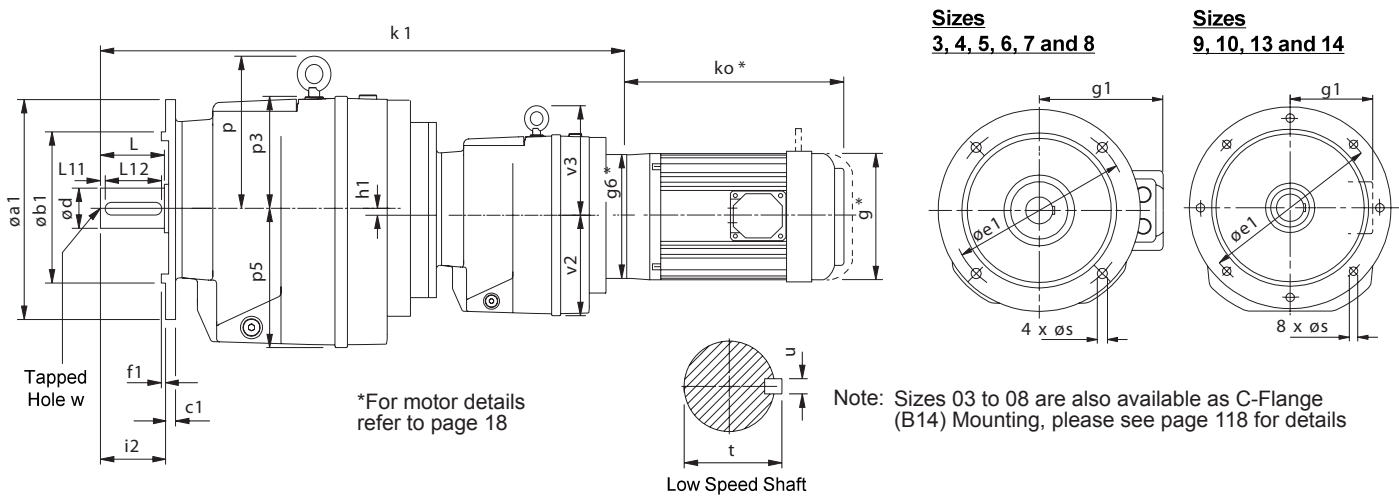

Size	Øa1	Øb1	c1	Øe1	f1	h1	i2	p	p3	p5	s	v2	v3	Low Speed Shaft						
														d	L	L11	L12	t	u	w
M0342	120	80	10	100	3	-	50	-	89	91	6.6	76	-	25	50	4	40	28	8	M10 x 1.5 22 deep
	140	95	10	115	3	-	50	-	89	91	9	76	-	25	50	4	40	28	8	
	160	110	10	130	3.5	-	50	-	89	91	9	76	-	25	50	4	40	28	8	
	200	130	10	165	3.5	-	50	-	89	91	11	76	-	25	50	4	40	28	8	
M0442	140	95	11	115	3	-	60	-	91	115	9	91	-	30	60	4	50	33	8	M10 x 1.5 22 deep
	160	110	11	130	3.5	-	60	-	91	115	9	91	-	30	60	4	50	33	8	
	200	130	11	165	3.5	-	60	-	91	115	11	91	-	30	60	4	50	33	8	
	250	180	11	215	4	-	60	-	91	115	13.5	91	-	30	60	4	50	33	8	
M0542	140	95	11	115	3	-	70	-	91	115	9	91	-	35	70	7	60	38	10	M12 x 1.75 28 deep
	160	110	11	130	3.5	-	70	-	91	115	9	91	-	35	70	7	60	38	10	
	200	130	11	165	3.5	-	70	-	91	115	11	91	-	35	70	7	60	38	10	
	250	180	11	215	4	-	70	-	91	115	13.5	91	-	35	70	7	60	38	10	
M0642	200	130	11	165	4	14.5	70	113	81	130	11	91	-	35	70	7	60	38	10	M12 x 1.75 28 deep
	250	180	11	215	4	14.5	70	113	81	130	13.5	91	-	35	70	7	60	38	10	
	300	230	11	265	4	14.5	70	113	81	130	13.5	91	-	35	70	7	60	38	10	
M0742	200	130	11	165	3.5	-	80	152	107	140	11	91	-	40	80	5	70	43	12	M16 x 2.0 36 deep
	250	180	11	215	4	-	80	152	107	140	13.5	91	-	40	80	5	70	43	12	
	300	230	11	265	4	-	80	152	107	140	13.5	91	-	40	80	5	70	43	12	
M0842	300	230	17	265	4	-	100	175	125	182	13.5	115	-	50	100	10	80	53.5	14	M16 x 2.0 36 deep
	350	250	17	300	5	-	100	175	125	182	17.5	115	-	50	100	10	80	53.5	14	
M0941	450	350	18	400	5	-	140	198	-	230	18	140	-	60 m6	120	10	100	64	18	M20 x 2.5 42 deep
M1041	450	350	22	400	5	-	140	245	-	260	18	140	155	70 m6	140	15	110	74.5	20	M20 x 2.5 42 deep
M1341	550	450	25	500	5	-	170	288	-	278	18	140	155	90 m6	170	15	140	95	25	M20 x 3.0 50 deep
M1441	550	450	25	500	5	-	210	320	-	318	18	140	155	100 m6	210	15	180	106	28	M20 x 3.0 50 deep

MOTOR FRAME SIZE	M0342	M0442	M0542	M0642	M0742	M0842	M0941	M1041	M1341	M1441
	K1	K1	K1	K1	K1	K1	K1	K1	K1	K1
63	426	494	504	525	562	652	733	-	-	-
71	430	498	508	529	566	658	739	-	-	-
80	443	511	521	542	579	676	757	878	999	1114
90	453	521	531	552	589	686	767	888	1009	1124
100	-	-	-	-	-	713	794	900	1021	1136
112	-	-	-	-	-	713	794	900	1021	1136
132	-	-	-	-	-	713	794	922	1043	1158
160	-	-	-	-	-	-	-	930	1051	1166

kb - for brake motors
g2 - hand release if required

all parallel keys are to DIN 6885

SERIES M

DIMENSIONS - QUINTUPLE REDUCTION FLANGE MOUNT

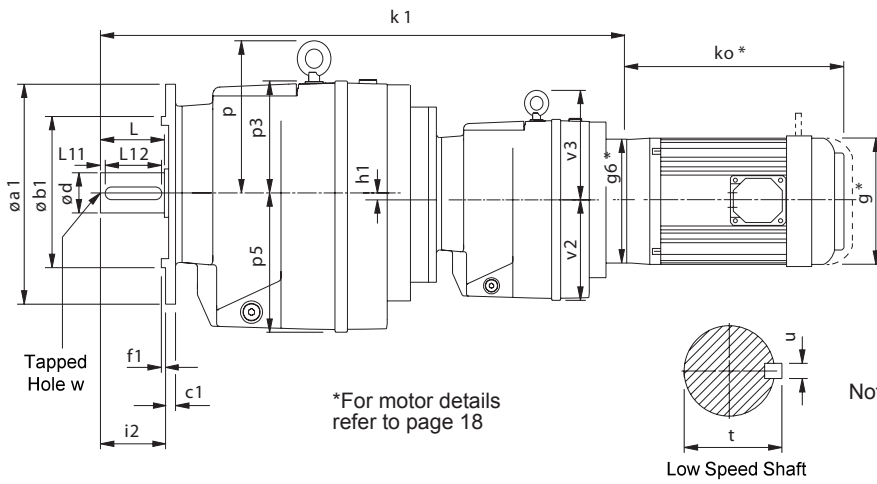

*For motor details refer to page 18

Sizes
3, 4, 5, 6, 7 and 8

Sizes
9, 10, 13 and 14

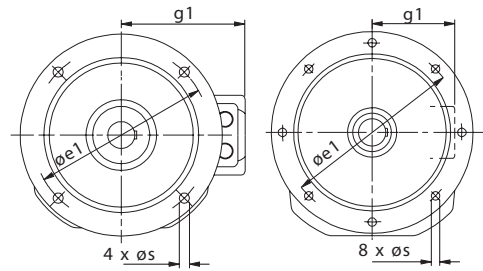

Note: Sizes 03 to 08 are also available as C-Flange (B14) Mounting, please see page 118 for details

Size	$\varnothing a1$	$\varnothing b1$	c1	$\varnothing e1$	f1	h1	i2	p	p3	p5	s	v2	v3	Low Speed Shaft						
														d	L	L11	L12	t	u	w
M0352	120	80	10	100	3	-	50	-	89	91	6.6	76	-	25 k6	50	4	40	28	8	M10 x 1.5 22 deep
	140	95	10	115	3	50	-	9	9											
	160	110	10	130	3.5	50	-	9	9											
	200	130	10	165	3.5	50	-	11	11											
M0452	140	95	11	115	3	-	60	-	91	115	9	91	-	30 k6	60	4	50	33	8	M10 x 1.5 22 deep
	160	110	11	130	3.5	60	-	9	9											
	200	130	11	165	3.5	60	-	11	11											
	250	180	11	215	4	60	-	13.5	13.5											
M0552	140	95	11	115	3	-	70	-	91	115	9	91	-	35 k6	70	7	60	38	10	M12 x 1.75 28 deep
	160	110	11	130	3.5	70	-	9	9											
	200	130	11	165	3.5	70	-	11	11											
	250	180	11	215	4	70	-	13.5	13.5											
M0652	200	130	11	165	4	14.5	70	113	81	130	11	91	-	35 k6	70	7	60	38	10	M12 x 1.75 28 deep
	250	180	11	215	4		70				13.5									
	300	230	11	265	4		70				13.5									
M0752	200	130	11	165	3.5	-	80	152	107	140	11	91	-	40 k6	80	5	70	43	12	M16 x 2.0 36 deep
	250	180	11	215	4	80	13.5													
	300	230	11	265	4	80	13.5													
M0852	300	230	17	265	4	-	100	175	125	182	13.5	115	-	50 k6	100	10	80	53.5	14	M16 x 2.0 36 deep
	350	250	17	300	5	100	17.5													
M0951	450	350	18	400	5	-	140	198	-	230	18	115	-	60 m6	120	10	100	64	18	M20 x 2.5 42 deep
M1051	450	350	22	400	5	-	140	245	-	260	18	140	155	70 m6	140	15	110	74.5	20	M20 x 2.5 42 deep
M1351	550	450	25	500	5	-	170	288	-	278	18	140	155	90 m6	170	15	140	95	25	M20 x 3.0 50 deep
M1451	550	450	25	500	5	-	210	320	-	318	18	140	155	100 m6	210	15	180	106	28	M20 x 3.0 50 deep

MOTOR FRAME SIZE	M0352	M0452	M0552	M0652	M0752	M0852	M0951	M1051	M1351	M1451
	K1	K1	K1	K1	K1	K1	K1	K1	K1	K1
63	441	507	735	756	575	682	763	869	990	1105
71	445	511	742	763	579	686	767	875	996	1111
80	458	524	773	794	592	699	780	893	1014	1129
90	468	534	804	825	602	709	790	903	1024	1139
100	-	-	-	-	-	-	-	930	1051	1166
112	-	-	-	-	-	-	-	930	1051	1166

kb - for brake motors
g2 - hand release if required

all parallel keys are to DIN 6885

MOTORISED BACKSTOP MODULE

Motorised backstop modules can be fitted between the gear unit and motor. The backstop device incorporates high quality centrifugal lift off sprags which are wear free above the lift off speed (n min). To ensure correct operation motor speed must exceed lift off speed.

Suitable for ambient temperature -40°C to + 50°C

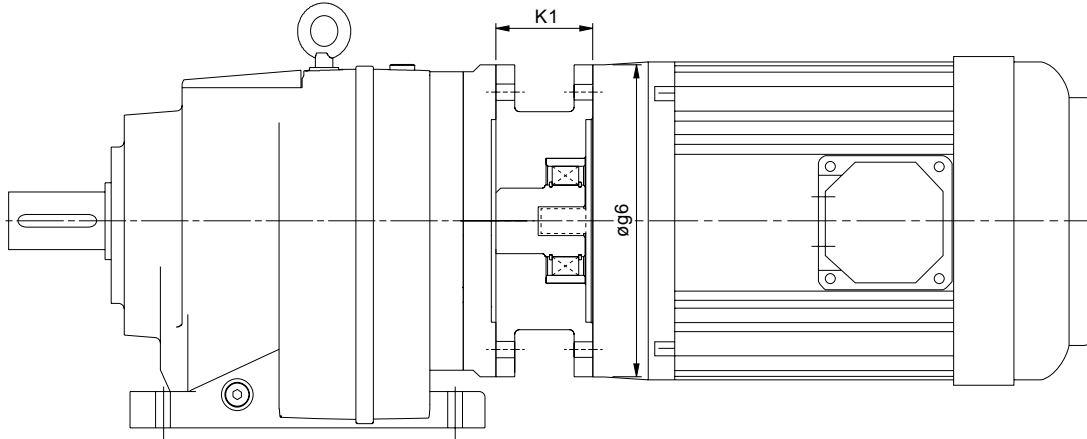

Warning

Removal of motor or backstop will release the drive. Ensure all driven machinery is secure prior to any maintenance work

IEC B5 FLANGE

Motor Frame Size	Lift off Speed ('n' min) (rev/min)	Rated Locking Torque ('T max') (at motor) (Nm)	øg6	K1
100	670	170	250	70
112	670	170	250	70
132	620	940	300	95
160	620	940	350	130
180	620	940	350	130
200	550	1260	400	130

NEMA C FLANGE

Motor Frame Size	Lift off Speed ('n' min) (rev/min)	Rated Locking Torque ('T max') (at motor) (Nm)	øg6	K1
182TC / 184TC	670	300	228	95.25
213TC / 215 TC	670	300	228	95.25
254TC / 256TC	620	940	228	120.65
284TC / 286TC	620	940	280	136.5
324TC / 326TC	550	1260	330	152.4

When a backstop module is fitted dimension K1 should be added to the overall length of the geared motor assembly.

Rotation of outputshaft must be specified when ordering as viewed from the outputshaft end (as shown in the diagram) see page 20 for column 20 entry

- | | | | | |
|----|---|---------------|---|---------------|
| CW | - | Free Rotation | - | Clockwise |
| | | Locked | - | Anticlockwise |
| AC | - | Free Rotation | - | Anticlockwise |
| | | Locked | - | Clockwise |

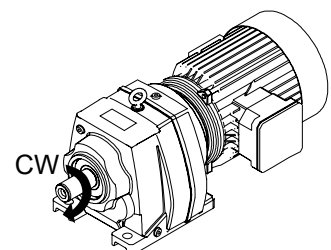

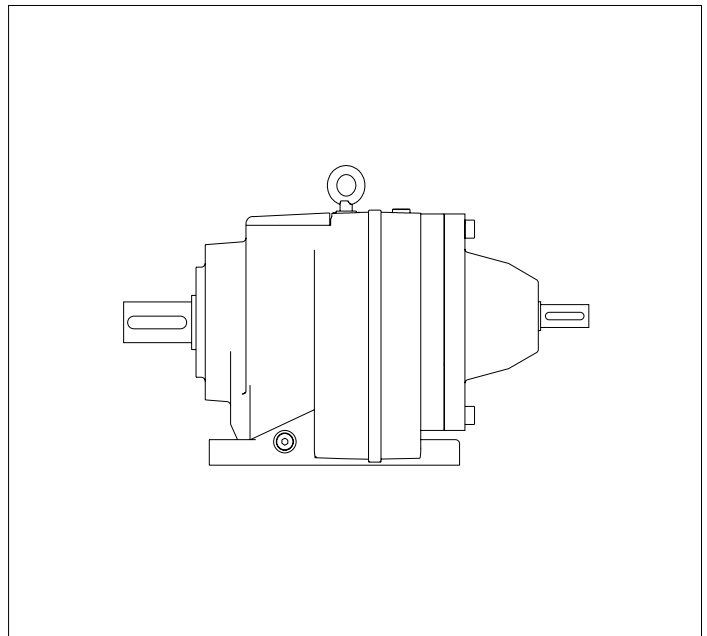

REDUCER
SERIES M

SERIES M

OVERHUNG & AXIAL LOADS (NEWTONS) ON SHAFTS

Maximum permissible overhung loads

When a sprocket, gear etc. is mounted on the shaft a calculation, as below, must be made to determine the overhung load on the shaft, and the results compared to the maximum permissible overhung loads tabulated. Overhung loads can be reduced by increasing the diameter of the sprocket, gear, etc. If the maximum permissible overhung load is exceeded, the sprocket, gear, etc. should be mounted on a separate shaft, flexibly coupled and supported in its own bearings, or the gear unit shaft should be extended to run in an outboard bearing. Alternatively, a larger gear is often a less expensive solution.

Permissible overhung loads vary according to the direction of rotation. The values tabulated are for the most unfavourable direction with the unit transmitting full rated power and the load P applied midway along the shaft extension. Hence they can sometimes be increased for a more favourable direction of rotation, or if the power transmitted is less than the rated capacity of the gear unit, or if the load is applied nearer to the gear unit case. Refer to our Application Engineers for further details. In any event, the sprocket, gear etc. should be positioned as close as possible to the gear unit case in order to reduce bearing loads and shaft stresses, and to prolong life.

All units will accept 100% momentary overload on stated capacities.

Overhung load (Newtons)

$$P = \frac{\text{kW} \times 9,500,000 \times K}{N \times R}$$

where

- P = equivalent overhung load (Newtons)
 kW = power transmitted by the shaft (kilowatts)
 N = speed of shaft (rev/min)
 R = pitch radius of sprocket, etc. (mm)
 K = factor

Overhung member

K (factor)

Chain sprocket*	1.00
Spur or helical pinion	1.25
Vee belt sheave	1.50
Flat belt pulley	2.00

* If multistrand chain drives are equally loaded and the outer strand is further than dimension Fra output or Frb input, refer to our Application Engineers.

Note: 1 Newton = 0.101972 kp = 0.227809 lbf.

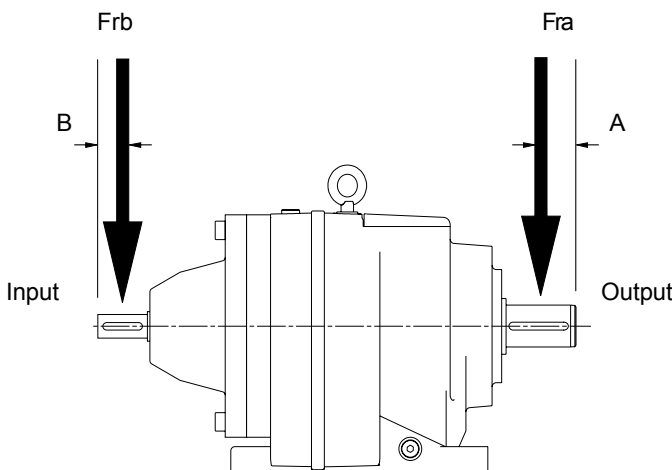

Distance midway along the shaft extension

Size of unit	No. of Reductions	Dimension A (mm)	Dimension B (mm)
M01	2 - 3	20	20
M02	2 - 3	25	20
M03	2 - 5	25	20
M04	2 - 5	30	20
M05	2 - 5	35	20
M06	2 - 5	35	20
M07	2	40	25
	3	40	20
	4 - 5	40	20
M08	2	50	30
	3	50	25
	4 - 5	50	20
M09	2	60	40
	3	60	30
	4 - 5	60	20
M10	2	70	55
	3	70	40
	4 - 5	70	25
M13	2 - 3	85	55
	4	85	25
	5	85	20
M14	2 - 3	105	55
	4	105	25
	5	105	20

SERIES M

OVERHUNG & AXIAL LOADS (NEWTONS) ON SHAFTS

Inputshaft Overhung Loads, Frb (Kn) 1450 rpm

Two, Three, Four and Five Stage Units

	M01	M02	M03	M04	M05	M06	M07	M08	M09	M10	M13	M14
2 Stage	1.5	1.65	1.56	1.2	1.1	0.9	1.65	1.5	1.5	2.55	6.9	7.1
3 stage	1.65	1.75	1.75	1.5	1.5	1.5	1.8	2.25	3.5	4.2	12	12
4 Stage	-	-	1.5	1.5	1.5	1.5	1.5	1.75	1.75	2.25	2.25	2.25
5 Stage	-	-	1.5	1.5	1.5	1.5	1.5	1.75	1.75	2.25	2.25	2.25

For output overhung load Fra consult ratings tables pages 21 to 81

Axial Thrust Capacities (Newtons)

No check or calculation is required for axial loads (F_A) towards or away from the unit up to 50% of the permissible overhung load. If the axial thrust considerably exceeds these values or if there is a combination of axial thrust loads and overhung loads please contact our Application Engineers.

SERIES M

DOUBLE REDUCTION RATINGS

SIZES M01 - M04

*P*_m - Input Power (kW) *N*₂ - Output Speed (rpm)
*M*₂ - Output Torque (Nm) *fra* - Overhung Load (kN)
i - Exact Ratio (:1)

DOUBLE REDUCTION

Column Entry	Input Speed N1 (rpm)	M0122					M0222					M0322					M0422				
		N2 (rpm)	<i>i</i> (:1)	M2 (Nm)	<i>P</i> _m (kW)	<i>fra</i> (kN)	N2 (rpm)	<i>i</i> (:1)	M2 (Nm)	<i>P</i> _m (kW)	<i>fra</i> (kN)	N2 (rpm)	<i>i</i> (:1)	M2 (Nm)	<i>P</i> _m (kW)	<i>fra</i> (kN)	N2 (rpm)	<i>i</i> (:1)	M2 (Nm)	<i>P</i> _m (kW)	<i>fra</i> (kN)
3 . 6	2900	773	3.75	47	3.97	0.98	808	3.589	79	7	3.00	808	3.589	96	8.45	2.05	809	3.585	161	14.2	2.05
	1450	387		59	2.49	0.98	404		100	4.39	3.10	404		118	5.18	2.30	404		203	8.87	2.30
	960	256		68	1.89	0.98	268		115	3.33	3.10	268		134	3.88	2.30	268		233	6.72	2.60
	725	193		73	1.53	0.98	202		126	2.74	3.10	202		146	3.18	2.30	202		256	5.57	3.45
5 . 0	2900	572	5.066	54	3.34	0.98	576	5.034	92	5.76	3.00	576	5.034	110	6.87	2.05	575	5.04	188	11.8	2.05
	1450	286		68	2.09	0.98	288		116	3.61	3.10	288		135	4.22	2.30	288		237	7.37	2.45
	960	190		76	1.55	0.98	191		131	2.7	3.10	191		153	3.16	2.30	190		272	5.59	3.20
	725	143		79	1.22	1.00	144		137	2.13	3.15	144		167	2.59	2.30	144		290	4.49	4.60
5 . 6	2900	503	5.762	57	3.1	0.98	523	5.547	96	5.44	3.05	523	5.547	114	6.47	2.05	513	5.649	198	11	2.05
	1450	252		71	1.95	0.98	261		121	3.41	3.10	261		140	3.97	2.30	257		249	6.91	2.60
	960	167		78	1.41	1.00	173		134	2.5	3.10	173		159	2.97	2.30	170		286	5.23	3.40
	725	126		82	1.11	1.02	131		140	1.97	3.15	131		173	2.44	2.30	128		298	4.12	4.70
6 . 3	2900	444	6.528	60	2.87	0.98	460	6.299	101	5.04	3.05	460	6.299	120	5.98	2.10	457	6.341	208	10.3	2.10
	1450	222		75	1.8	0.98	230		127	3.16	3.10	230		147	3.67	2.30	229		262	6.46	2.90
	960	147		80	1.27	1.00	152		138	2.27	3.10	152		167	2.74	2.32	151		294	4.79	4.60
	725	111		84	1.01	1.04	115		145	1.8	3.20	115		182	2.25	2.35	114		307	3.78	4.75
8 . 0	2900	347	8.348	66	2.48	0.98	362	8	111	4.36	3.10	362	8	130	5.13	2.10	360	8.053	229	8.94	2.30
	1450	174		79	1.49	0.98	181		136	2.67	3.10	181		161	3.15	2.30	180		289	5.61	3.45
	960	115		85	1.06	1.04	120		145	1.88	3.25	120		182	2.36	2.35	119		310	3.99	4.70
	725	87		90	0.84	1.18	91		154	1.51	3.50	91		198	1.93	2.40	90		326	3.16	5.10
9 . 0	2900	322	8.997	67	2.36	0.98	319	9.088	116	4.02	3.10	319	9.088	136	4.71	2.10	318	9.129	241	8.29	2.40
	1450	161		80	1.4	1.00	160		140	2.41	3.10	160		168	2.89	2.30	159		299	5.13	4.60
	960	107		87	1	1.09	106		150	1.71	3.40	106		190	2.17	2.35	105		319	3.61	4.85
	725	81		90	0.78	1.30	80		159	1.37	3.90	80		207	1.78	2.50	79		338	2.89	6.00
1 1 .	2900	255	11.359	74	2.04	0.98	260	11.154	125	3.53	3.10	260	11.154	146	4.11	2.10	266	10.887	258	7.44	2.60
	1450	128		84	1.16	1.02	130		145	2.04	3.15	130		179	2.52	2.30	133		311	4.46	4.70
	960	85		90	0.82	1.30	86		158	1.46	3.55	86		203	1.89	2.40	88		333	3.17	5.55
	725	64		90	0.62	1.45	65		160	1.12	4.00	65		209	1.47	2.75	67		338	2.42	6.40
1 2 .	2900	225	12.877	77	1.89	0.98	234	12.371	130	3.31	3.10	234	12.371	151	3.84	2.15	231	12.536	272	6.82	2.90
	1450	113		87	1.06	1.04	117		148	1.88	3.20	117		186	2.36	2.35	116		320	3.99	4.75
	960	75		90	0.72	1.40	78		160	1.34	3.70	78		209	1.75	2.55	77		338	2.79	6.00
	725	56		90	0.55	1.50	59		160	1.01	4.00	59		209	1.32	2.80	58		338	2.11	6.40
1 4 .	2900	197	14.715	80	1.7	0.98	206	14.054	136	3.05	3.10	206	14.054	158	3.52	2.15	199	14.58	288	6.2	3.10
	1450	99		90	0.96	1.09	103		153	1.71	3.30	103		194	2.16	2.35	99		329	3.53	4.85
	960	65		90	0.63	1.40	68		160	1.18	3.85	68		209	1.54	2.75	66		338	2.4	6.40
	725	49		90	0.48	1.50	52		160	0.89	4.00	52		209	1.16	2.85	50		338	1.81	6.70
1 6 .	2900	177	16.369	81	1.56	0.98	182	15.968	141	2.79	3.10	182	15.968	166	3.28	2.15	178	16.312	304	5.86	3.50
	1450	89		90	0.86	1.18	91		160	1.57	3.50	91		205	2.02	2.40	89		338	3.25	5.10
	960	59		90	0.57	1.45	60		160	1.04	4.00	60		209	1.36	2.80	59		338	2.15	6.50
	725	44		90	0.43	1.50	45		160	0.79	4.00	45		209	1.03	2.90	44		338	1.62	7.10
1 8 .	2900	161	18.047	83	1.44	1.00	165	17.584	142	2.54	3.10	165	17.584	169	3.03	2.30	167	17.386	306	5.52	4.50
	1450	80		90	0.78	1.35	82		160	1.43	3.90	82		208	1.86	2.45	83		338	3.04	5.55
	960	53		90	0.52	1.48	55		160	0.94	4.00	55		209	1.23	2.80	55		338	2.01	6.70
	725	40		90	0.39	1.60	41		160	0.71	4.00	41		209	0.93	3.05	42		338	1.52	7.20
2 0 .	2900	146	19.861	84	1.33	1.00	143	20.226	145	2.26	3.15	143	20.226	177	2.76	2.30	141	20.605	315	4.81	4.60
	1450	73		90	0.71	1.40	72		160	1.24	3.95	72		209	1.62	2.60	70		338	2.57	6.00
	960	48		90	0.47	1.50	47		160	0.82	4.00	47		209	1.07	2.90	47		338	1.7	7.10
	725	37		90	0.35	1.60	36		160	0.62	4.00	36		209	0.81	3.10	35		338	1.28	7.20
2 2 .	2900	125	23.269	86	1.17	1.02	132	21.989	147	2.11	3.15	132	21.989	182	2.61	2.30	132	22	319	4.56	4.70
	1450	62		90	0.61	1.45	66		160	1.14	4.00	66		209	1.49	2.75	66		338	2.41	6.40
	960	41		90	0.4	1.55	44		160	0.76	4.00	44		209	0.99	3.05	44		338	1.59	7.10
	725	31		90	0.3	1.90	33		160	0.57	4.00	33		209	0.75	3.10	33		338	1.2	7.20
2 8 .	2900	104	27.917	90	1.01	1.05	110	26.397	153	1.83	3.20	110	26.397	193	2.3	2.35	106	27.3	331	3.82	4.80
	1450	52		90	0.51	1.48	55		160	0.95	4.00	55		209	1.25	2.80	53		338	1.94	6.70
	960	34		90	0.34	1.60	36		160	0.63	4.00	36		209	0.82	3.10	35		338	1.29	7.20
	725	26		90	0.25	1.90	27		160	0.48	4.00	27		209	0.62	3.15	27		338	0.97	7.20
3 2 .	2900	89	32.542	90	0.87	1.18	92	31.677	160	1.59	3.50	92	31.677	205	2.04	2.40	90	32.192	338	3.31	5.10
	1450	45		90	0.44	1.50	46		160	0.8	4.00	46		209	1.04	2.90	45		338	1.65	7.10
	960	30		90	0.29	1.90	30		160	0.53	4.00	30		209	0.69	3.10	30		338	1.09	7.20
	725	22		90	0.22	1.90	23		160	0.4	4.00	23		209	0.52	3.15	23		338	0.82	7.20
3 6 .	2900	80	36.157	90	0.79	1.35	81	35.692	160	1.42	3.90	81	35.692	209	1.85	2.45	82	35.25	338	3.02	8.55
	1450	40		90	0.39	1.60	41		160	0.71	4.00	41		209	0.92	3.05	41		338	1.51	7.20
	960	27		90	0.26	1.90	27		160	0.47	4.00	27		209	0.61	3.15	27		338	1	7.20
	725	20		90	0.2	1.90	20		160	0.35	4.00	20		209	0.46	3.15	21		338		

SERIES M

DOUBLE REDUCTION RATINGS

SIZES M05 - M08

*P*_m - Input Power (kW) *N*₂ - Output Speed (rpm)
*M*₂ - Output Torque (Nm) *fra* - Overhung Load (kN)
i - Exact Ratio (:1)

DOUBLE REDUCTION

Column Entry	Input Speed <i>N</i> ₁ (rpm)	M0522					M0622					M0722					M0822				
		<i>N</i> ₂ (rpm)	<i>i</i> (:1)	<i>M</i> ₂ (Nm)	<i>P</i> _m (kW)	<i>fra</i> (kN)	<i>N</i> ₂ (rpm)	<i>i</i> (:1)	<i>M</i> ₂ (Nm)	<i>P</i> _m (kW)	<i>fra</i> (kN)	<i>N</i> ₂ (rpm)	<i>i</i> (:1)	<i>M</i> ₂ (Nm)	<i>P</i> _m (kW)	<i>fra</i> (kN)	<i>N</i> ₂ (rpm)	<i>i</i> (:1)	<i>M</i> ₂ (Nm)	<i>P</i> _m (kW)	<i>fra</i> (kN)
3 . 6	2900	809	3.585	263	23.1	2.80					789	3.678	304	26.1	3.50	788	3.678	479	41.3	5.50	
	1450	404		292	12.8	2.80				394	306		13.1	3.50	394	483		20.7	6.20		
	960	268		293	8.44	2.80				261	307		8.65	3.50	261	484		13.7	6.25		
	725	202		293	6.38	2.80				197	307		6.53	3.50	197	485		10.3	6.36		
5 . 0	2900	575	5.04	317	19.7	2.80	653	4.438	326	23.1	4.00	569	5.094	423	26.1	3.50	556	5.214	683	41.3	5.60
	1450	288		382	11.8	2.80	327		362	12.8	4.35	285		425	13.1	3.50	278		686	20.7	6.20
	960	190		383	7.84	2.80	216		363	8.44	4.45	188		425	8.65	3.50	184		688	13.7	6.35
	725	144		383	5.92	2.85	163		363	6.38	4.50	142		426	6.53	3.50	139		688	10.3	6.50
5 . 6	2900	513	5.649	336	18.6	2.80	465	6.24	393	19.7	4.10	507	5.722	447	24.5	3.50	501	5.792	760	41.3	5.80
	1450	257		409	11.3	2.80	232		473	11.8	4.45	253		477	13.1	3.50	250		763	20.7	6.25
	960	170		412	7.54	2.80	154		474	7.84	4.50	168		478	8.65	3.50	166		764	13.7	6.40
	725	128		413	5.69	2.85	116		474	5.92	5.00	127		478	6.53	3.50	125		765	10.3	6.60
6 . 3	2900	457	6.341	354	17.5	2.80	415	6.994	416	18.6	4.20	461	6.292	464	23.2	3.50	450	6.442	832	40.6	6.00
	1450	229		413	10.2	2.85	207		510	11.4	4.45	230		525	13.1	3.50	225		849	20.7	6.30
	960	151		413	6.74	2.90	137		511	7.54	4.60	153		526	8.65	3.50	149		851	13.7	6.50
	725	114		414	5.09	2.90	104		511	5.69	5.20	115		526	6.53	3.50	113		851	10.3	6.70
8 . 0	2900	360	8.053	381	14.8	2.80	369	7.851	438	17.5	4.30	353	8.218	519	19.9	3.50	348	8.33	926	34.9	6.20
	1450	180		441	8.55	2.85	185		512	10.2	4.45	176		655	12.5	3.50	174		1100	20.7	6.35
	960	119		450	5.77	2.90	122		512	6.74	4.70	117		687	8.65	3.50	115		1100	13.7	6.70
	725	90		450	4.36	2.95	92		512	5.09	5.20	88		687	6.53	3.60	87		1100	10.3	7.25
9 . 0	2900	318	9.129	391	13.4	2.80	291	9.97	484	15.2	4.35	310	9.344	547	18.4	3.50	310	9.352	967	32.5	6.20
	1450	159		450	7.69	2.90	145		594	9.3	4.50	155		689	11.5	3.50	155		1220	20.5	6.50
	960	105		450	5.09	2.95	96		594	6.15	5.20	103		743	8.24	3.50	103		1240	13.7	7.10
	725	79		450	3.84	3.00	73		594	4.64	6.50	78		780	6.52	3.70	78		1240	10.3	8.00
1 1 .	2900	266	10.887	406	11.7	2.80	257	11.302	507	14	4.45	256	11.346	589	16.3	3.50	253	11.469	1040	28.4	6.20
	1450	133		450	6.45	2.90	128		604	8.34	4.70	128		726	10	3.50	126		1310	17.9	6.60
	960	88		450	4.27	2.95	85		607	5.55	5.85	85		773	7.06	3.60	84		1500	13.6	7.50
	725	67		450	3.22	4.00	64		607	4.19	7.20	64		811	5.59	4.25	63		1520	10.3	9.00
1 2 .	2900	231	12.536	418	10.5	2.85	215	13.479	538	12.5	4.45	232	12.481	611	15.4	3.50	224	12.923	1060	25.8	6.30
	1450	116		426	5.31	2.90	108		613	7.11	5.20	116		740	9.28	3.60	112		1340	16.3	6.90
	960	77		427	3.52	3.25	71		625	4.79	6.50	77		793	6.58	3.70	74		1540	12.4	8.50
	725	58		427	2.66	4.20	54		625	3.62	7.20	58		819	5.13	4.20	56		1690	10.2	9.00
1 4 .	2900	199	14.58	432	9.28	2.85	187	15.52	527	10.6	4.45	202	14.342	644	14.1	3.50	193	15.043	1120	23.3	6.30
	1450	99		450	4.82	2.95	93		528	5.31	5.20	101		761	8.31	3.60	96		1410	14.7	6.90
	960	66		450	3.19	4.00	62		528	3.52	7.20	67		808	5.84	4.00	64		1620	11.2	9.00
	725	50		450	2.41	4.25	47		528	2.66	7.20	51		830	4.53	4.50	48		1700	8.82	9.50
1 6 .	2900	178	16.312	442	8.5	2.85	161	18.051	584	10.1	4.50	178	16.263	684	13.2	3.50	174	16.686	1150	21.7	6.38
	1450	89		450	4.32	2.95	80		596	5.16	5.85	89		786	7.58	3.50	87		1420	13.4	7.25
	960	59		450	2.86	4.10	53		597	3.42	7.20	59		818	5.22	4.20	58		1420	8.85	9.00
	725	44		450	2.16	4.50	40		597	2.58	7.20	45		841	4.05	4.65	43		1420	6.68	9.50
1 8 .	2900	167	17.386	448	8.08	2.90	144	20.196	598	9.28	4.50	162	17.938	700	12.3	3.50	159	18.261	1160	19.9	6.50
	1450	83		450	4.05	3.00	72		626	4.85	6.50	81		794	6.93	3.60	79		1360	11.7	8.00
	960	55		450	2.68	4.20	48		626	3.21	7.20	54		826	4.77	4.50	53		1360	7.74	9.25
	725	42		450	2.02	4.50	36		626	2.42	7.20	40		849	3.71	5.10	40		1360	5.85	10.00
2 0 .	2900	141	20.605	450	6.85	2.90	135	21.526	601	8.75	4.60	141	20.543	731	11.2	3.50	140	20.659	1200	18.3	6.50
	1450	70		450	3.42	3.50	67		626	4.55	7.20	71		804	6.14	3.90	70		1460	11.1	8.50
	960	47		450	2.26	4.50	45		626	3.01	7.20	47		837	4.23	4.60	46		1460	7.34	9.50
	725	35		450	1.71	5.60	34		626	2.27	7.20	35		861	3.28	6.25	35		1460	5.54	12.30
2 2 .	2900	132	22	450	6.41	2.90	114	25.511	610	7.5	4.90	125	23.226	748	10.1	3.50	124	23.32	1230	16.6	6.60
	1450	66		450	3.2	4.00	57		626	3.84	7.20	62		813	5.5	4.20	62		1540	10.3	9.00
	960	44		450	2.12	4.50	38		626	2.54	7.20	41		847	3.79	5.10	41		1540	6.84	10.00
	725	33		450	1.6	6.30	28		626	1.92	7.20	31		867	2.93	7.40	31		1540	5.16	12.30
2 8 .	2900	106	27.3	450	5.17	2.90	106	27.238	614	7.07	5.20	108	26.928	768	8.97	3.50	103	28.269	1260	14	6.90
	1450	53		450	2.58	4.25	53		626	3.6	7.20	54		825	4.81	4.50	51		1580	8.8	9.25
	960	35		450	1.71	5.60	35		626	2.38	7.20	36		860	3.32	6.25	34		1670	6.13	12.30
	725	27		450	1.29	7.20	27		626	1.8	7.20	27		867	2.53	8.00	26		1670	4.63	14.00
3 2 .	2900	90	32.192	450	4.39	2.95	86	33.8	626	5.81	5.80	90	32.118	786	7.7	3.50	88	32.967	1280	12.2	7.25
	1450	45		450	2.19	4.50	43		626	2.9	7.20	45		840	4.11	4.65	44		1620	7.72	9.50
	960	30		450	1.45	6.30	28		626	1.92	7.20	30		867	2.81	7.40	29		1700	5.36	13.50
	725	23		450	1.1	7.20	21		626	1.45	7.20	23		868	2.12	9.20	22		1700	4.04	16.20
3 6 .	2900	82	35.25	450	4.02	3.00	73	39.857	626	4.93	6.50	82	35.173	792	7.1	3.60	80	36.213	1310	11.4	8.00
	1450	41		450	2.01	5.00	36		626	2.47	7.20	41		847	3.79	5.10	40		1650	7.18	10.00
	960	27		450	1.33	7.20	24		626	1.63	7.20	27		867	2.57	8.00	27		1700	4.88	14.00
	725	21		450	1	7.20	18														

SERIES M

DOUBLE REDUCTION RATINGS

SIZES M09 - M14

Note: Input Power, Pm may exceed thermal limit,
Check thermal power page 119 -120

Pm - Input Power (kW)
M2 - Output Torque (Nm)
i - Exact Ratio (:1)

N2 - Output Speed (rpm)
fra - Overhung Load (kN)

DOUBLE REDUCTION

Column Entry	Input Speed N1 (rpm)	M0921					M1021					M1321					M1421							
		N2 (rpm)	i (:1)	M2 (Nm)	Pm (kW)	fra (kN)	N2 (rpm)	i (:1)	M2 (Nm)	Pm (kW)	fra (kN)	N2 (rpm)	i (:1)	M2 (Nm)	Pm (kW)	fra (kN)	N2 (rpm)	i (:1)	M2 (Nm)	Pm (kW)	fra (kN)			
1 . 4	2900	1961	1.479	452	96.1	10.0	2011	1.442	719	156	12.0													
	1450	980		574	60.6	10.0	1005		722	78.2	12.0													
	960	649		661	46	10.1	666		722	51.8	12.2													
	725	490		727	38.2	10.1	503		723	39.1	12.2													
1 . 8	2900	1424	2.036	534	82.2	10.0	1439	2.015	1010	156	12.0													
	1450	712		677	51.8	10.1	720		1010	78.2	12.2													
	960	471		779	39.3	10.1	476		1010	51.8	12.2													
	725	356		856	32.6	10.2	360		1010	39.1	12.3													
2 . 2	2900	1271	2.282	565	77.5	10.0	1323	2.191	1100	156	12.0													
	1450	635		716	48.8	10.1	662		1100	78.2	12.2													
	960	421		824	37.1	10.2	438		1100	51.8	12.3													
	725	318		906	30.8	10.2	331		1100	39.1	12.3													
2 . 5	2900	1132	2.562	596	72.9	10.0	1165	2.489	1170	147	12.0													
	1450	566		756	45.9	10.1	583		1250	78.2	12.2													
	960	375		869	34.9	10.2	386		1250	51.8	12.3													
	725	283		956	28.9	10.4	291		1250	39.1	12.4													
2 . 8	2900	977	2.969	909	96.1	10.0	969	2.992	1490	156	12.0	999	2.904	1810	195	28.0	1004	2.888	2520	274	35.0			
	1450	488		1150	60.6	10.1	485		1490	78.2	12.2	499		1810	97.4	28.7	502		2520	137	36.0			
	960	323		1320	46	10.2	321		1500	51.8	12.3	331		1810	64.5	29.5	332		2520	90.6	37.5			
	725	244		1460	38.2	10.4	242		1500	39.1	12.4	250		1810	48.7	30.0	251		2520	68.5	38.0			
3 . 2	2900	878	3.301	671	63.6	10.1	895	3.242	1310	126	12.2	909	3.189	1980	195	28.3	893	3.247	2840	274	35.5			
	1450	439		850	40	10.2	447		1570	75.2	12.3	455		1990	97.4	29.2	447		2840	137	37.0			
	960	291		978	30.4	10.4	296		1570	49.8	12.4	301		1990	64.5	30.0	296		2840	90.6	38.0			
	725	220		1070	25.2	10.6	224		1570	37.6	12.4	227		1990	48.7	31.0	223		2840	68.5	39.0			
3 . 6	2900	786	3.688	692	58.6	10.1	829	3.5	1330	118	12.2	797	3.638	2250	195	28.3	759	3.822	3320	274	35.5			
	1450	393		876	36.9	10.2	414		1570	69.7	12.3	399		2260	97.4	29.2	379		3330	137	37.0			
	960	260		1010	28.1	10.4	274		1570	46.1	12.4	264		2260	64.5	30.0	251		3330	90.6	38.0			
	725	197		1090	22.8	10.6	207		1570	34.8	12.4	199		2260	48.7	31.0	190		3330	68.5	39.0			
4 . 0	2900	709	4.088	1070	82.2	10.1	694	4.179	2090	156	12.2	720	4.025	2510	195	28.3	720	4.029	3520	274	35.5			
	1450	355		1360	51.8	10.2	347		2090	78.2	12.3	360		2510	97.4	29.5	360		3530	137	37.5			
	960	235		1560	39.3	10.6	230		2090	51.8	12.4	239		2510	64.5	31.0	238		3530	90.6	39.0			
	725	177		1710	32.6	10.8	173		2100	39.1	12.5	180		2510	48.7	32.5	180		3530	68.5	40.0			
4 . 5	2900	633	4.582	1130	77.5	10.1	638	4.545	2200	152	12.2	656	4.421	2760	195	28.3	639	4.537	3970	274	35.5			
	1450	316		1440	48.8	10.2	319		2280	78.2	12.3	328		2760	97.4	29.5	320		3970	137	37.5			
	960	210		1650	37.1	10.6	211		2280	51.8	12.4	217		2760	64.5	31.0	212		3970	90.6	39.0			
	725	158		1810	30.8	10.8	160		2280	39.1	12.5	164		2760	48.7	32.5	160		3970	68.5	40.0			
5 . 0	2900	572	5.073	1330	82.2	10.1	587	4.938	2260	144	12.2	575	5.042	3130	195	28.7	544	5.333	4650	274	36.0			
	1450	286		1680	51.8	10.4	294		2470	78.2	12.4	288		3140	97.4	30.0	272		4660	137	38.0			
	960	189		1930	39.3	10.8	194		2470	51.8	12.5	190		3140	64.5	32.5	180		4660	90.6	40.0			
	725	143		2120	32.6	11.0	147		2470	39.1	12.5	144		3140	48.7	35.0	136		4660	68.5	41.0			
5 . 6	2900	510	5.686	1410	77.5	10.1	540	5.37	2340	137	12.2	524	5.538	3440	195	28.7	483	6.005	5240	274	36.0			
	1450	255		1780	48.8	10.4	270		2690	78.2	12.4	262		3450	97.4	30.0	241		5240	137	38.0			
	960	169		2040	37.1	10.8	179		2690	51.8	12.5	173		3450	64.5	32.5	160		5240	90.6	40.0			
	725	128		2250	30.7	11.0	135		2690	39.1	12.5	131		3450	48.7	35.0	121		5240	68.5	41.0			
6 . 3	2900	438	6.628	1350	63.6	10.2	431	6.724	2550	119	12.3	467	6.21	3880	195	29.2	443	6.548	5730	274	37.0			
	1450	219		1700	40	10.6	216		3140	72.9	12.4	234		3880	97.4	31.0	221		5730	137	39.0			
	960	145		1960	30.4	11.0	143		3370	51.8	12.5	155		3880	64.5	35.0	147		5730	90.6	41.0			
	725	109		2150	25.2	11.4	108		3370	39.1	13.0	117		3880	48.7	38.0	111		5730	68.5	43.0			
7 . 1	2900	392	7.404	1390	58.6	10.2	399	7.26	2620	113	12.3	422	6.879	4300	195	29.2	399	7.27	6370	274	37.0			
	1450	196		1760	36.9	10.6	200		3230	69.5	12.4	211		4300	97.4	31.0	199		6360	137	39.0			
	960	130		2020	28.1	11.0	132		3640	51.8	12.5	140		4300	64.5	35.0	132		6360	90.6	41.0			
	725	98		2220	23.3	11.4	100		3640	39.1	13.0	105		4300	48.7	38.0	100		6370	68.5	43.0			
8 . 0	2900	353	8.224	1670	63.6	10.2	365	7.945	2700	107	12.3	373	7.779	4840	195	29.5	335	8.667	7570	274	37.5			
	1450	176		2080	39.5	10.8	182		3330	65.5	12.5	186		4840	97.4	32.5	167		7570	137	40.0			
	960	117		2360	29.6	11.4	121		3760	49	13.0	123		4840	64.5	38.0	111		7570	90.6	43.0			
	725	88		2560	24.3	13.0	91		3980	39.1	15.0	93		4850	48.7	42.0	84		7570	68.5	46.0			
9 . 0	2900	316	9.188	1720	58.6	10.2	338	8.578	2780	102	12.3	337	8.618	5110	186	29.5	301	9.623	8410	274	37.5			
	1450	158		2170	36.8	10.8	169		3420	62.4	12.5	168		5360	97.4	32.5	151		8400	137	40.0			
	960	104		2450	27.5	11.4	112		3870	46.7	13.0	111		5370	64.5	38.0	100		8400	90.6	43.0			
	725	79		2670	22.6	13.0	85		4210	38.3	15.0	84		5370	48.7	42.0	75		8410	68.5	46.0			
1 0 .	2900	282	10.266	1560	47.4	10.4	274	10.587	2990	88.3	12.4	293	9.891	5470	173	30.0	288	10.065	7980	248	38.0			
	1450	141		1970	29.8	11.0	137		3680	54.2	12.5	147		6170	97.4	35.0	144		8800	137	41.0			
	960	94		2260	22.7	13.0	91		3770	36.8	15.0	97		6180	64.5	42.0	95		8810	90.6	46.0			
	725	71		2480	18.8	15.																		

SERIES M

DOUBLE REDUCTION RATINGS

SIZES M09 - M14

Pm - Input Power (kW) *N2* - Output Speed (rpm)
M2 - Output Torque (Nm) *fra* - Overhung Load (kN)
i - Exact Ratio (:1)

DOUBLE REDUCTION

Column Entry			Input Speed N1 (rpm)	M0921					M1021					M1321					M1421				
				N2 (rpm)	i (:1)	M2 (Nm)	Pm (kW)	fra (kN)	N2 (rpm)	i (:1)	M2 (Nm)	Pm (kW)	fra (kN)	N2 (rpm)	i (:1)	M2 (Nm)	Pm (kW)	fra (kN)	N2 (rpm)	i (:1)	M2 (Nm)	Pm (kW)	fra (kN)
1	2	.	2900	228	12.739	1930	47.4	10.6	232	12.509	3160	79.1	12.4	234	12.391	5370	136	31.0	218	13.322	10200	241	39.0
			1450	114		2420	29.6	11.4	116		3890	48.6	13.0	117		6350	80.3	38.0	109		10200	121	43.0
			960	75		2740	22.2	13.0	77		4400	36.4	15.0	77		6350	53.2	42.0	72		10200	79.8	46.0
			725	57		2860	17.5	17.0	58		4410	27.5	23.0	59		6350	40.1	51.0	54		10200	60.2	60.0
1	4	.	2900	200	14.525	2000	43.1	10.6	205	14.161	3290	72.9	12.4	207	14.031	5880	131	31.0	192	15.127	10400	215	39.0
			1450	100		2530	27.1	11.4	102		4050	44.8	13.0	103		6290	70.3	38.0	96		10400	108	43.0
			960	66		2530	20.3	15.7	68		4410	32.2	15.9	68		6290	46.5	45.0	63		10400	71.3	52.0
			725	50		2860	15.3	17.0	51		4410	24.3	23.0	52		6290	35.1	51.0	48		10400	53.8	60.0
1	6	.	2900	175	16.591	1750	32.9	10.8	177	16.426	3460	65.9	12.5	182	15.969	6070	119	32.5	177	16.429	8970	172	40.0
			1450	87		2210	20.7	13.0	88		3770	35.9	15.0	91		6200	60.8	42.0	88		11100	106	46.0
			960	58		2530	15.7	17.0	58		3770	23.7	23.0	60		6200	40.2	51.0	58		11100	70.2	60.0
			725	44		2640	12.4	22.4	44		3770	17.9	28.0	45		6200	30.4	56.0	44		11100	53	70.0
1	8	.	2900	157	18.433	1760	29.9	10.8	159	18.253	3520	60.4	12.5	161	18	6200	108	32.5	160	18.112	9260	161	40.0
			1450	79		2230	18.9	13.0	79		3770	32.3	15.0	81		6200	53.9	42.0	80		11100	96.2	46.0
			960	52		2560	14.3	17.0	53		3770	21.4	23.0	53		6200	35.7	51.0	53		11100	63.7	60.0
			725	39		2640	11.2	22.4	40		3770	16.1	28.0	40		6200	26.9	56.0	40		11100	48.1	70.0
2	0	.	2900	141	20.588	2160	32.9	11.0	149	19.409	3650	58.9	12.5	145	20.005	5980	94.1	35.0	133	21.745	10600	153	41.0
			1450	70		2730	20.7	15.7	75		4410	35.6	15.9	72		6350	49.9	45.0	67		10600	76.7	52.0
			960	47		2860	14.3	22.4	49		4410	23.5	28.0	48		6350	33	56.0	44		10600	50.7	70.0
			725	35		2860	10.8	26.2	37		4410	17.8	34.0	36		6350	24.9	60.0	33		10600	38.3	79.0
2	2	.	2900	127	22.874	2190	29.9	11.0	134	21.568	3770	54.9	12.5	129	22.549	6350	88.6	35.0	121	23.974	10800	142	41.0
			1450	63		2760	18.9	15.7	67		4410	32	15.9	64		6350	44.3	45.0	60		10800	70.7	52.0
			960	42		2860	12.9	22.4	45		4410	21.2	28.0	43		6350	29.3	56.0	40		10800	46.8	70.0
			725	32		2860	9.75	26.2	34		4410	16	34.0	32		6350	22.1	60.0	30		10800	35.4	79.0
2	5	.	2900	111	26.037	1880	22.6	11.4	111	26.029	3760	45.2	13.0	114	25.455	6200	76.7	38.0	111	26.071	9530	115	43.0
			1450	56		2370	14.2	17.0	56		3770	22.7	23.0	57		6200	38.3	51.0	56		10600	63.8	60.0
			960	37		2640	10.5	26.2	37		3770	15	34.0	38		6200	25.4	60.0	37		10600	42.2	79.0
			725	28		2640	7.93	28.0	28		3770	11.3	40.0	28		6200	19.1	64.0	28		10600	31.9	79.0
2	8	.	2900	101	28.744	1900	20.7	11.4	97	29.992	3770	39.5	13.0	102	28.35	6200	68.9	38.0	103	28.247	9770	109	43.0
			1450	50		2400	13	17.0	48		3770	19.7	23.0	51		6200	34.4	51.0	51		9970	55.6	60.0
			960	33		2640	9.51	26.2	32		3770	13	34.0	34		6200	22.8	60.0	34		9980	36.8	79.0
			725	25		2640	7.18	28.0	24		3770	9.85	40.0	26		6200	17.2	64.0	26		9980	27.8	79.0
3	2	.	2900	90	32.31	2330	22.6	13.0	94	30.756	4220	43.1	15.0	91	31.888	6350	62.9	42.0	84	34.509	10700	97.6	46.0
			1450	45		2860	13.8	22.4	47		4410	22.5	28.0	45		6350	31.4	56.0	42		10700	48.8	70.0
			960	30		2860	9.16	28.0	31		4410	14.9	40.0	30		6350	20.8	64.0	28		10700	32.3	79.0
			725	22		2860	6.92	28.0	24		4410	11.2	40.0	23		6350	15.7	64.0	21		10700	24.4	79.0
3	6	.	2900	81	35.669	2350	20.7	13.0	82	35.438	4410	39.1	15.0	82	35.515	6350	56.6	42.0	78	37.388	10800	91.3	46.0
			1450	41		2860	12.5	22.4	41		4410	19.5	28.0	41		6350	28.3	56.0	39		10800	45.6	70.0
			960	27		2860	8.3	28.0	27		4410	12.9	40.0	27		6350	18.7	64.0	26		10800	30.2	79.0
			725	20		2860	6.26	28.0	20		4410	9.76	40.0	20		6350	14.1	64.0	19		10800	22.8	79.0
4	0	.	2900	72	40.252	2460	19.3	15.7	78	37.059	4160	35.3	15.9	74	39.008	6090	49.4	45.0	74	39.42	9400	75.7	52.0
			1450	36		2470	9.62	26.2	39		4160	17.6	34.0	37		6460	26.2	60.0	37		9940	39.9	79.0
			960	24		2470	6.37	28.0	26		4160	11.7	40.0	25		6460	17.4	64.0	24		10100	26.9	79.0
			725	18		2470	4.81	28.0	20		4160	8.82	40.0	19		6460	13.1	64.0	18		10100	20.3	79.0
4	5	.	2900	65	44.438	2470	17.4	15.7	68	42.7	4160	30.7	15.9	67	43.445	6160	45	45.0	68	42.709	9460	70.2	52.0
			1450	33		2470	8.71	26.2	34		4160	15.3	34.0	33		6460	23.6	60.0	34		10000	37.1	79.0
			960	22		2470	5.77	28.0	22		4160	10.1	40.0	22		6460	15.6	64.0	22		10100	24.8	79.0
			725	16		2470	4.35	28.0	17		4160	7.66	40.0	17		6460	11.8	64.0	17		10100	18.7	79.0
5	0	.	2900	59	49.069	2430	15.6	17.0	61	47.929	4250	27.9	23.0	60	48.629	5660	36.7	51.0	57	51.273	8130	50.1	60.0
			1450	30		2860	9.14	28.0	30		4260	14	40.0	30		5660	18.4	64.0	28		8140	25.1	79.0
			960	20		2860	6.05	28.0	20		4260	9.25	40.0	20		5660	12.2	64.0	19		8140	16.6	79.0
			725	15		2860	4.57	28.0	15		4260	6.98	40.0	15		5660	9.19	64.0	14		8140	12.5	79.0
5	6	.	2900	53	55.176	2120	12.1	17.0	56	51.494	3870	23.7	23.0	56	51.738	6020	36.7	51.0	50	57.515	8440	46.5	60.0
			1450	26		2000	5.71	28.0	28		3870	11.8	40.0	28		6030	18.4	64.0	25		8450	23.2	79.0
			960	17		1940	3.67	28.0	19		3870	7.84	40.0	19		6030	12.2	64.0	17		8450	15.4	79.0
			725	13		1910	2.72	28.0	14		3870	5.92	40.0	14		6030	9.19	64.0	13		8450	11.6	79.0
6	3	.	2900	47	61.131	2470	12.7	22.4	50	57.75	4160	22.7	28.0	49	59.488	6360	33.8	56.0	50	58.569	9270	50.1	70.0
			1450	24		2470	6.35	28.0	25		4160	11.4	40.0	24		6460	17.2	64.0	25		9270	25.1	79.0
			960	16		2470	4.21	28.0	17		4160	7.52	40.0	16		6460	11.4	64.0	16		9280	16.6	79.0
			725	12		2470	3.18	28.0	13		4160	5.68	40.0	12		6460	8.59	64.0	12		9280	12.5	79.0
7	1	.	2900	42	68.74	2470	11.3	22.4	47	62.045	4160	21.2	28.0	46	63.291	6400	32	56.0	44	65.7	9620	46.5	70.0
			1450	21		2470	5.66	28.0															

SERIES M

TRIPLE REDUCTION RATINGS

SIZES M01 - M04

Pm - Input Power (kW) *N2* - Output Speed (rpm)
M2 - Output Torque (Nm) *fra* - Overhung Load (kN)
i - Exact Ratio (:1)

TRIPLE REDUCTION

Column Entry	Input Speed N1 (rpm)	M0132					M0232					M0332					M0432				
		N2 (rpm)	i (:1)	M2 (Nm)	Pm (kW)	fra (kN)	N2 (rpm)	i (:1)	M2 (Nm)	Pm (kW)	fra (kN)	N2 (rpm)	i (:1)	M2 (Nm)	Pm (kW)	fra (kN)	N2 (rpm)	i (:1)	M2 (Nm)	Pm (kW)	fra (kN)
6 7 8	2900	50	58.461	90	0.5	1.50	51	57.027	159	0.89	4.00	51	57.027	209	1.17	2.80	50	58.382	287	1.57	6.70
	1450	25		90	0.25	1.90	25		160	0.45	4.00	25		209	0.58	3.15	25		338	0.92	7.20
	960	16		90	0.16	1.90	17		160	0.3	4.00	17		209	0.39	3.15	16		338	0.61	7.20
	725	12		90	0.12	1.90	13		160	0.22	4.00	13		209	0.29	3.15	12		338	0.46	7.20
6 3 .	2900	45	64.453	90	0.45	1.50	46	62.872	160	0.81	4.00	46	62.872	209	1.06	2.90	45	64.290	293	1.46	7.10
	1450	22		90	0.22	1.90	23		160	0.41	4.00	23		209	0.53	3.15	23		338	0.84	7.20
	960	15		90	0.15	1.90	15		160	0.27	4.00	15		209	0.35	3.15	15		338	0.55	7.20
	725	11		90	0.11	1.90	12		160	0.2	4.00	12		209	0.26	3.15	11		338	0.42	7.20
7 1 .	2900	41	70.933	90	0.41	1.60	42	69.193	160	0.74	4.00	42	69.193	209	0.97	3.00	39	73.950	302	1.31	7.20
	1450	20		90	0.2	1.90	21		160	0.37	4.00	21		209	0.48	3.15	20		338	0.73	7.20
	960	14		90	0.13	1.90	14		160	0.24	4.00	14		209	0.32	3.15	13		338	0.48	7.20
	725	10		90	0.1	1.90	10		160	0.18	4.00	10		209	0.24	3.15	9.8		338	0.36	7.20
8 0 .	2900	35	83.104	90	0.35	1.70	36	81.066	160	0.63	4.00	36	81.066	209	0.82	3.10	36	80.397	307	1.22	7.20
	1450	17		90	0.17	1.90	18		160	0.31	4.00	18		209	0.41	3.15	18		338	0.67	7.20
	960	12		90	0.12	1.90	12		160	0.21	4.00	12		209	0.27	3.15	12		338	0.44	7.20
	725	8.7		90	0.09	1.90	8.9		160	0.16	4.00	8.9		209	0.2	3.15	9.0		338	0.33	7.20
1 0 0	2900	29	99.702	90	0.29	1.90	30	97.257	160	0.53	4.00	30	97.257	209	0.69	3.15	30	96.516	324	1.07	7.20
	1450	15		90	0.14	1.90	15		160	0.26	4.00	15		209	0.34	3.15	15		338	0.56	7.20
	960	9.6		90	0.1	1.90	9.9		160	0.17	4.00	9.9		209	0.23	3.15	9.9		338	0.37	7.20
	725	7.3		90	0.07	1.90	7.5		160	0.13	4.00	7.5		209	0.17	3.15	7.5		338	0.28	7.20
1 1 2	2900	25	116.22	90	0.25	1.90	26	113.37	160	0.45	4.00	26	113.37	209	0.59	3.15	25	115.819	338	0.93	7.20
	1450	12		90	0.12	1.90	13		160	0.23	4.00	13		209	0.29	3.15	13		338	0.47	7.20
	960	8.3		90	0.08	1.90	8.5		160	0.15	4.00	8.5		209	0.19	3.15	8.3		338	0.31	7.20
	725	6.2		90	0.06	1.90	6.4		160	0.11	4.00	6.4		209	0.15	3.15	6.3		338	0.23	7.20
1 2 5	2900	22	129.134	90	0.22	1.90	23	125.967	160	0.41	4.00	23	125.967	209	0.53	3.15	22	130.500	338	0.83	7.20
	1450	11		90	0.11	1.90	12		160	0.2	4.00	12		209	0.27	3.15	11		338	0.41	7.20
	960	7.4		90	0.07	1.90	7.6		160	0.14	4.00	7.6		209	0.18	3.15	7.4		338	0.27	7.20
	725	5.6		90	0.06	1.90	5.6		160	0.1	4.00	5.6		209	0.13	3.15	5.6		338	0.21	7.20
1 6 0	2900	19	155.506	90	0.19	1.90	19	151.692	160	0.34	4.00	19	151.692	209	0.44	3.15	19	151.706	338	0.71	7.20
	1450	9.3		90	0.09	1.90	9.6		160	0.17	4.00	10		209	0.22	3.15	9.6		338	0.36	7.20
	960	6.2		90	0.06	1.90	6.3		160	0.11	4.00	6.3		209	0.15	3.15	6.3		338	0.23	7.20
	725	4.7		90	0.05	1.90	4.8		160	0.08	4.00	4.8		209	0.11	3.15	4.8		338	0.18	7.20
1 8 0	2900	16	178.241	90	0.16	1.90	17	173.87	160	0.29	4.00	17	173.87	209	0.39	3.15	17	172.188	338	0.63	7.20
	1450	8.1		90	0.08	1.90	8.3		160	0.15	4.00	8.3		209	0.19	3.15	8.4		338	0.31	7.20
	960	5.4		90	0.05	1.90	5.5		160	0.1	4.00	5.5		209	0.13	3.15	5.6		338	0.21	7.20
	725	4.1		90	0.04	1.90	4.2		160	0.07	4.00	4.2		209	0.1	3.15	4.2		338	0.16	7.20
2 0 0	2900	14	202.567	90	0.14	1.90	15	197.599	160	0.26	4.00	15	197.599	209	0.34	3.15	15	195.75	338	0.55	7.20
	1450	7.2		90	0.07	1.90	7.3		160	0.13	4.00	7.3		209	0.17	3.15	7.7		338	0.28	7.20
	960	4.7		90	0.05	1.90	4.9		160	0.09	4.00	4.9		209	0.11	3.15	4.9		338	0.18	7.20
	725	3.6		90	0.04	1.90	3.7		160	0.06	4.00	3.7		209	0.09	3.15	3.7		338	0.14	7.20

SERIES M

TRIPLE REDUCTION RATINGS

SIZES M09 - M14

Pm - Input Power (kW) *N2* - Output Speed (rpm)
M2 - Output Torque (Nm) *fra* - Overhung Load (kN)
i - Exact Ratio (:1)

TRIPLE REDUCTION

Column Entry			Input Speed N1 (rpm)	M0931			M1031			M1331			M1431										
				N2 (rpm)	i (:1)	M2 (Nm)	Pm (kW)	fra (kN)	N2 (rpm)	i (:1)	M2 (Nm)	Pm (kW)	fra (kN)	N2 (rpm)	i (:1)	M2 (Nm)	Pm (kW)	fra (kN)					
6	7	8																					
4	0	.	2900									73											
			1450									36	39.93	4380	35	45.0	70	41.36	7520	58.1	52.0		
			960									24		5530	21.9	60.0	35		9740	37.5	79.0		
			725									18		5940	15.6	64.0	23		10500	26.6	79.0		
4	5	.	2900																				
			1450										66	44.18	5360	38.9	45.0	60	48.21	9430	62.7	52.0	
			960										33		6170	22.2	60.0	30		11000	36.4	79.0	
			725										22		6350	15.1	64.0	20		11000	24.1	79.0	
5	0	.	2900																				
			1450											58	50.02	5460	35	51.0	53	54.75	9930	58.1	60.0
			960											29		6310	20.1	64.0	26		11000	32.1	79.0
			725										19		6350	13.4	64.0	18		11000	21.2	79.0	
5	6	.	2900	48	59.846	2100	11.2	17.0	48	60.229	3380	17.9	23.0	51	56.932	5270	29.6	51.0	49	59.456	8680	46.7	60.0
			1450	24		2590	6.84	28.0	24		3770	9.94	40.0	25		6190	17.3	64.0	24		10500	28.1	79.0
			960	16		2640	4.62	28.0	16		3770	6.57	40.0	17		6200	11.4	64.0	16		11000	19.7	79.0
			725	12		2640	3.49	28.0	12		3770	4.95	40.0	13		6200	8.63	64.0	12		11000	14.8	79.0
6	3	.	2900	44	66.489	2170	10.4	22.4	43	66.928	3490	16.6	28.0	45	64.174	5380	26.8	56.0	44	65.549	9020	44	70.0
			1450	22		2640	6.29	28.0	22		3770	8.95	40.0	23		6200	15.3	64.0	22		10700	26	79.0
			960	14		2640	4.16	28.0	14		3770	5.91	40.0	15		6200	10.1	64.0	15		11000	17.8	79.0
			725	11		2640	3.14	28.0	11		3770	4.46	40.0	11		6200	7.66	64.0	11		11000	13.5	79.0
7	1	.	2900	39	74.265	2350	10.1	22.4	41	71.167	3640	16.4	28.0	41	71.321	5920	26.6	56.0	37	78.698	11000	44.8	70.0
			1450	20		2860	6.1	28.0	20		4410	9.85	40.0	20		6350	14.2	64.0	18		11000	22.3	79.0
			960	13		2860	4.03	28.0	13		4410	6.51	40.0	13		6350	9.39	64.0	12		11000	14.8	79.0
			725	10		2860	3.04	28.0	10		4410	4.91	40.0	10		6350	7.09	64.0	9		11000	11.1	79.0
8	0	.	2900	35	82.508	2420	9.38	26.2	37	79.082	3760	15.2	34.0	36	80.394	6060	24.1	60.0	33	86.763	11000	40.7	79.0
			1450	18		2860	5.49	28.0	18		4410	8.87	40.0	18		6350	12.6	64.0	17		11000	20.3	79.0
			960	12		2860	3.63	28.0	12		4410	5.86	40.0	12		6350	8.33	64.0	11		11000	13.4	79.0
			725	9		2860	2.74	28.0	9		4410	4.42	40.0	9		6350	6.29	64.0	8		11000	10.1	79.0
9	0	.	2900	31	93.918	2400	8.15	26.2	30	95.441	3770	12.6	34.0	32	90.751	5930	20.9	60.0	31	94.354	10100	34.4	79.0
			1450	15		2640	4.46	28.0	15		3770	6.27	40.0	16		6200	10.9	64.0	15		11000	18.8	79.0
			960	10		2640	2.95	28.0	10		3770	4.15	40.0	11		6200	7.21	64.0	10		11000	12.4	79.0
			725	8		2640	2.23	28.0	8		3770	3.13	40.0	8		6200	5.44	64.0	8		11000	9.39	79.0
1	0	0	2900	28	103.683	2480	7.6	28.0	26	109.969	3770	10.9	40.0	29	101.074	6050	19.2	64.0	28	102.226	10300	32.2	79.0
			1450	14		2640	4.04	28.0	13		3770	5.45	40.0	14		6200	9.79	64.0	14		11000	17.3	79.0
			960	9		2640	2.67	28.0	9		3770	3.6	40.0	9		6200	6.48	64.0	9		11000	11.5	79.0
			725	7		2640	2.02	28.0	7		3770	2.72	40.0	7		6200	4.89	64.0	7		11000	8.66	79.0
1	1	2	2900	25	116.546	2690	7.36	28.0	26	112.773	4180	11.8	40.0	26	113.688	6350	18	64.0	23	124.89	11000	28.3	79.0
			1450	12		2860	3.89	28.0	13		4410	6.22	40.0	13		6350	8.95	64.0	12		11000	14.1	79.0
			960	8		2860	2.57	28.0	9		4410	4.11	40.0	8		6350	5.92	64.0	8		11000	9.34	79.0
			725	6		2860	1.94	28.0	6		4410	3.1	40.0	6		6350	4.47	64.0	6		11000	7.05	79.0
1	2	5	2900	23	128.664	2770	6.86	28.0	22	129.94	4360	10.7	40.0	23	126.62	6350	16.1	64.0	21	135.311	11000	26.1	79.0
			1450	11		2860	3.52	28.0	11		4410	5.4	40.0	11		6350	8.04	64.0	11		11000	13	79.0
			960	7		2860	2.33	28.0	7		4410	3.57	40.0	8		6350	5.32	64.0	7		11000	8.61	79.0
			725	6		2860	1.76	28.0	6		4410	2.7	40.0	6		6350	4.02	64.0	5		11000	6.5	79.0
1	4	0	2900	20	145.196	2470	5.46	28.0	21	135.882	4160	9.82	40.0	21	139.073	6460	15	64.0	20	142.663	10100	22.9	79.0
			1450	10		2470	2.71	28.0	11		4160	4.89	40.0	10		6460	7.47	64.0	10		10100	11.4	79.0
			960	7		2470	1.79	28.0	7		4170	3.23	40.0	7		6460	4.94	64.0	7		10100	7.54	79.0
			725	5		2470	1.35	28.0	5		4170	2.44	40.0	5		6460	3.73	64.0	5		10100	5.69	79.0
1	6	0	2900	18	160.292	2470	4.94	28.0	19	156.567	4160	8.53	40.0	19	154.892	6460	13.5	64.0	19	154.566	10100	21.1	79.0
			1450	9		2470	2.46	28.0	9		4170	4.25	40.0	9		6460	6.71	64.0	9		10100	10.5	79.0
			960	6		2470	1.62	28.0	6		4170	2.81	40.0	6		6460	4.44	64.0	6		10100	6.95	79.0
			725	5		2480	1.23	28.0	5		4200	2.13	40.0	5		6460	3.35	64.0	5		10100	5.25	79.0
1	8	0	2900	16	176.998	2860	5.15	28.0	17	175.738	4410	8.03	40.0	17	173.374	6350	11.7	64.0	16	185.558	11000	19	79.0
			1450	8		2860	2.57	28.0	8		4410	4	40.0	8		6350	5.86	64.0	8		11000	9.49	79.0
			960	5		2860	1.7	28.0	5		4410	2.65	40.0	6		6350	3.88	64.0	5		11000	6.28	79.0
			725	4		2860	1.28	28.0	4		4410	2	40.0	4		6350	2.93	64.0	4		11000	4.74	79.0
2	0	0	2900	15	199.029	2860	4.59	28.0	15	188.81	4410	7.48	40.0	16	184.459	6350	11	64.0	14	208.15	11000	17	79.0
			1450	7		2860	2.29	28.0	8		4410	3.73	40.0	8		6350	5.5	64.0	7		11000	8.48	79.0
			960	5		2860	1.51	28.0	5		4410	2.47	40.0	5		6350	3.64	64.0	5		11000	5.61	79.0
			725	4		2860	1.14	28.0	4		4410	1.86	40.0	4		6350	2.75	64.0	3		11000	4.23	79.0
2	2	5	2900	13	220.508	2470	3.59	28.0	14	211.75	4160	6.31	40.0	14	212.086	6460	9.8	64.0	14	211.965	10100	15.4	79.0
			1450	7		2470	1.79	28.0	7		4170	3.15	40.0	7		6460	4.89	64.0	7		10100	7.66	79.0
			960	4		2480	1.19	28.0	5		4210	2.1	40.0	5		6460	3.23	64.0	5		10100	5.07	79.0
			725	3		2480	0.89	28.0	3		4270	1.61	40.0	3		6460	2.44	64.0	3		10100	3.83	79.0
2	5	0	2900	12	247.956	2470																	

SERIES M

QUADRUPLE REDUCTION RATINGS

SIZES M03 - M07

Pm - Input Power (kW) *N2* - Output Speed (rpm)
M2 - Output Torque (Nm) *fra* - Overhung Load (kN)
i - Exact Ratio (:1)

QUADRUPLE REDUCTION

Column Entry	Input Speed N1 (rpm)	M0342					M0442					M0542					M0642					M0742				
		N2 (rpm)	i (:1)	M2 (Nm)	Pm (kW)	fra (kN)	N2 (rpm)	i (:1)	M2 (Nm)	Pm (kW)	fra (kN)	N2 (rpm)	i (:1)	M2 (Nm)	Pm (kW)	fra (kN)	N2 (rpm)	i (:1)	M2 (Nm)	Pm (kW)	fra (kN)	N2 (rpm)	i (:1)	M2 (Nm)	Pm (kW)	fra (kN)
2 2 5	2900	12.34	235	210	0.29	3.15	12.46	232.8	340	0.467	7.2	12.46	232.8	450	0.62	7.2					7.2	12.66	229	865	1.21	9.2
	1450	6.171		210	0.143	3.15	6.228		340	0.233	7.2	6.228		450	0.309	7.2					7.2	6.332		865	0.604	9.2
	960	4.086		210	0.095	3.15	4.124		340	0.155	7.2	4.124		450	0.205	7.2					7.2	4.192		865	0.4	9.2
	725	3.064		210	0.071	3.15	3.093		340	0.116	7.2	3.093		450	0.15	7.2					7.2	3.144		865	0.30	9.2
2 5 0	2900	11.10	261.4	210	0.26	3.15	11.13	260.5	340	0.417	7.2	11.13	260.5	450	0.55	7.2					7.2	11.17	259.7	865	0.53	9.2
	1450	5.548		210	0.128	3.15	5.567		340	0.209	7.2	5.567		450	0.276	7.2					7.2	5.584		865	0.532	9.2
	960	3.673		210	0.085	3.15	3.686		340	0.138	7.2	3.686		450	0.183	7.2					7.2	3.697		865	0.532	9.2
	725	2.755		210	0.064	3.15	2.764		340	0.104	7.2	2.764		450	0.14	7.2					7.2	2.773		865	0.53	9.2
2 8 0	2900	10.08	287.8	210	0.23	3.15	10.45	277.6	340	0.391	7.2	10.45	277.6	450	0.52	7.2	10.63	272.9	620	0.73	7.2	10.12	286.4	865	0.97	9.2
	1450	5.038		210	0.117	3.15	5.223		340	0.196	7.2	5.223		450	0.259	7.2	5.313		620	0.363	7.2	5.062		865	0.483	9.2
	960	3.335		210	0.077	3.15	3.458		340	0.13	7.2	3.458		450	0.172	7.2	3.518		620	0.24	7.2	3.352		865	0.32	9.2
	725	2.501		210	0.058	3.15	2.593		340	0.097	7.2	2.593		450	0.13	7.2	2.638		620	0.18	7.2	2.514		865	0.24	9.2
3 0 0	2900	9.14	317.3	210	0.212	3.15	9.486	305.7	340	0.355	7.2	9.486	305.7	450	0.47	7.2	9.238	313.9	620	0.63	7.2	9.194	315.4	865	0.88	9.2
	1450	4.569		210	0.106	3.15	4.743		340	0.178	7.2	4.743		450	0.235	7.2	4.619		620	0.316	7.2	4.597		865	0.438	9.2
	960	3.025		210	0.07	3.15	3.14		340	0.118	7.2	3.140		450	0.156	7.2	3.058		620	0.209	7.2	3.044		865	0.29	9.2
	725	2.269		210	0.053	3.15	2.355		340	0.088	7.2	2.355		450	0.12	7.2	2.294		620	0.16	7.2	2.283		865	0.22	9.2
3 6 0	2900	7.94	365	210	0.184	3.15	8.004	362.3	340	0.3	7.2	8.004	362.3	450	0.40	7.2	7.943	365.1	620	0.54	7.2	8.028	361.2	865	0.77	9.2
	1450	3.972		210	0.092	3.15	4.002		340	0.15	7.2	4.002		450	0.199	7.2	3.971		620	0.271	7.2	4.014		865	0.383	9.2
	960	2.630		210	0.061	3.15	2.65		340	0.099	7.2	2.650		450	0.131	7.2	2.629		620	0.18	7.2	2.658		865	0.253	9.2
	725	1.973		210	0.046	3.15	1.987		340	0.074	7.2	1.987		450	0.10	7.2	1.972		620	0.13	7.2	1.993		865	0.19	9.2
4 0 0	2900	7.22	401.7	210	0.167	3.15	6.959	416.8	340	0.261	7.2	6.959	416.8	450	0.35	7.2	7.306	396.9	620	0.50	7.2	6.980	415.5	865	0.67	9.2
	1450	3.610		210	0.084	3.15	3.479		340	0.13	7.2	3.479		450	0.173	7.2	3.653		620	0.25	7.2	3.490		865	0.333	9.2
	960	2.390		210	0.055	3.15	2.304		340	0.086	7.2	2.304		450	0.114	7.2	2.419		620	0.165	7.2	2.311		865	0.22	9.2
	725	1.792		210	0.041	3.15	1.728		340	0.065	7.2	1.728		450	0.086	7.2	1.814		620	0.12	7.2	1.733		865	0.17	9.2
4 5 0	2900	6.64	436.7	210	0.154	3.15	6.517	445	340	0.244	7.2	6.517	445	450	0.32	7.2	6.530	444.1	625	0.45	7.2	6.173	469.8	865	0.59	9.2
	1450	3.320		210	0.077	3.15	3.259		340	0.122	7.2	3.259		450	0.162	7.2	3.265		625	0.225	7.2	3.087		865	0.294	9.2
	960	2.198		210	0.051	3.15	2.157		340	0.081	7.2	2.157		450	0.107	7.2	2.162		625	0.149	7.2	2.044		865	0.195	9.2
	725	1.649		210	0.038	3.15	1.618		340	0.061	7.2	1.618		450	0.080	7.2	1.621		625	0.11	7.2	1.533		865	0.15	9.2
5 0 0	2900	5.67	511.7	210	0.131	3.15	5.995	483.8	340	0.225	7.2	5.995	483.8	450	0.297	7.2	5.440	533.1	625	0.375	7.2	5.678	510.7	865	0.541	9.2
	1450	2.834		210	0.066	3.15	2.997		340	0.112	7.2	2.997		450	0.149	7.2	2.720		625	0.187	7.2	2.839		865	0.271	9.2
	960	1.876		210	0.043	3.15	1.984		340	0.074	7.2	1.984		450	0.098	7.2	1.801		625	0.124	7.2	1.880		865	0.179	9.2
	725	1.407		210	0.033	3.15	1.488		340	0.056	7.2	1.488		450	0.074	7.2	1.351		625	0.093	7.2	1.410		865	0.13	9.2
6 5 0	2900	4.72	614.2	210	0.109	3.15	4.831	600.3	340	0.181	7.2	4.831	600.3	450	0.240	7.2	5.104	568.2	625	0.35	7.2	4.898	592.1	865	0.47	9.2
	1450	2.361		210	0.055	3.15	2.415		340	0.091	7.2	2.415		450	0.12	7.2	2.552		625	0.176	7.2	2.449		865	0.233	9.2
	960	1.563		210	0.036	3.15	1.599		340	0.06	7.2	1.599		450	0.079	7.2	1.689		625	0.116	7.2	1.621		865	0.155	9.2
	725	1.172		210	0.027	3.15	1.199		340	0.045	7.2	1.199		450	0.059	7.2	1.267		625	0.087	7.2	1.216		865	0.12	9.2
7 3 0	2900	3.94	736.9	210	0.091	3.15	4.024	720.7	340	0.151	7.2	4.024	720.7	450	0.200	7.2	4.253	681.9	625	0.29	7.2	4.080	710.8	865	0.39	9.2
	1450	1.968		210	0.046	3.15	2.012		340	0.075	7.2	2.012		450	0.1	7.2	2.126		625	0.146	7.2	2.040		865	0.194	9.2
	960	1.303		210	0.03	3.15	1.332		340	0.05	7.2	1.332		450	0.066	7.2	1.408		625	0.097	7.2	1.351		865	0.129	9.2
	725	0.977		210	0.023	3.15	0.999		340	0.037	7.2	0.999		450	0.050	7.2	1.056		625	0.073	7.2	1.013		865	0.097	9.2
8 6 0	2900	3.28	884.3	210	0.076	3.15	3.413	849.8	340	0.128	7.2	3.413	849.8	450	0.169	7.2	3.589	808.1	625	0.247	7.2	3.420	847.8	865	0.33	9.2
	1450	1.640		210	0.038	3.15	1.706		340	0.064	7.2	1.706		450	0.085	7.2	1.794		625	0.124	7.2	1.710		865	0.163	9.2
	960	1.086		210	0.025	3.15	1.13		340	0.042	7.2	1.130		450	0.056	7.2	1.188		625	0.082	7.2	1.132		865	0.108	9.2
	725	0.814		210	0.019	3.15	0.847		340	0.032	7.2	0.847		450	0.042	7.2	0.891		625	0.061	7.2	0.849		865	0.081	9.2
1 0 C	2900	2.81	1031	210	0.065	3.15	2.844	1020	340	0.107	7.2	2.844	1020	450	0.141	7.2	2.983	972.2	625	0.205	7.2	2.850	1017	865	0.27	9.2
	1450	1.407		210	0.033	3.15	1.422		340	0.053	7.2	1.422		450	0.071	7.2	1.491		625	0.103	7.2	1.425		865	0.136	9.2
	960	0.931		210	0.022	3.15	0.941		340	0.035	7.2	0.941		450	0.047	7.2	0.987		625	0.068	7.2	0.944		865	0.09	9.2
	725	0.698		210	0.016	3.15	0.706		340	0.026	7.2	0.706		450	0.035	7.2	0.741		625	0.051	7.2	0.708		865	0.067	9.2
1 1 C	2900	2.50	1161	210	0.058	3.15	2.597	1117	340	0.097	7.2	2.597	1117	450	0.129	7.2	2.566	1130	625	0.177	7.2	2.603	1114	865	0.248	9.2
	1450	1.248		210	0.029	3.15	1.299		340	0.049	7.2	1.299		450	0.064	7.2	1.283		625	0.088	7.2	1.301		865		

SERIES M

QUADRUPLE REDUCTION RATINGS

SIZES M08 - M14

*P*m - Input Power (kW) fra - Overhung Load (kN)
*M*2 - Output Torque (Nm)
i - Exact Ratio (:1)
*N*2 - Output Speed (rpm)

QUADRUPLE REDUCTION

Column Entry	Input Speed N1 (rpm)	M0842					M0941					M1041					M1341					M1441					
		N2 (rpm)	<i>i</i> (:1)	M2 (Nm)	<i>P</i> m (kW)	fra (kN)	N2 (rpm)	<i>i</i> (:1)	M2 (Nm)	<i>P</i> m (kW)	fra (kN)	N2 (rpm)	<i>i</i> (:1)	M2 (Nm)	<i>P</i> m (kW)	fra (kN)	N2 (rpm)	<i>i</i> (:1)	M2 (Nm)	<i>P</i> m (kW)	fra (kN)	N2 (rpm)	<i>i</i> (:1)	M2 (Nm)	<i>P</i> m (kW)	fra (kN)	
2 2 5	2900	12.67																									
	1450	6.334	228.9	1400	1.955	16.20	12.55	231.1	2640	3.65	28.0	13.16	220.3	4410	6.40	40.0	12.78	227	6350	8.94	64.0	11.75	246.9	10600	13.73	79.0	
	960	4.194		1400	0.647	16.20	4.154		2640	1.826	28.0	6.582		4410	3.199	40.0	6.388		6350	4.471	64.0	5.874		10600	6.863	79.0	
	725	3.145		1400	0.485	16.20	3.115		2640	1.209	28.0	4.358		4410	2.118	40.0	4.229		6350	2.96	64.0	3.889		10600	4.544	79.0	
2 5 0	2900	11.20																									
	1450	5.599	259	1500	1.85	16.20	11.23	258.2	2860	3.54	28.0	11.97	242.2	4410	5.82	40.0	11.62	249.6	6350	8.13	64.0	10.68	271.4	10600	12.48	79.0	
	960	3.707		1500	0.926	16.20	5.616		2860	1.77	28.0	5.986		4410	2.91	40.0	5.809		6350	4.066	64.0	5.342		10600	6.241	79.0	
	725	2.780		1500	0.613	16.20	3.718		2860	1.172	28.0	3.963		4410	1.926	40.0	3.846		6350	2.692	64.0	3.537		10600	4.132	79.0	
2 8 0	2900	9.63																									
	1450	4.814	301.2	1500	1.46	16.20	9.66	300.2	2860	0.879	28.0	2.972	278.3	4410	1.445	40.0	2.885	286.8	6350	2.019	64.0	2.653	311.9	10600	3.099	79.0	
	960	3.187		1500	0.59	16.20	2.789		2860	3.05	28.0	10.42		4410	5.46	40.0	10.11		6350	7.08	64.0	9.30		10600	10.86	79.0	
	725	2.390		1500	0.796	16.20	4.83		2860	1.523	28.0	5.209		4410	2.532	40.0	5.056		6350	3.539	64.0	4.649		10600	5.432	79.0	
3 0 0	2900	8.61																									
	1450	4.303	337	1500	1.42	16.20	8.64	335.8	2860	2.72	28.0	9.19	315.6	4410	4.47	40.0	8.92	325.2	6350	6.24	64.0	8.20	353.7	10600	9.58	79.0	
	960	2.849		1500	0.711	16.20	4.318		2860	1.361	28.0	4.594		4410	2.233	40.0	4.459		6350	3.121	64.0	4.1		10600	4.79	79.0	
	725	2.136		1500	0.395	16.20	2.398		2860	0.901	28.0	3.042		4410	1.479	40.0	2.952		6350	2.066	64.0	2.715		10600	3.172	79.0	
3 6 0	2900	8.07																									
	1450	4.037	359.2	1500	1.33	16.20	8.10	358.1	2860	0.676	28.0	2.281	348.2	4410	1.109	40.0	2.214	358.8	6350	1.55	64.0	2.036	390.2	10600	2.379	79.0	
	960	2.673		1500	0.442	16.20	2.681		2860	2.55	28.0	8.33		4410	4.05	40.0	8.08		6350	5.66	64.0	7.43		10600	8.68	79.0	
	725	2.005		1500	0.216	16.20	2.011		2860	1.277	28.0	4.164		4410	2.024	40.0	4.041		6350	2.829	64.0	3.716		10600	4.342	79.0	
4 0 0	2900	6.81																									
	1450	3.406	425.7	1500	1.13	16.20	6.83	424.4	2860	0.535	28.0	7.27	398.7	4410	3.54	40.0	7.06	410.8	6350	4.94	64.0	6.845	446.7	10600	7.58	79.0	
	960	2.255		1500	0.563	16.20	3.417		2860	1.077	28.0	3.637		4410	1.768	40.0	3.53		6350	2.47	64.0	3.246		10600	3.792	79.0	
	725	1.691		1500	0.373	16.20	2.262		2860	0.713	28.0	2.408		4410	1.17	40.0	2.337		6350	1.636	64.0	2.149		10600	2.511	79.0	
4 5 0	2900	6.04																									
	1450	3.018	480.5	1500	1.08	16.20	6.15	471.4	2860	0.713	28.0	1.806	443	4410	3.878	40.0	1.753	358.8	6350	1.227	64.0	1.612	492.3	10600	1.883	79.0	
	960	1.998		1500	0.28	16.20	1.697		2860	1.94	28.0	6.55		4410	1.18	40.0	8.08		6350	5.66	64.0	5.89		10800	7.01	79.0	
	725	1.498		1500	0.339	16.20	2.037		2860	0.97	28.0	3.273		4410	1.591	40.0	4.041		6350	2.829	64.0	2.945		10800	3.506	79.0	
5 0 0	2900	5.65																									
	1450	2.826	513	1540	0.512	16.20	3.076	503.1	2860	0.642	28.0	1.625	501.1	4410	1.053	40.0	2.676	523.8	6350	1.873	64.0	1.95	556.8	10800	2.321	79.0	
	960	1.871		1540	0.359	16.20	2.037		2860	1.82	28.0	5.79		4410	2.81	40.0	5.54		6350	3.87	64.0	5.21		10800	6.20	79.0	
	725	1.403		1540	0.48	16.20	2.882		2860	0.908	28.0	2.894		4410	1.407	40.0	2.768		6350	1.937	64.0	2.604		10800	3.1	79.0	
6 5 0	2900	4.66																									
	1450	2.331	621.9	1700	0.437	16.20	4.64	624.4	2860	0.451	28.0	1.437	580.9	4410	0.931	40.0	1.833	607.3	6350	1.283	64.0	1.724	645.5	10800	2.052	79.0	
	960	1.544		1700	0.238	16.20	1.431		2860	1.46	28.0	4.99		4410	0.698	40.0	1.374		6350	0.962	64.0	1.293		10800	1.539	79.0	
	725	1.158		1700	0.87	16.20	4.64		2860	0.364	28.0	1.239		4410	2.43	40.0	4.78		6350	3.34	64.0	4.49		10800	6.20	79.0	
7 3 0	2900	3.76																									
	1450	1.879	771.8	1700	0.217	16.20	1.153	736.2	2860	0.21	28.0	3.94	692.8	4410	2.03	40.0	4.00	724.3	6350	2.80	64.0	3.77	769.9	10800	4.48	79.0	
	960	1.244		1700	0.352	16.20	1.97		2860	1.62	28.0	2.093		4410	1.017	40.0	2.002		6350	1.401	64.0	1.883		10800	2.242	79.0	
	725	0.933		1700	0.233	16.20	1.304		2860	0.411	28.0	1.386		4410	0.674	40.0	1.325		6350	0.928	64.0	1.247		10800	1.484	79.0	
8 6 0	2900	3.22																									
	1450	1.611	900	1700	0.175	16.20	0.978	882.1	2860	0.308	28.0	1.039	828.4	4410	0.505	40.0	0.994	858.8	6350	0.696	64.0	0.935	929.4	10700	1.113	79.0	
	960	1.067		1700	1.04	16.20	3.29		2860	0.518	28.0	1.75		4410	1.70	40.0	3.38		6350	2.36	64.0	3.62		10700	4.27	79.0	
	725	0.8		1700	0.302	16.20	1.644		2860	0.343	28.0	1.159		4410	0.851	40.0	1.688		6350	1.182	64.0	1.809		10700	2.133	79.0	
1 0 C	2900	2.73																									
	1450	1.366	1061	1700	0.2	16.20	1.088	1040	2860	0.257	28.0	0.869	988	4410	0.563	40.0	1.118	1024	6350	0.782	64.0	1.198	929.4	10700	1.412	79.0	
	960	0.905		1700	0.15	16.20	0.816		2860	0.422	40.0	0.838		4410	0.422	40.0	0.838		6350	0.587	64.0	0.898		10700	1.059	79.0	
	725	0.678		1700	0.302	16.20	1.644		2860	0.88	28.0	2.94		4410	1.43	40.0	2.83		6350	1.98	64.0	3.12		10700	3.68	79.0	
1 1 C	2900	2.49																									
	1450	1.244	1166	1700	0.256	16.20	1.394	1148	2860	0.218	28.0	0.729	1138	4410	0.713	40.0	1.416	1141	6350	0.991	64.0	1.56	1108	10700	1.84	79.0	
	960	0.823		1700	0.169	16.20	0.923		2860	0.439	28.0	1.468		4410	0.472	40.0	0.937		6350	0.656	64.0	1.033		10700	1.218	79.0	
	725	0.618		1700	0.127	16.20	0.692		2860	0.218	28.0	0.729		4410	0.354	40.0	0.703		6350	0.492	64.0	0.775		10700	0.914	79.0	
1 3 C	2900	2.27																									
	1450	1.136	1277	1700	0.47	16.20	2.53	1340	2860	0.88	28.0	2.55	1246	4410	1.13	40.0	2.32	1249	6350	1.78	64.0	2.62	1214	10700	3.09	79.0	
	960	0.752		1700	0.233	16.20	1.263		2860	0.398	28.0	1.274		4410	0.619	40.0	1.271		6350	0.89	64.0	1.308		10700	1.543	79.0	
	725	0.564		1700	0.154	16.20	0.836																				

SERIES M

QUINTUPLE REDUCTION RATINGS

SIZES M03 - M07

Pm - Input Power (kW) *N2* - Output Speed (rpm)
M2 - Output Torque (Nm) *fra* - Overhung Load (kN)
i - Exact Ratio (:1)

QUINTUPLE REDUCTION

Column Entry	Input Speed N1 (rpm)	M0352					M0452					M0552					M0652					M0752				
		N2 (rpm)	<i>i</i> (:1)	M2 (Nm)	Pm (kW)	<i>fra</i> (kN)	N2 (rpm)	<i>i</i> (:1)	M2 (Nm)	Pm (kW)	<i>fra</i> (kN)	N2 (rpm)	<i>i</i> (:1)	M2 (Nm)	Pm (kW)	<i>fra</i> (kN)	N2 (rpm)	<i>i</i> (:1)	M2 (Nm)	Pm (kW)	<i>fra</i> (kN)	N2 (rpm)	<i>i</i> (:1)	M2 (Nm)	Pm (kW)	<i>fra</i> (kN)
2 7 C	2900	1.102	2632	210	0.026	3.15	1.092	2655	340	0.041	7.20	1.092	2655	450	0.054	7.20	1.095	2649	625	0.075	7.20	1.107	2619	865	0.106	9.20
	1450	0.551		210	0.013	3.15	0.546		340	0.021	7.20	0.546		450	0.027	7.20	0.547		625	0.038	7.20	0.554		865	0.053	9.20
	960	0.365		210	0.009	3.15	0.362		340	0.014	7.20	0.362		450	0.018	7.20	0.362		625	0.025	7.20	0.367		865	0.035	9.20
	725	0.274		210	0.006	3.15	0.271		340	0.010	7.20	0.271		450	0.014	7.20	0.272		625	0.019	7.20	0.275		865	0.026	9.20
3 2 C	2900	0.945	3068	210	0.022	3.15	0.937	3095	340	0.035	7.20	0.937	3095	450	0.046	7.20	0.939	3088	625	0.065	7.20	0.95	3053	865	0.046	9.20
	1450	0.473		210	0.011	3.15	0.468		340	0.018	7.20	0.468		450	0.023	7.20	0.47		625	0.033	7.20	0.475		865	0.046	9.20
	960	0.313		210	0.007	3.15	0.310		340	0.012	7.20	0.31		450	0.016	7.20	0.311		625	0.022	7.20	0.314		865	0.046	9.20
	725	0.235		210	0.005	3.15	0.233		340	0.009	7.20	0.233		450	0.012	7.20	0.233		625	0.016	7.20	0.236		865	0.046	9.20
3 6 C	2900	0.788	3681	210	0.018	3.15	0.795	3650	340	0.030	7.20	0.795	3650	450	0.039	7.20	0.757	3832	625	0.052	7.20	0.796	3641	865	0.076	9.20
	1450	0.394		210	0.009	3.15	0.397		340	0.015	7.20	0.397		450	0.02	7.20	0.378		625	0.026	7.20	0.398		865	0.038	9.20
	960	0.261		210	0.006	3.15	0.263		340	0.010	7.20	0.263		450	0.013	7.20	0.251		625	0.017	7.20	0.264		865	0.025	9.20
	725	0.196		210	0.005	3.15	0.197		340	0.007	7.20	0.197		450	0.01	7.20	0.188		625	0.013	7.20	0.198		865	0.019	9.20
4 0 C	2900	0.709	4091	210	0.016	3.15	0.715	4055	340	0.027	7.20	0.715	4055	450	0.035	7.20	0.681	4258	625	0.047	7.20	0.717	4046	865	0.068	9.20
	1450	0.354		210	0.008	3.15	0.358		340	0.014	7.20	0.358		450	0.018	7.20	0.341		625	0.024	7.20	0.358		865	0.035	9.20
	960	0.235		210	0.005	3.15	0.237		340	0.009	7.20	0.237		450	0.012	7.20	0.225		625	0.016	7.20	0.237		865	0.023	9.20
	725	0.176		210	0.004	3.15	0.178		340	0.007	7.20	0.178		450	0.009	7.20	0.169		625	0.012	7.20	0.178		865	0.017	9.20
4 6 C	2900	0.629	4609	210	0.015	3.15	0.653	4440	340	0.024	7.20	0.653	4440	450	0.032	7.20	0.578	5021	625	0.04	7.20	0.655	4431	865	0.062	9.20
	1450	0.315		210	0.007	3.15	0.327		340	0.012	7.20	0.327		450	0.016	7.20	0.289		625	0.02	7.20	0.327		865	0.032	9.20
	960	0.208		210	0.005	3.15	0.216		340	0.008	7.20	0.216		450	0.011	7.20	0.191		625	0.013	7.20	0.217		865	0.021	9.20
	725	0.156		210	0.004	3.15	0.162		340	0.006	7.20	0.162		450	0.008	7.20	0.143		625	0.01	7.20	0.163		865	0.016	9.20
5 5 C	2900	0.522	5550	210	0.012	3.15	0.542	5347	340	0.020	7.20	0.542	5347	450	0.027	7.20	0.48	6046	625	0.033	7.20	0.544	5335	865	0.052	9.20
	1450	0.261		210	0.006	3.15	0.271		340	0.010	7.20	0.271		450	0.014	7.20	0.24		625	0.017	7.20	0.272		865	0.026	9.20
	960	0.173		210	0.004	3.15	0.180		340	0.007	7.20	0.18		450	0.009	7.20	0.159		625	0.011	7.20	0.18		865	0.017	9.20
	725	0.13		210	0.003	3.15	0.135		340	0.005	7.20	0.135		450	0.007	7.20	0.119		625	0.008	7.20	0.135		865	0.013	9.20
6 5 C	2900	0.449	6452	203	0.01	3.15	0.443	6553	340	0.017	7.20	0.443	6553	450	0.022	7.20	0.438	6620	625	0.03	7.20	0.453	6403	865	0.043	9.20
	1450	0.225		203	0.005	3.15	0.221		340	0.008	7.20	0.221		450	0.011	7.20	0.219		625	0.015	7.20	0.226		865	0.022	9.20
	960	0.149		203	0.003	3.15	0.146		340	0.006	7.20	0.146		450	0.007	7.20	0.145		625	0.01	7.20	0.15		865	0.014	9.20
	725	0.112		203	0.003	3.15	0.110		340	0.004	7.20	0.11		450	0.006	7.20	0.109		625	0.008	7.20	0.112		865	0.011	9.20
7 4 C	2900	0.392	7396	203	0.009	3.15	0.386	7511	340	0.014	7.20	0.386	7511	450	0.019	7.20	0.382	7588	625	0.026	7.20	0.395	7339	865	0.038	9.20
	1450	0.196		203	0.004	3.15	0.193		340	0.007	7.20	0.193		450	0.01	7.20	0.191		625	0.013	7.20	0.198		865	0.019	9.20
	960	0.13		203	0.003	3.15	0.128		340	0.005	7.20	0.128		450	0.006	7.20	0.127		625	0.009	7.20	0.131		865	0.013	9.20
	725	0.097		203	0.002	3.15	0.096		340	0.004	7.20	0.096		450	0.005	7.20	0.095		625	0.007	7.20	0.098		865	0.009	9.20
8 4 C	2900	0.345	8394	203	0.008	3.15	0.346	8372	340	0.013	7.20	0.346	8372	380	0.015	7.20	0.336	8624	625	0.023	7.20	0.343	8443	725	0.027	9.20
	1450	0.173		203	0.004	3.15	0.173		340	0.007	7.20	0.173		380	0.007	7.20	0.168		625	0.012	7.20	0.172		725	0.014	9.20
	960	0.114		203	0.003	3.15	0.115		340	0.004	7.20	0.115		380	0.005	7.20	0.111		625	0.008	7.20	0.114		725	0.009	9.20
	725	0.086		203	0.002	3.15	0.086		340	0.003	7.20	0.086		380	0.004	7.20	0.083		625	0.006	7.20	0.085		725	0.007	9.20
9 5 C	2900	0.304	9540	203	0.007	3.15	0.305	9514	340	0.011	7.20	0.305	9514	380	0.013	7.20	0.312	9300	620	0.021	7.20	0.302	9596	725	0.024	9.20
	1450	0.152		203	0.003	3.15	0.152		340	0.006	7.20	0.152		380	0.006	7.20	0.156		620	0.011	7.20	0.151		725	0.012	9.20
	960	0.101		203	0.002	3.15	0.101		340	0.004	7.20	0.101		380	0.004	7.20	0.103		620	0.007	7.20	0.1		725	0.008	9.20
	725	0.075		203	0.002	3.15	0.076		340	0.003	7.20	0.076		380	0.003	7.20	0.077		620	0.005	7.20	0.075		725	0.006	9.20
1 0 K	2900	0.267	10845	203	0.006	3.15	0.272	10670	270	0.008	7.20	0.272	10670	270	0.008	7.20	0.274	10569	620	0.019	7.20	0.272	10662	725	0.022	9.20
	1450	0.134		203	0.003	3.15	0.136		270	0.004	7.20	0.136		270	0.004	7.20	0.137		620	0.009	7.20	0.136		725	0.011	9.20
	960	0.089		203	0.002	3.15	0.090		270	0.003	7.20	0.09		270	0.003	7.20	0.091		620	0.006	7.20	0.09		725	0.007	9.20
	725	0.066		203	0.002	3.15	0.067		270	0.002	7.20	0.067		270	0.002	7.20	0.068		620	0.005	7.20	0.068		725	0.005	9.20

SERIES M

QUINTUPLE REDUCTION RATINGS

SIZES M08 - M14

Pm - Input Power (kW) *fra* - Overhung Load (kN)
M2 - Output Torque (Nm)
i - Exact Ratio (:1)
N2 - Output Speed (rpm)

QUINTUPLE REDUCTION

Column Entry	Input Speed N1 (rpm)	M0852					M0951					M1051					M1351					M1451				
		N2 (rpm)	i (:1)	M2 (Nm)	Pm (kW)	fra (kN)	N2 (rpm)	i (:1)	M2 (Nm)	Pm (kW)	fra (kN)	N2 (rpm)	i (:1)	M2 (Nm)	Pm (kW)	fra (kN)	N2 (rpm)	i (:1)	M2 (Nm)	Pm (kW)	fra (kN)	N2 (rpm)	i (:1)	M2 (Nm)	Pm (kW)	fra (kN)
2 7 C	2900	1.063	2728	1700	0.199	16.20	1.116	2598	2860	0.352	28.0	1.186	2446	4410	0.576	40.0	1.144	2536	6350	0.801	64.0	1.057	2744	10700	1.246	79.0
	1450	0.531		1700	0.101	16.20	0.558		2860	0.178	28.0	0.593		4410	0.291	40.0	0.572		6350	0.405	64.0	0.528		10700	0.63	79.0
	960	0.352		1700	0.07	16.20	0.370		2860	0.12	28.0	0.393		4410	0.19	40.0	0.379		6350	0.27	64.0	0.350		10700	0.42	79.0
	725	0.264		1700	0.05	16.20	0.277		2860	0.088	28.0	0.294		4410	0.145	40.0	0.284		6350	0.201	64.0	0.262		10700	0.313	79.0
3 2 C	2900	0.886	3274	1700	0.166	16.20	0.93	3119	2860	0.293	28.0	0.956	3035	4410	0.464	40.0	0.922	3146	6350	0.645	64.0	0.852	3405	10700	1.005	79.0
	1450	0.443		1700	0.084	16.20	0.465		2860	0.148	28.0	0.478		4410	0.235	40.0	0.461		6350	0.326	64.0	0.426		10700	0.508	79.0
	960	0.293		1700	0.056	16.20	0.308		2860	0.10	28.0	0.316		4410	0.16	40.0	0.305		6350	0.22	64.0	0.282		10700	0.34	79.0
	725	0.22		1700	0.042	16.20	0.231		2860	0.074	28.0	0.237		4410	0.117	40.0	0.229		6350	0.162	64.0	0.211		10700	0.252	79.0
3 6 C	2900	0.76	3818	1700	0.142	16.20	0.775	3742	2860	0.244	28.0	0.81	3579	4410	0.394	40.0	0.782	3710	6350	0.547	64.0	0.722	4015	10700	0.852	79.0
	1450	0.38		1700	0.072	16.20	0.387		2860	0.123	28.0	0.405		4410	0.199	40.0	0.391		6350	0.276	64.0	0.361		10700	0.43	79.0
	960	0.251		1700	0.048	16.20	0.257		2860	0.082	28.0	0.268		4410	0.13	40.0	0.259		6350	0.18	64.0	0.239		10700	0.29	79.0
	725	0.189		1700	0.036	16.20	0.192		2860	0.061	28.0	0.201		4410	0.099	40.0	0.194		6350	0.137	64.0	0.179		10700	0.214	79.0
4 0 C	2900	0.674	4302	1700	0.126	16.20	0.688	4216	2860	0.217	28.0	0.74	3919	4410	0.36	40.0	0.714	4062	6350	0.5	64.0	0.66	4396	10700	0.778	79.0
	1450	0.337		1700	0.064	16.20	0.344		2860	0.11	28.0	0.37		4410	0.182	40.0	0.357		6350	0.252	64.0	0.33		10700	0.393	79.0
	960	0.223		1700	0.042	16.20	0.228		2860	0.073	28.0	0.245		4410	0.12	40.0	0.236		6350	0.17	64.0	0.218		10700	0.26	79.0
	725	0.167		1700	0.032	16.20	0.171		2860	0.054	28.0	0.184		4410	0.09	40.0	0.177		6350	0.125	64.0	0.164		10700	0.195	79.0
4 6 C	2900	0.614	4726	1700	0.115	16.20	0.623	4655	2860	0.196	28.0	0.642	4515	4410	0.312	40.0	0.641	4525	6350	0.449	64.0	0.584	4969	10100	0.65	79.0
	1450	0.307		1700	0.058	16.20	0.311		2860	0.099	28.0	0.321		4410	0.158	40.0	0.32		6350	0.227	64.0	0.292		10100	0.328	79.0
	960	0.203		1700	0.038	16.20	0.206		2860	0.066	28.0	0.213		4410	0.10	40.0	0.212		6350	0.15	64.0	0.193		10100	0.22	79.0
	725	0.152		1700	0.029	16.20	0.155		2860	0.049	28.0	0.159		4410	0.078	40.0	0.159		6350	0.113	64.0	0.145		10100	0.163	79.0
5 5 C	2900	0.528	5494	1700	0.099	16.20	0.536	5411	2860	0.169	28.0	0.524	5533	4410	0.255	40.0	0.523	5545	6350	0.366	64.0	0.533	5441	10100	0.593	79.0
	1450	0.264		1700	0.05	16.20	0.268		2860	0.085	28.0	0.262		4410	0.129	40.0	0.261		6350	0.185	64.0	0.267		10100	0.3	79.0
	960	0.175		1700	0.033	16.20	0.177		2860	0.057	28.0	0.174		4410	0.085	40.0	0.173		6350	0.12	64.0	0.176		10100	0.20	79.0
	725	0.131		1700	0.025	16.20	0.133		2860	0.042	28.0	0.13		4410	0.064	40.0	0.13		6350	0.092	64.0	0.132		10100	0.149	79.0
6 5 C	2900	0.431	6733	1700	0.081	16.20	0.43	6742	2480	0.118	28.0	0.475	6106	4260	0.223	40.0	0.428	6783	6350	0.299	64.0	0.435	6668	10100	0.484	79.0
	1450	0.215		1700	0.041	16.20	0.215		2480	0.059	28.0	0.237		4260	0.113	40.0	0.214		6350	0.151	64.0	0.217		10100	0.245	79.0
	960	0.143		1700	0.027	16.20	0.142		2480	0.039	28.0	0.157		4260	0.075	40.0	0.142		6350	0.10	64.0	0.144		10100	0.16	79.0
	725	0.107		1700	0.02	16.20	0.107		2480	0.03	28.0	0.118		4260	0.056	40.0	0.106		6350	0.075	64.0	0.108		10100	0.121	79.0
7 4 C	2900	0.38	7641	1700	0.071	16.20	0.379	7652	2480	0.104	28.0	0.388	7483	4260	0.182	40.0	0.384	7561	6350	0.268	64.0	0.39	7432	10100	0.434	79.0
	1450	0.19		1700	0.036	16.20	0.189		2480	0.052	28.0	0.194		4260	0.092	40.0	0.192		6350	0.136	64.0	0.195		10100	0.22	79.0
	960	0.126		1700	0.024	16.20	0.125		2480	0.035	28.0	0.128		4260	0.061	40.0	0.127		6350	0.090	64.0	0.129		10100	0.15	79.0
	725	0.094		1700	0.018	16.20	0.094		2480	0.026	28.0	0.096		4260	0.046	40.0	0.095		6350	0.067	64.0	0.097		10100	0.109	79.0
8 4 C	2900	0.348	8344	1700	0.065	16.20	0.343	8449	2860	0.108	28.0	0.348	8340	4260	0.163	40.0	0.342	8479	6350	0.239	64.0	0.348	8335	10100	0.387	79.0
	1450	0.174		1700	0.033	16.20	0.172		2860	0.055	28.0	0.174		4260	0.083	40.0	0.171		6350	0.121	64.0	0.174		10100	0.196	79.0
	960	0.115		1700	0.022	16.20	0.114		2860	0.036	28.0	0.115		4260	0.055	40.0	0.113		6350	0.080	64.0	0.115		10100	0.13	79.0
	725	0.086		1700	0.016	16.20	0.085		2860	0.027	28.0	0.086		4260	0.041	40.0	0.085		6350	0.06	64.0	0.086		10100	0.097	79.0
9 5 C	2900	0.306	9486	1700	0.057	16.20	0.302	9605	2860	0.095	28.0	0.31	9354	4260	0.146	40.0	0.306	9490	5700	0.192	64.0	0.285	10192	9280	0.291	79.0
	1450	0.153		1700	0.029	16.20	0.151		2860	0.048	28.0	0.155		4260	0.074	40.0	0.153		5700	0.097	64.0	0.142		9280	0.147	79.0
	960	0.101		1700	0.019	16.20	0.100		2860	0.032	28.0	0.103		4260	0.049	40.0	0.101		5700	0.064	64.0	0.094		9280	0.10	79.0
	725	0.076		1700	0.014	16.20	0.075		2860	0.024	28.0	0.077		4260	0.037	40.0	0.076		5700	0.048	64.0	0.071		9280	0.073	79.0
1 0 K	2900	0.265	10924	1550	0.045	16.20	0.242	11966	2480	0.066	28.0	0.289	10048	4230	0.135	40.0	0.287	10097	6030	0.191	64.0	0.254	11430	9280	0.26	79.0
	1450	0.133		1550	0.023	16.20	0.121		2480	0.033	28.0	0.144		4230	0.068	40.0	0.144		6030	0.096	64.0	0.127		9280	0.131	79.0
	960	0.088		1550	0.015	16.20	0.080		2480	0.022	28.0	0.096		4230	0.045	40.0	0.095		6030	0.064	64.0	0.084		9280	0.087	79.0
	725	0.066		1550	0.011	16.20	0.06		2480	0.017	28.0	0.072		4230	0.034	40.0	0.071		6030	0.048	64.0	0.063		9280	0.065	79.0

SERIES M

DIMENSIONS - DOUBLE REDUCTION BASE MOUNT

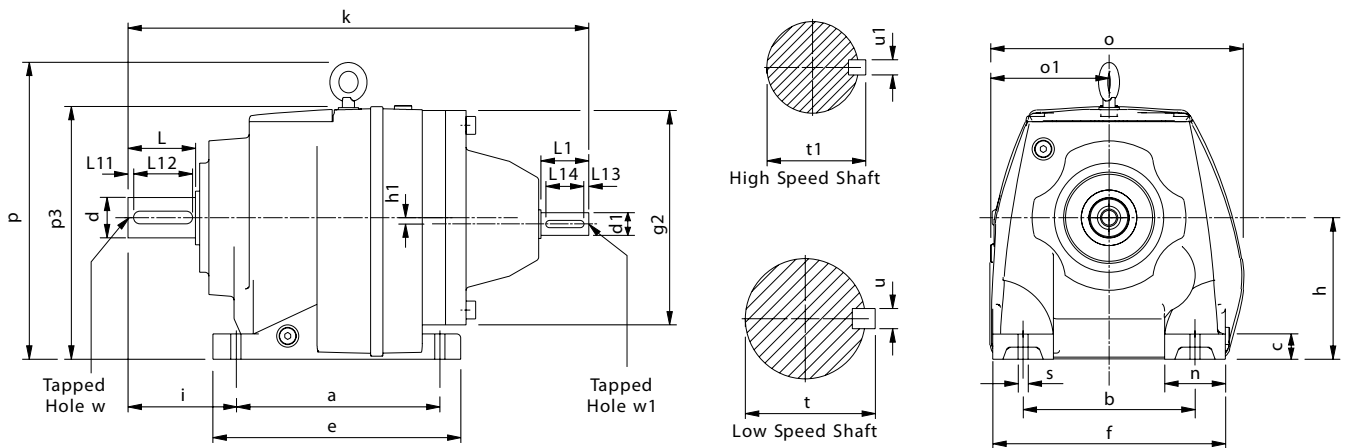

size	a	b	c	e	f	g2	h	h1	i	k	n	o	o1	p	p3	s
M0122	110	110	12	131	135	140	75	-	58	286	25	152	76	-	149	10
M0222	130	110	16	152	145	140	90	-	75	317	35	170	84	-	180	10
M0322	130	110	16	152	145	140	90	-	75	317	35	170	84	-	180	10
M0422	165	135	20	200	190	180	115	-	90	369	55	204	97	-	208	15
M0522	165	135	20	200	190	180	115	-	100	379	55	204	97	-	208	15
M0622	195	150	24	235	210	180	130	14.5	100	400	60	220	110	246	214	15
M0722	205	170	25	245	230	212	140	-	115	440	60	252	119	295	250	19
M0822	260	215	35	310	290	250	180	-	140	555	75	320	167	360	310	19
M0921	310	250	40	365	340	300	225	-	160	660	90	372	200	433	394	23
M1021	370	290	45	440	400	360	250	-	185	782	110	428	225	505	446	27
M1321	410	340	50	490	450	400	265	-	220	907	110	470	242	563	483	34
M1421	500	380	50	590	530	460	300	-	260	1022	150	546	278	630	551	41

SIZE	High Speed shaft							Low Speed shaft						
	d1	L1	L13	L14	t1	u1	w1	d	L	L11	L12	t	u	w
M0122	16	40	4	32	18	5	M5 x 0.8 12 deep	20 k6	40	4	32	22.5	6	M6 x 1 16 deep
M0222	16	40	4	32	18	5	M5 x 0.8 12 deep	25 k6	50	4	40	28	8	M10 x 1.5 22 deep
M0322	16	40	4	32	18	5	M5 x 0.8 12 deep	25 k6	50	4	40	28	8	M10 x 1.5 22 deep
M0422	19	40	4	32	21.5	6	M6 x 1.0 16 deep	30 k6	60	4	50	33	8	M10 x 1.5 22 deep
M0522	19	40	4	32	21.5	6	M6 x 1.0 16 deep	35 k6	70	7	60	38	10	M12 x .75 28 deep
M0622	19	40	4	32	21.5	6	M6 x 1.0 16 deep	35 k6	70	7	60	38	10	M12 x 1.75 28 deep
M0722	24	50	5	40	27	8	M8 x 1.25 19 deep	40 k6	80	5	70	43	12	M16 x 2.0 36 deep
M0822	28	60	5	50	31	8	M10 x 1.5 22 deep	50 k6	100	10	80	53.5	14	M16 x 2.0 36 deep
M0921	38	80	5	70	41	10	M12 x 1.75 28 deep	60 m6	120	10	100	64	18	M20 x 2.5 42 deep
M1021	42	110	10	70	45	12	M16 x 2.0 36 deep	70 m6	140	15	110	74.5	20	M20 x 2.5 42 deep
M1321	55	110	10	90	59	16	M20 x 2.5 42 deep	90 m6	170	15	140	95	25	M24 x 3.0 50 deep
M1421	55	110	10	90	59	16	M20 x 2.5 42 deep	100 m6	210	15	180	106	28	M24 x 3.0 50 deep

all parallel keys are to DIN 6885

SERIES M

DIMENSIONS - TRIPLE REDUCTION BASE MOUNT

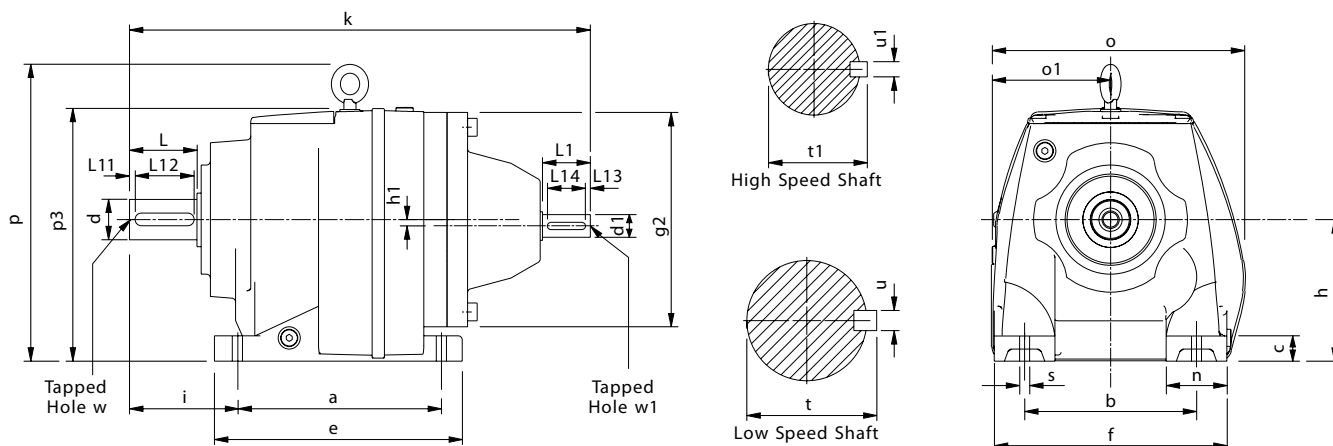

size	a	b	c	e	f	g2	h	h1	i	k	n	o	o1	p	p3	s
M0132	110	110	12	131	135	140	75	-	58	301	25	152	76	-	149	10
M0232	130	110	16	152	145	140	90	-	75	330	35	170	84	-	180	10
M0332	130	110	16	152	145	140	90	-	75	330	35	170	84	-	180	10
M0432	165	135	20	200	190	180	115	-	90	377	55	204	97	-	208	15
M0532	165	135	20	200	190	180	115	-	100	387	55	204	97	-	208	15
M0632	195	150	24	235	210	180	130	14.5	100	408	60	220	110	246	214	15
M0732	205	170	25	245	230	212	140	-	115	452	60	252	119	295	250	19
M0832	260	215	35	310	290	250	180	-	140	540	75	320	167	360	310	19
M0931	310	250	40	365	340	250	225	-	160	662	90	372	200	433	394	23
M1031	370	290	45	440	400	300	250	-	185	784	110	428	225	505	446	27
M1331	410	340	50	490	450	400	265	-	220	969	110	470	242	563	483	34
M1431	500	380	50	590	530	460	300	-	260	1094	150	546	278	630	551	41

SIZE	High Speed shaft							Low Speed shaft						
	d1	L1	L13	L14	t1	u1	w1	d	L	L11	L12	t	u	w
M0132	16 k6	40	4	32	18	5	M5 x 0.8 12 deep	20	40	4	32	22.5	6	M6 x 1.16 deep
M0232	16 k6	40	4	32	18	5	M5 x 0.8 12 deep	25	50	4	40	28	8	M10 x 1.5 22 deep
M0332	16 k6	40	4	32	18	5	M5 x 0.8 12 deep	25	50	4	40	28	8	M10 x 1.5 22 deep
M0432	16 k6	40	4	32	18	5	M5 x 0.8 12 deep	30	60	4	50	33	8	M10 x 1.5 22 deep
M0532	16 k6	40	4	32	18	5	M5 x 0.8 12 deep	35	70	7	60	38	10	M12 x 1.75 28 deep
M0632	16 k6	40	4	32	18	5	M5 x 0.8 12 deep	35	70	7	60	38	10	M12 x 1.75 28 deep
M0732	19 k6	40	4	32	21.5	6	M6 x 1.0 16 deep	40	80	5	70	43	12	M16 x 2.0 36 deep
M0832	24 k6	50	5	40	27	8	M8 x 1.25 19 deep	50	100	10	80	53.5	14	M16 x 2.0 36 deep
M0931	28 k6	60	5	50	31	8	M10 x 1.5 22 deep	60	120	10	100	64	18	M20 x 2.5 42 deep
M1031	38 k6	80	5	70	41	10	M12 x 1.75 28 deep	70	140	15	110	74.5	20	M20 x 2.5 42 deep
M1331	55 m6	110	10	90	59	16	M20 x 2.5 42 deep	90	170	15	140	95	25	M24 x 3.0 50 deep
M1431	55 m6	110	10	90	59	16	M20 x 2.5 42 deep	100	210	15	180	106	28	M24 x 3.0 50 deep

all parallel keys are to DIN 6885

SERIES M

DIMENSIONS - QUADRUPLE REDUCTION BASE MOUNT

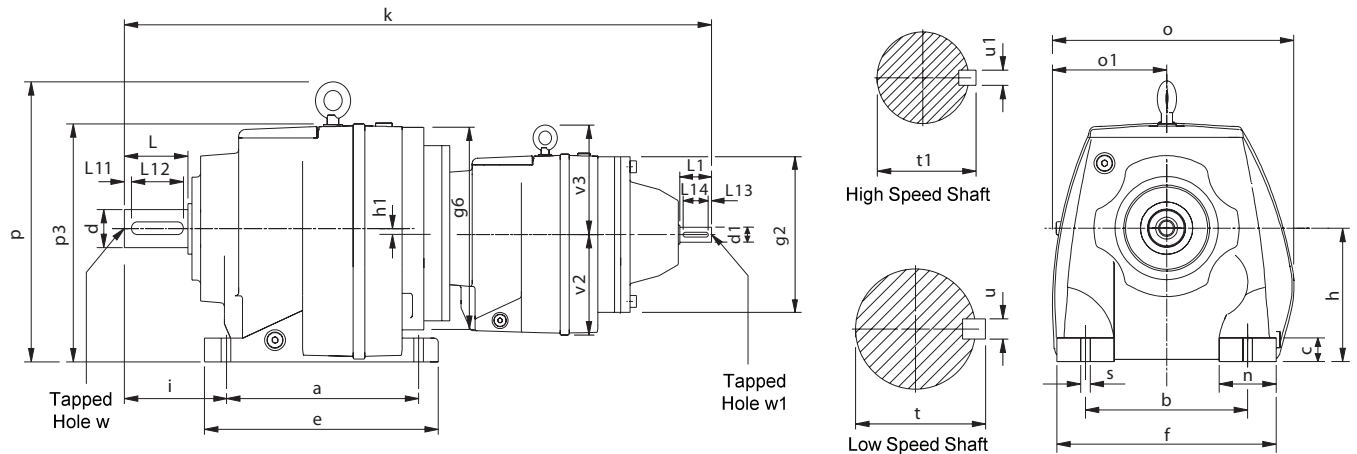

size	a	b	c	e	f	g2	g6	h	h1	i	k	n	o	o1	p	p3	s	v2	v3
M0342	130	110	16	152	145	140	140	90	-	75	503	35	170	84	-	180	10	76	-
M0442	165	135	20	200	190	140	180	115	-	90	571	55	204	97	-	208	15	91	-
M0542	165	135	20	200	190	140	180	115	-	100	581	55	204	97	-	208	15	91	-
M0642	195	150	24	235	210	140	180	130	14.5	100	602	60	220	110	246	214	15	91	-
M0742	205	170	25	245	230	140	212	140	-	115	639	60	252	119	295	250	19	91	-
M0842	260	215	35	310	290	180	250	180	-	140	751	75	320	167	360	310	19	115	-
M0941	310	250	40	365	340	180	250	225	-	160	832	90	372	200	433	394	23	113	-
M1041	370	290	45	440	400	180	300	250	-	185	956	110	428	225	505	446	27	138	155
M1341	410	340	50	490	450	212	350	265	-	220	1077	110	470	242	563	483	34	187	155
M1441	500	380	50	590	530	212	350	300	-	260	1192	150	546	278	630	551	41	187	155

SIZE	High Speed shaft							Low Speed shaft						
	d1	L1	L13	L14	t1	u1	w1	d	L	L11	L12	t	u	w
M0342	16 k6	40	4	32	18	5	M5 x 0.8 12 deep	25 k6	50	4	40	28	8	M10 x 1.5 22 deep
M0442	16 k6	40	4	32	18	5	M5 x 0.8 12 deep	30 k6	60	4	50	33	8	M10 x 1.5 22 deep
M0542	16 k6	40	4	32	18	5	M5 x 0.8 12 deep	35 k6	70	7	60	38	10	M12 x 1.75 28 deep
M0642	16 k6	40	4	32	18	5	M5 x 0.8 12 deep	35 k6	70	7	60	38	10	M12 x 1.75 28 deep
M0742	16 k6	40	4	32	18	5	M5 x 0.8 12 deep	40 k6	80	5	70	43	12	M16 x 2.0 36 deep
M0842	19 k6	40	4	32	21.5	6	M6 x 1.0 16 deep	50 k6	100	10	80	53.5	14	M16 x 2.0 36 deep
M0941	19 k6	40	4	32	21.5	6	M6 x 1.0 16 deep	60 m6	120	10	100	64	18	M20 x 2.5 42 deep
M1041	24 k6	50	5	40	27	8	M8 x 1.25 19 deep	70 m6	140	15	110	74.5	20	M20 x 2.5 42 deep
M1341	24 k6	50	5	40	27	8	M8 x 1.25 19 deep	90 m6	170	15	140	95	25	M24 x 3.0 50 deep
M1441	24 k6	50	5	40	27	8	M8 x 1.25 19 deep	100 m6	210	15	180	106	28	M24 x 3.0 50 deep

SERIES M

DIMENSIONS - QUINTUPLE REDUCTION BASE MOUNT

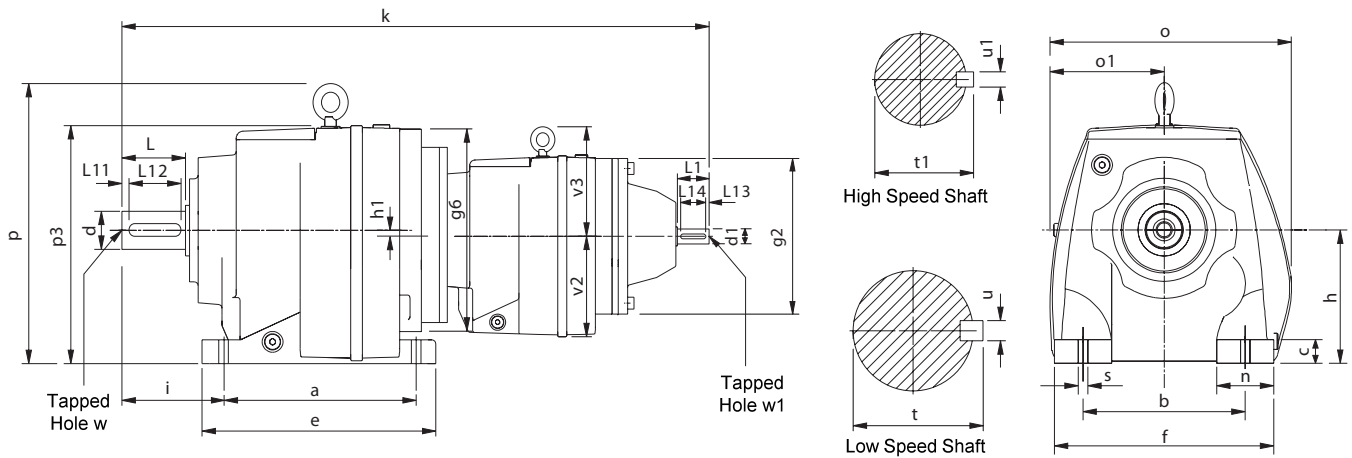

size	a	b	c	e	f	g2	g6	h	h1	i	k	n	o	o1	p	p3	s	v2	v3
M0352	130	110	16	152	145	140	140	90	-	75	518	35	170	84	-	180	10	76	-
M0452	165	135	20	200	190	140	180	115	-	90	584	55	204	97	-	208	15	91	-
M0552	165	135	20	200	190	140	180	115	-	100	594	55	204	97	-	208	15	91	-
M0652	195	150	24	235	210	140	180	130	14.5	100	615	60	220	110	246	214	15	91	-
M0752	205	170	25	245	230	140	212	140	-	115	651	60	252	119	295	250	19	91	-
M0852	260	215	35	310	290	180	250	180	-	140	759	75	320	167	360	310	19	115	-
M0951	310	250	40	365	340	180	250	225	-	160	840	90	372	200	433	394	23	113	-
M1051	370	290	45	440	400	180	300	250	-	185	968	110	428	225	505	446	27	138	155
M1351	410	340	50	490	450	212	350	265	-	220	1089	110	470	242	563	483	34	187	155
M1451	500	380	50	590	530	212	350	300	-	260	1204	150	546	278	630	551	41	187	155

SIZE	High Speed shaft							Low Speed shaft						
	d1	L1	L13	L14	t1	u1	w1	d	L	L11	L12	t	u	w
M0352	16 k6	40	4	32	18	5	M5 x 0.8 12 deep	25 k6	50	4	40	28	8	M10 x 1.5 22 deep
M0452	16 k6	40	4	32	18	5	M5 x 0.8 12 deep	30 k6	60	4	50	33	8	M10 x 1.5 22 deep
M0552	16 k6	40	4	32	18	5	M5 x 0.8 12 deep	35 k6	70	7	60	38	10	M12 x 1.75 28 deep
M0652	16 k6	40	4	32	18	5	M5 x 0.8 12 deep	35 k6	70	7	60	38	10	M12 x 1.75 28 deep
M0752	16 k6	40	4	32	18	5	M5 x 0.8 12 deep	40 k6	80	5	70	43	12	M16 x 2.0 36 deep
M0852	16 k6	40	4	32	18	5	M5 x 0.8 12 deep	50 k6	100	10	80	53.5	14	M16 x 2.0 36 deep
M0951	16 k6	40	4	32	18	5	M5 x 0.8 12 deep	60 m6	120	10	100	64	18	M20 x 2.5 42 deep
M1051	19 k6	40	4	32	21.5	6	M6 x 1.0 16 deep	70 m6	140	15	110	74.5	20	M20 x 2.5 42 deep
M1351	19 k6	40	4	32	21.5	6	M6 x 1.0 16 deep	90 m6	170	15	140	95	25	M24 x 3.0 50 deep
M1451	19 k6	40	4	32	21.5	6	M6 x 1.0 16 deep	100 m6	210	15	180	106	28	M24 x 3.0 50 deep

SERIES M

DIMENSIONS - DOUBLE REDUCTION FLANGE MOUNT

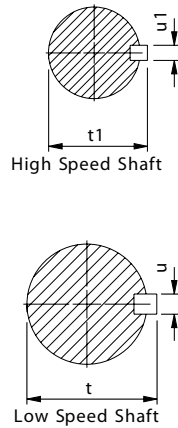
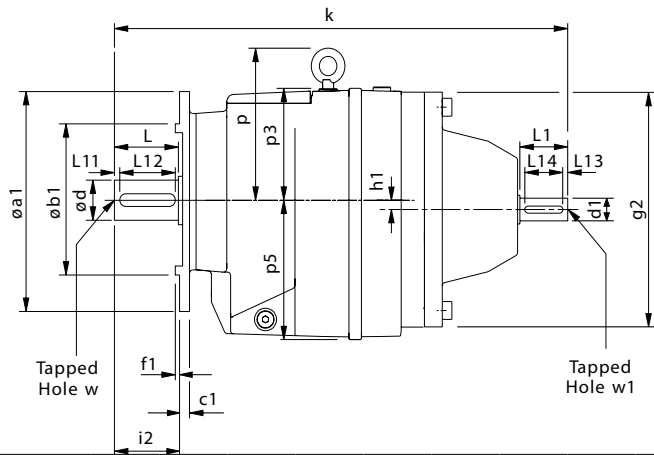

Sizes 1, 2, 3, 4, 5, 6, 7 and 8

Sizes 9, 10, 13 and 14

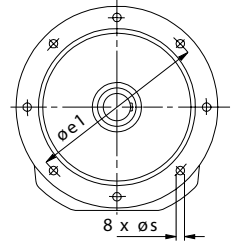
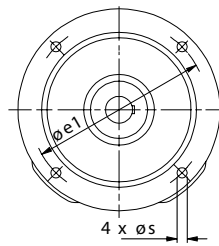

Note: Sizes 01 to 08 are also available as C-Flange (B14) Mounting, please see page 118 for details

Size	Øa1	Øb1	c1	Øe1	f1	Øg2	h1	i2	k	p	p3	p5	s
M0122	120	80	9	100	3	140	-	40	286	-	74	76	7
	140	95	9	115	3			40					9
	160	110	10	130	3.5			40					9
	200	130	10	165	3.5			40					11
M0222	120	80	10	100	3	140	-	50	317	-	90	91	6.6
	140	95	10	115	3			50					9
	160	110	10	130	3.5			50					9
	200	130	10	165	3.5			50					11
M0322	120	80	10	100	3	140	-	50	317	-	90	91	6.6
	140	95	10	115	3			50					9
	160	110	10	130	3.5			50					9
	200	130	10	165	3.5			50					11
M0422	140	95	11	115	3	180	-	60	369	-	93	115	9
	160	110	11	130	3.5			60					9
	200	130	11	165	3.5			60					11
	250	180	11	215	4			60					13.5
M0522	140	95	11	115	3	180	-	70	379	-	93	115	9
	160	110	11	130	3.5			70					9
	200	130	11	165	3.5			70					11
	250	180	11	215	4			70					13.5
M0622	200	130	11	165	4	180	14.5	70	400	116	84	130	11
	250	180	11	215	4			70					13.5
	300	230	11	265	4			70					13.5
M0722	200	130	11	165	3.5	212	-	80	440	155	110	140	11
	250	180	11	215	4			80					13.5
	300	230	11	265	4			80					13.5
M0822	300	230	17	265	4	250	-	100	55	180	130	182	13.5
	350	250	17	300	5			100					17.5
M0921	450	350	18	400	5	300	-	140	660	198	-	230	18
M1021	450	350	22	400	5	360	-	140	782	245	-	260	18
M1321	550	450	25	500	5	400	-	170	907	288	-	278	18
M1421	550	450	25	500	5	460	-	210	1022	320	-	318	18

SIZE	High Speed shaft							Low Speed shaft						
	d1	L1	L13	L14	t1	u1	w1	d	L	L11	L12	t	u	w1
M0122	16 k6	40	4	32	18	5	M5 x 0.8 12 deep	20 k6	40	4	32	22.5	6	M6 x 1.16 deep
M0222	16 k6	40	4	32	18	5	M5 x 0.8 12 deep	25 k6	50	4	40	28	8	M10 x 1.5 22 deep
M0322	16 k6	40	4	32	18	5	M5 x 0.8 12 deep	25 k6	50	4	40	28	8	M10 x 1.5 22 deep
M0422	19 k6	40	4	32	21.5	6	M6 x 1.0 16 deep	30 k6	60	4	50	33	8	M10 x 1.5 22 deep
M0522	19 k6	40	4	32	21.5	6	M6 x 1.0 16 deep	35 k6	70	7	60	38	10	M12 x 1.75 28 deep
M0622	19 k6	40	4	32	21.5	6	M6 x 1.0 16 deep	35 k6	70	7	60	38	10	M12 x 1.75 28 deep
M0722	24 k6	50	5	40	27	8	M8 x 1.25 19 deep	40 k6	80	5	70	43	12	M16 x 2.0 36 deep
M0822	28 k6	60	5	50	31	8	M10 x 1.5 22 deep	50 k6	100	10	80	53.5	14	M16 x 2.0 36 deep
M0921	38 k6	80	5	70	41	10	M12 x 1.75 28 deep	60 m6	120	10	100	64	18	M20 x 2.5 42 deep
M1021	42 k6	110	10	70	45	12	M16 x 2.0 36 deep	70 m6	140	15	110	74.5	20	M20 x 2.5 42 deep
M1321	55 m6	110	10	90	59	16	M20 x 2.5 42 deep	90 m6	170	15	140	95	25	M24 x 3.0 50 deep
M1421	55 m6	110	10	90	59	16	M20 x 2.5 42 deep	100 m6	210	15	180	106	28	M24 x 3.0 50 deep

all parallel keys are to DIN 6885

SERIES M

DIMENSIONS - TRIPLE REDUCTION FLANGE MOUNT

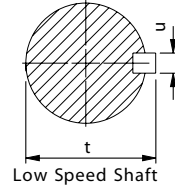
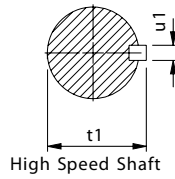
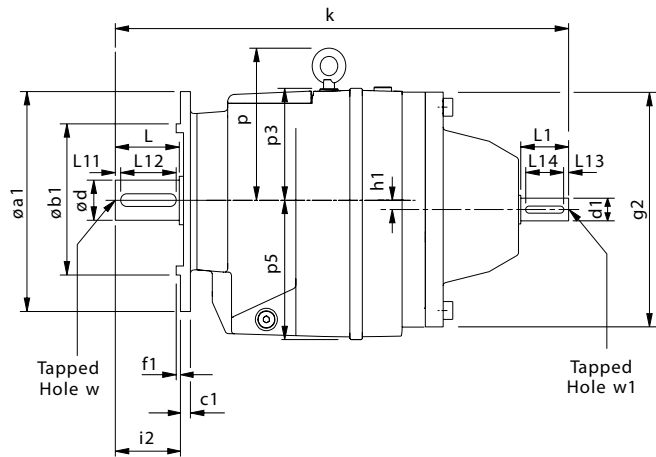

Sizes
1, 2, 3, 4, 5, 6, 7 and 8

Sizes
9, 10, 13 and 14

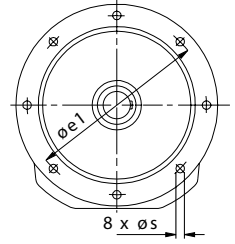
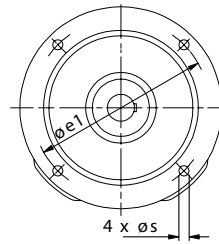

Note: Sizes 01 to 08 are also available as C-Flange (B14) Mounting, please see page 118 for details

Size	Øa1	Øb1	c1	Øe1	f1	Øg2	h1	i2	k	p	p3	p5	s
M0132	120	80	9	100	3	140	-	40	301	-	74	76	7
	140	95	9	115	3			40					9
	160	110	10	130	3.5			40					9
	200	130	10	165	3.5			40					11
M0232	120	80	10	100	3	140	-	50	330	-	90	91	6.6
	140	95	10	115	3			50					9
	160	110	10	130	3.5			50					9
	200	130	10	165	3.5			50					11
M0332	120	80	10	100	3	140	-	50	330	-	90	91	6.6
	140	95	10	115	3			50					9
	160	110	10	130	3.5			50					9
	200	130	10	165	3.5			50					11
M0432	140	95	11	115	3	180	-	60	377	-	93	115	9
	160	110	11	130	3.5			60					9
	200	130	11	165	3.5			60					11
	250	180	11	215	4			60					13.5
M0532	140	95	11	115	3	180	-	70	387	-	93	115	9
	160	110	11	130	3.5			70					9
	200	130	11	165	3.5			70					11
	250	180	11	215	4			70					13.5
M0632	200	130	11	165	4	180	14.5	70	408	116	84	130	11
	250	180	11	215	4			70					13.5
	300	230	11	265	4			70					13.5
M0732	200	130	11	165	3.5	212	-	80	452	155	110	140	11
	250	180	11	215	4			80					13.5
	300	230	11	265	4			80					13.5
M0832	300	230	17	265	4	250	-	100	540	180	130	182	13.5
	350	250	17	300	5			100					17.5
M0931	450	350	18	400	5	300	-	140	662	198	-	230	18
M1031	450	350	22	400	5	360	-	140	784	245	-	260	18
M1331	550	450	25	500	5	400	-	170	969	288	-	278	18
M1431	550	450	25	500	5	460	-	210	1094	320	-	318	18

Size	High Speed shaft							Low Speed shaft						
	d1	L1	L13	L14	t1	u1	w1	d	L	L11	L12	t	u	w1
M0122	16 k6	40	4	32	18	5	M5 x 0.8 12 deep	20 k6	40	4	32	22.5	6	M6 x 1 16 deep
M0222	16 k6	40	4	32	18	5	M5 x 0.8 12 deep	25 k6	50	4	40	28	8	M10 x 1.5 22 deep
M0322	16 k6	40	4	32	18	5	M5 x 0.8 12 deep	25 k6	50	4	40	28	8	M10 x 1.5 22 deep
M0422	19 k6	40	4	32	21.5	6	M6 x 1.0 16 deep	30 k6	60	4	50	33	8	M10 x 1.5 22 deep
M0522	19 k6	40	4	32	21.5	6	M6 x 1.0 16 deep	35 k6	70	7	60	38	10	M12 x 1.75 28 deep
M0622	19 k6	40	4	32	21.5	6	M6 x 1.0 16 deep	35 k6	70	7	60	38	10	M12 x 1.75 28 deep
M0722	24 k6	50	5	40	27	8	M8 x 1.25 19 deep	40 k6	80	5	70	43	12	M16 x 2.0 36 deep
M0822	28 k6	60	5	50	31	8	M10 x 1.5 22 deep	50 k6	100	10	80	53.5	14	M16 x 2.0 36 deep
M0921	38 k6	80	5	70	41	10	M12 x 1.75 28 deep	60 m6	120	10	100	64	18	M20 x 2.5 42 deep
M1021	42 k6	110	10	70	45	12	M16 x 2.0 36 deep	70 m6	140	15	110	74.5	20	M20 x 2.5 42 deep
M1321	55 m6	110	10	90	59	16	M20 x 2.5 42 deep	90 m6	170	15	140	95	25	M24 x 3.0 50 deep
M1421	55 m6	110	10	90	59	16	M20 x 2.5 42 deep	100 m6	210	15	180	106	28	M24 x 3.0 50 deep

all parallel keys are
to DIN 6885

SERIES M

DIMENSIONS - QUADRUPLE REDUCTION FLANGE MOUNT

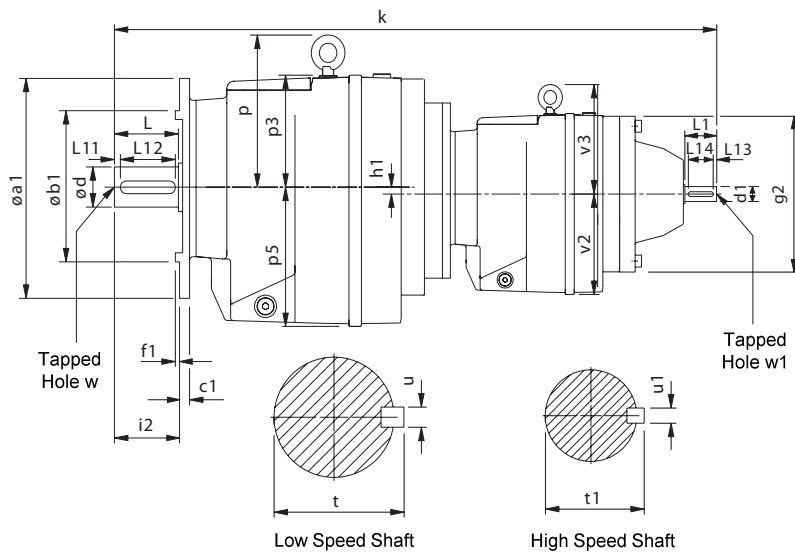

Sizes
3, 4, 5, 6, 7 and 8

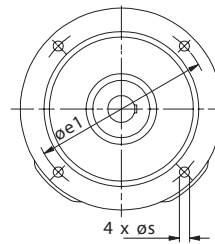

Sizes
9, 10, 13 and 14

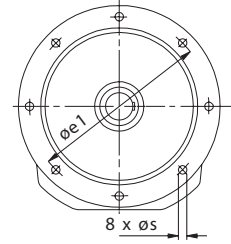

Note: Sizes 03 to 08 are also available as C-Flange (B14) Mounting, please see page 118 for details

Size	$\varnothing a1$	$\varnothing b1$	c1	$\varnothing e1$	f1	$\varnothing g2$	h1	i2	k	p	p3	p5	s	v2	v3
M0342	120	80	10	100	3	140	-	50	503	-	90	91	6.6	76	-
	140	95	10	115	3			50					9		
	160	110	10	130	3.5			50					9		
	200	130	10	165	3.5			50					11		
M0442	140	95	11	115	3	140	-	60	571	-	93	115	9	91	-
	160	110	11	130	3.5			60					9		
	200	130	11	165	3.5			60					11		
	250	180	11	215	4			60					13.5		
M0542	140	95	11	115	3	140	-	70	581	-	93	115	9	91	-
	160	110	11	130	3.5			70					9		
	200	130	11	165	3.5			70					11		
	250	180	11	215	4			70					13.5		
M0642	200	130	11	165	4	140	14.5	70	602	116	84	130	11	91	-
	250	180	11	215	4			70					13.5		
	300	230	11	265	4			70					13.5		
M0742	200	130	11	165	3.5	140	-	80	639	155	110	140	11	91	-
	250	180	11	215	4			80					13.5		
	300	230	11	265	4			80					13.5		
M0842	300	230	17	265	4	180	-	100	751	180	130	182	13.5	115	-
	350	250	17	300	5			100					17.5		
M0941	450	350	18	400	5	180	-	140	832	198	-	230	18	115	-
M1041	450	350	22	400	5	212	-	140	956	245	-	260	18	140	155
M1341	550	450	25	500	5	212	-	170	1077	288	-	278	18	140	155
M1441	550	450	25	500	5	212	-	210	1192	320	-	318	18	140	155

Size	High Speed shaft							Low Speed shaft						
	d1	L1	L13	L14	t1	u1	w1	d	L	L11	L12	t	u	w1
M0342	16 k6	40	4	32	18	5	M5 x 0.8 12 deep	25 k6	50	4	40	28	8	M10 x 1.5 22 deep
M0442	16 k6	40	4	32	18	5	M5 x 0.8 12 deep	30 k6	60	4	50	33	8	M10 x 1.5 22 deep
M0542	16 k6	40	4	32	18	5	M5 x 0.8 12 deep	35 k6	70	7	60	38	10	M12 x 1.75 28 deep
M0642	16 k6	40	4	32	18	5	M5 x 0.8 12 deep	35 k6	70	7	60	38	10	M12 x 1.75 28 deep
M0742	16 k6	40	4	32	18	5	M5 x 0.8 12 deep	40 k6	80	5	70	43	12	M16 x 2.0 36 deep
M0842	19 k6	40	4	32	21.5	6	M6 x 1.0 16 deep	50 k6	100	10	80	53.5	14	M16 x 2.0 36 deep
M0941	19 k6	40	4	32	21.5	6	M6 x 1.0 16 deep	60 m6	120	10	100	64	18	M20 x 2.5 42 deep
M1041	24 k6	50	5	40	27	8	M8 x 1.25 19 deep	70 m6	140	15	110	74.5	20	M20 x 2.5 42 deep
M1341	24 k6	50	5	40	27	8	M8 x 1.25 19 deep	90 m6	170	15	140	95	25	M24 x 3.0 50 deep
M1441	24 k6	50	5	40	27	8	M8 x 1.25 19 deep	100 m6	210	15	180	106	28	M24 x 3.0 50 deep

SERIES M

DIMENSIONS - QUINTUPLE REDUCTION FLANGE MOUNT

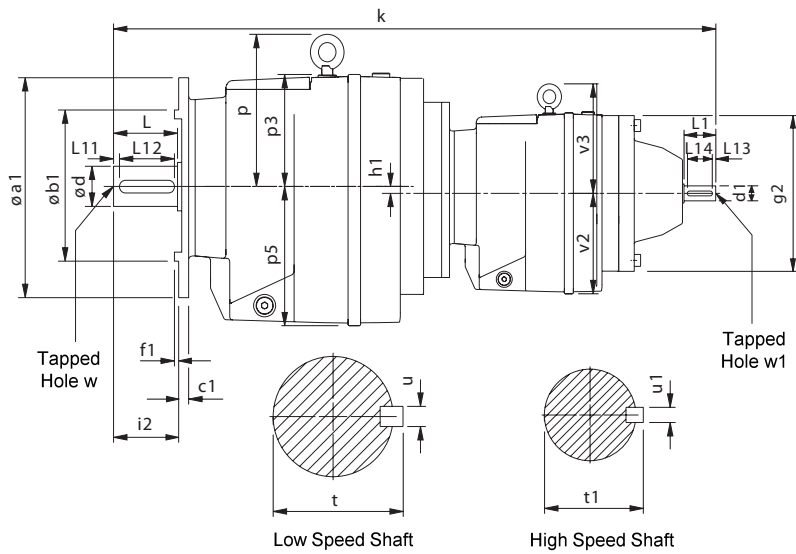

Sizes
3, 4, 5, 6, 7 and 8

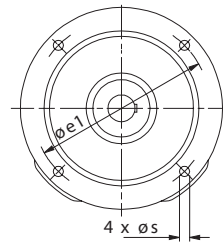

Sizes
9, 10, 13 and 14

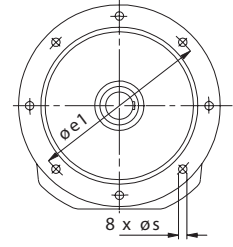

Note: Sizes 03 to 08 are also available as C-Flange (B14) Mounting, please see page 118 for details

Size	$\phi a1$	$\phi b1$	c1	$\phi e1$	f1	$\phi g2$	h1	i2	k	p	p3	p5	s	v2	v3
M0352	120	80	10	100	3	140	-	50	518	-	90	91	6.6	76	-
	140	95	10	115	3			50					9		
	160	110	10	130	3.5			50					9		
	200	130	10	165	3.5			50					11		
M0452	140	95	11	115	3	140	-	60	584	-	93	115	9	91	-
	160	110	11	130	3.5			60					9		
	200	130	11	165	3.5			60					11		
	250	180	11	215	4			60					13.5		
M0552	140	95	11	115	3	140	-	70	594	-	93	115	9	91	-
	160	110	11	130	3.5			70					9		
	200	130	11	165	3.5			70					11		
	250	180	11	215	4			70					13.5		
M0652	200	130	11	165	4	140	14.5	70	615	116	84	130	11	91	-
	250	180	11	215	4			70					13.5		
	300	230	11	265	4			70					13.5		
M0752	200	130	11	165	3.5	140	-	80	651	155	110	140	11	91	-
	250	180	11	215	4			80					13.5		
	300	230	11	265	4			80					13.5		
M0852	300	230	17	265	4	180	-	100	759	180	130	182	13.5	115	-
	350	250	17	300	5			100					17.5		
M0951	450	350	18	400	5	180	-	140	840	198	-	230	18	115	-
M1051	450	350	22	400	5	212	-	140	968	245	-	260	18	140	155
M1351	550	450	25	500	5	212	-	170	1089	288	-	278	18	140	155
M1451	550	450	25	500	5	212	-	210	1204	320	-	318	18	140	155

Size	High Speed shaft							Low Speed shaft						
	d1	L1	L13	L14	t1	u1	w1	d	L	L11	L12	t	u	w1
M0352	16 k6	40	4	32	18	5	M5 x 0.8 12 deep	25 k6	50	4	40	28	8	M10 x 1.5 22 deep
M0452	16 k6	40	4	32	18	5	M5 x 0.8 12 deep	30 k6	60	4	50	33	8	M10 x 1.5 22 deep
M0552	16 k6	40	4	32	18	5	M5 x 0.8 12 deep	35 k6	70	7	60	38	10	M12 x 1.75 28 deep
M0652	16 k6	40	4	32	18	5	M5 x 0.8 12 deep	35 k6	70	7	60	38	10	M12 x 1.75 28 deep
M0752	16 k6	40	4	32	18	5	M5 x 0.8 12 deep	40 k6	80	5	70	43	12	M16 x 2.0 36 deep
M0852	16 k6	40	4	32	18	5	M5 x 0.8 12 deep	50 k6	100	10	80	53.5	14	M16 x 2.0 36 deep
M0951	16 k6	40	4	32	18	5	M5 x 0.8 12 deep	60 m6	120	10	100	64	18	M20 x 2.5 42 deep
M1051	19 k6	40	4	32	21.5	6	M6 x 1.0 16 deep	70 m6	140	15	110	74.5	20	M20 x 2.5 42 deep
M1351	19 k6	40	4	32	21.5	6	M6 x 1.0 16 deep	90 m6	170	15	140	95	25	M24 x 3.0 50 deep
M1451	19 k6	40	4	32	21.5	6	M6 x 1.0 16 deep	100 m6	210	15	180	106	28	M24 x 3.0 50 deep

all parallel keys are to DIN 6885

SERIES M

DIMENSIONS - C-FLANGE (B14) MOUNTING

Column 9 Entry

- E C-Flange (B14) Mounting (For sizes M01 to M08 only)
- V Base and C-Flange (B14) Mounting (non standard - special orders only)

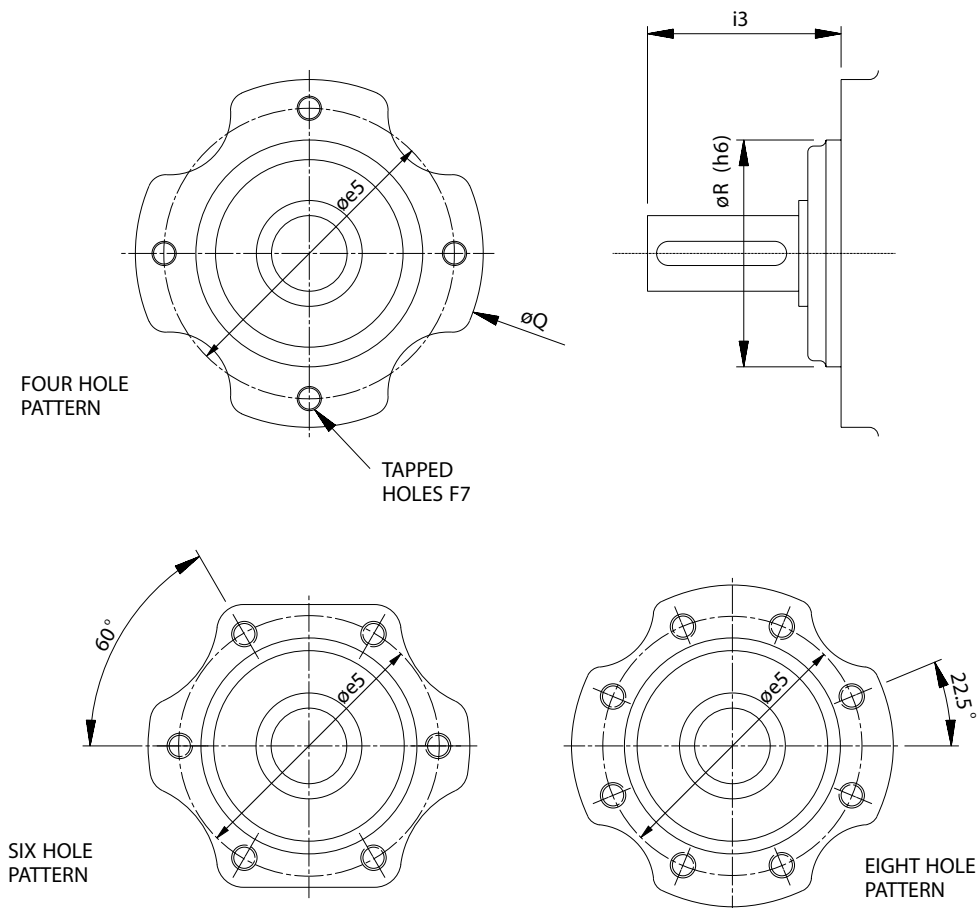

2, 3, 4 & 5 Stage Units

SIZE	Øe5	F7	i3	ØQ	ØR
M01	75 pcd	4 Holes M8 x 1.25 12 Deep	54	98	52
M02 / M03	96 pcd	4 Holes M8 x 1.25 15 Deep	62 / 62	115	75
M04 / M05	105 pcd	4 Holes M12 x 1.75 21 Deep	74 / 84	130	85
M06 / M07	124 pcd	6 Holes M12 x 1.75 21 Deep	84 / 94	152	102
M08	170 pcd	8 Holes M12 x 1.75 21 Deep	120	195	145

SERIES M

THERMAL POWER RATINGS

Thermal Ratings kW

Thermal ratings are a measure of the units ability to dissipate heat, if they are exceeded the lubricant may break down resulting in premature gear failure.

Thermal rating are based on an ambient temperature of 20°C, where units are to operate in other ambient temperatures thermal ratings must be adjusted by the following factors

Unit Size	Ambient Temperature °C							
	-20	-10	0	10	20	30	40	50
All Units	1.57	1.43	1.29	1.14	1.00	0.86	0.71	0.5

Thermal Power (kW) - Two Stage Units

Overall Ratios	Type Of Cooling	Input rev/min	Unit Size											
			M01	M02	M03	M04	M05	M06	M07	M08	M09	M10	M13	M14
1.4 to 5.6	Units with no additional cooling	2900	Consult Application Engineering											
		1450	4.1	6	6	9.9	9.9	11.5	14.5	22	31	42	54	73
		960	4	5.7	5.7	9.5	9.5	11	13.8	21	30	40	51	70
		725	3.9	5.6	5.6	9.2	9.2	10.6	13.4	20	29	39	50	68
6.3 & over	Units with no additional cooling	2900	3	4.4	4.4	7.2	7.2	8.3	10.5	16	23	31	39	53
		1450	4.1	5.8	5.8	9.8	9.8	11.3	14.2	22	31	42	53	72
		960	3.9	5.5	5.5	9.4	9.4	10.8	13.6	21	29	40	50	69
		725	3.8	5.4	5.4	9.1	9.1	10.5	13.1	20	28	38	49	67
1.4 to 5.6	Units with Fan cooling	2900	N/A	N/A	N/A	N/A	N/A	N/A	N/A	N/A	N/A	N/A	N/A	N/A
		1450	-	-	-	-	-	-	29	44	63	85	107	146
		960	-	-	-	-	-	-	25	39	55	74	94	128
		725	-	-	-	-	-	-	22	33	47	63	81	110
6.3 & over	Units with Fan cooling	2900	-	-	-	-	-	-	N/A	N/A	N/A	N/A	N/A	N/A
		1450	-	-	-	-	-	-	28	43	62	83	105	144
		960	-	-	-	-	-	-	25	38	54	73	92	126
		725	-	-	-	-	-	-	21	33	46	62	79	108

Note: When checking thermal capacities use actual load required to be transmitted, not rating of prime mover.

SERIES M

FAN COOLED UNITS

Column 10 Entry

For reducer fan kit modules enter **S** in column 10
 or if used in conjunction with a reducer backstop module kit

Y

CW rotation

Z

CCW rotation

Dimensions of Fan Cooled Units

Double Reduction Units

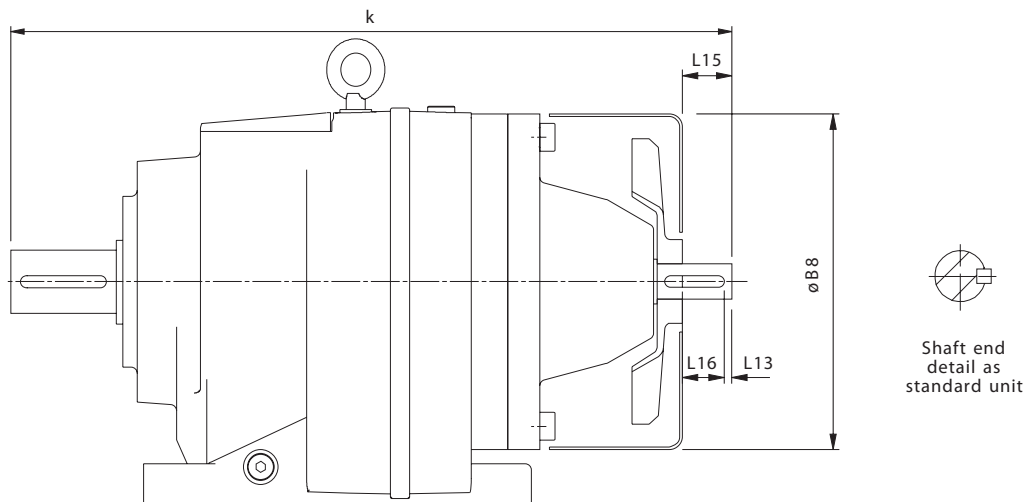

Unit Size	ØB8	k	L13	L15	L16
M0722	225	440	5	35	30
M0822	265	555	5	45	40
M0921	320	660	5	65	60
M1021	380	782	10	95	85
M1321	420	907	10	85	75
M1421	480	1022	10	85	75

SERIES M

REDUCER BACKSTOP MODULE

The reducer units listed below can be fitted with an internal backstop, this has no effect of the external unit size. The backstop device incorporates high quality centrifugal lift off sprags which are wear free above the lift off speed (n min). To ensure correct operation input speed must exceed lift off speed.

Suitable for ambient temperature -40°C to + 50°C

Column 10 Entry

For reducer backstop modules enter W for CCW rotation (or Z if used in conjunction with a fan kit)
 X for CW rotation (or Y if used in conjunction with a fan kit)

Unit Size	Lift off Speed ('n' min) (at inputshaft) (rev/min)	Rated Locking Torque ('T max') (at inputshaft) (Nm)
M0422	800	100
M0522	800	100
M0622	800	100
M0712	670	170
M0722	670	170
M0732	800	100
M0822	670	300
M0832	670	170
M0921	620	940
M0931	670	300
M1021	550	1260
M1031	670	300
M1321	550	2400
M1331	550	2400
M1421	550	2400
M1431	550	2400

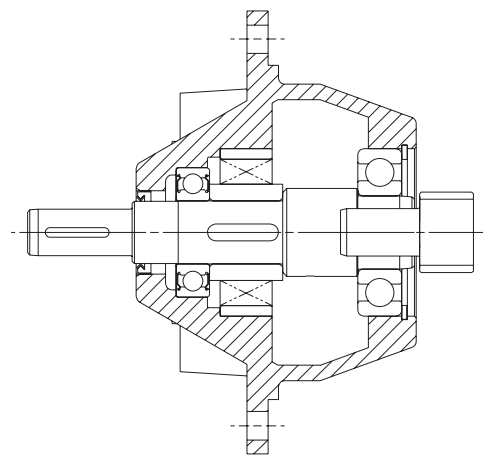

Rotation of outputshaft must be specified when ordering as viewed from the outputshaft end (as shown in the diagram)

CW	-	Free Rotation	-	Clockwise
		Locked	-	Anticlockwise
AC	-	Free Rotation	-	Anticlockwise
		Locked	-	Clockwise

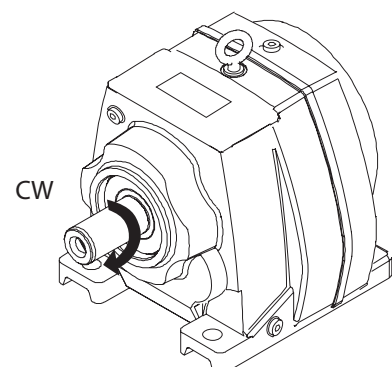

SERIES M

SHIPPING SPECIFICATION

BASE MOUNT UNITS

UNIT SIZE & No OF REDUCTIONS		M0122	M0132	M0222	M0232	M0322	M0332	M0342	M0352	M0422	M0432	M0442	M0452	M0522	M0532	M0542	M0552	M0622	M0632	M0642	M0652	M0722	
REDUCER VERSION		8.2	8.8	12	13	12	13	21.1	21.7	22	22	33	34	22	22	35	36	27	27	40	41	38	
MOTORISED	63	Without Motor	8.9	11	12	14	12	14	22	23		24	36	37		24	36	37		29	41	43	
		With Motor	13	15	17	18	17	18	26	28		28	40	42		28	40	42		33	45	47	
	71	Without Motor	8.5	10	12	14	12	14	21	23		23	35	37		23	35	37		29	41	42	
		With Motor	15	17	19	20	19	20	28	29		30	42	43		30	42	44		35	47	49	
	80A	Without Motor	9.0	12	13	14	13	14	22	23	21	24	36	37	22	24	36	38	27	29	41	43	34
		With Motor	19	21	22	24	22	24	31	33	31	33	45	47	31	33	45	47	36	39	51	52	44
	80B	Without Motor	9.0	12	13	14	13	14	22	23	21	24	36	37	22	24	36	38	27	29	41	43	34
		With Motor	20	23	24	25	24	25	33	34	32	35	47	48	33	35	47	49	38	40	52	54	45
	90S	Without Motor	10	12	13	16	13	15	23	24	22	24	37	38	23	25	37	38	28	30	42	44	35
		With Motor	23	25	27	30	27	28	36	38	36	38	50	52	36	38	50	52	41	43	55	57	48
	90L	Without Motor	10	12	13	16	13	15	23	24	22	24	37	38	23	25	37	38	28	30	42	44	35
		With Motor	24	26	28	31	28	29	37	39	37	39	51	53	37	39	51	53	42	44	56	58	49
	100L	Without Motor	12		15		15				25				25				31				38
		With Motor	36		39		39				49				51				54				62
	112M	Without Motor	12		15		15				25				25				31				38
		With Motor	43		46		46				56				56				62				69
	132S	Without Motor																					40
		With Motor																					88
	132M	Without Motor																					40
		With Motor																					92
	160M	Without Motor																					
		With Motor																					
	160L	Without Motor																					
		With Motor																					

SERIES M

SHIPPING SPECIFICATION

BASE MOUNT UNITS

UNIT SIZE & No OF REDUCTIONS		M0732	M0742	M0752	M0822	M0832	M0842	M0852	M0921	M0931	M0941	M0951	M1021	M1031	M1041	M1051	M1321	M1331	M1341	M1351	M1421	M1431	M1441	M1451	
REDUCER VERSION		39	48	49	67	74	96	96	114	123	140	140	170	179	204	206	248	270	279	280	360	405	395	396	
MOTORISED	80A	Without Motor	39	48	52	73	71	96	99	117	127	145	148		182	194	199			336	342			446	452
		With Motor	49	57	61	82	81	106	108	127	137	154	157		192	203	209			346	351			456	461
	80B	Without Motor	39	48	52	73	71	96	99	117	127	145	148		182	194	199			336	342			446	452
		With Motor	50	59	63	84	82	107	110	128	138	156	159		193	205	210			347	353			457	463
	90S	Without Motor	40	48	52	73	72	97	100	117	127	145	149		182	194	200			337	342			445	450
		With Motor	53	62	66	86	85	110	113	131	141	159	162		196	208	213			350	356			458	464
	90L	Without Motor	40	48	52	73	72	97	100	117	127	145	149		182	194	200			337	342			445	450
		With Motor	54	63	67	87	86	111	114	132	142	160	163		197	209	214			351	357			459	465
	100L	Without Motor	39			73	75	97		117	127	145		163	182	197	203	239	271	340	345	344	394	450	455
		With Motor	63			97	99	121		141	151	169		187	206	221	227	263	295	364	369	368	418	474	479
	112M	Without Motor	43			73	75			117	127			163	182	197	203	239	271	340	345	344	394	450	455
		With Motor	74			104	106			148	158			194	213	228	234	270	302	371	376	375	425	481	486
	132S	Without Motor				72				117				163	182	199		239	271	342	347	344	394	452	
		With Motor				120				165				211	230	247		287	319	390	395	392	442	500	
	132M	Without Motor				72				117				163	182	199		239	271	342	347	344	394	452	
		With Motor				124				169				215	234	251		291	323	394	399	396	446	504	
	160M	Without Motor				72				124				172	189			247	279			357	402		
		With Motor				153				205				253	270			328	360			438	483		
	160L	Without Motor				72				124				172	189			247	279			357	402		
		With Motor				167				219				267	284			342	374			452	497		
	180M	Without Motor								124				172	189			247	279			357	402		
		With Motor								291				339	356			414	446			524	569		
	180L	Without Motor								124				172	189			247	279			357	402		
		With Motor								305				353	370			428	460			538	583		
	200L	Without Motor								124				172				247	279			357	402		
		With Motor								356				404				479	511			589	634		
	225S	Without Motor								138				186				261	293			371	416		
		With Motor								425				473				548	580			658	703		
225M	Without Motor								138				186				261	293			371	416			
	With Motor								460				508				583	615			693	738			
250M	Without Motor																310				420				
	With Motor																695				805				
280S	Without Motor																310				420				
	With Motor																820				930				
280M	Without Motor																310				420				
	With Motor																910				1020				

IMPORTANT

Product Safety Information

General - The following information is important in ensuring safety. It **must** be brought to the attention of personnel involved in the selection of the equipment, those responsible for the design of the machinery in which it is to be incorporated and those involved in its installation, use and maintenance.

The equipment will operate safely provided it is selected, installed, used and maintained properly. As with any power transmission equipment **proper precautions must** be taken as indicated in the following paragraphs, to ensure safety.

Potential Hazards - these are **not** necessarily listed in any order of severity as the degree of danger varies in individual circumstances. It is important therefore that the list is studied in its entirety:-

- 1) Fire/Explosion
 - (a) Oil mists and vapour are generated within gear units. It is therefore dangerous to use naked lights in the proximity of gearbox openings, due to the risk of fire or explosion.
 - (b) In the event of fire or serious overheating (over 300 °C), certain materials (rubber, plastics, etc.) may decompose and produce fumes. Care should be taken to avoid exposure to the fumes, and the remains of burned or overheated plastic/rubber materials should be handled with rubber gloves.
- 2) Guards - Rotating shafts and couplings must be guarded to eliminate the possibility of physical contact or entanglement of clothing. It should be of rigid construction and firmly secured.
- 3) Noise - High speed gearboxes and gearbox driven machinery may produce noise levels which are damaging to the hearing with prolonged exposure. Ear defenders should be provided for personnel in these circumstances. Reference should be made to the Department of Employment Code of Practice for reducing exposure of employed persons to noise.
- 4) Lifting - Where provided (on larger units) only the lifting points or eyebolts must be used for lifting operations (see maintenance manual or general arrangement drawing for lifting point positions). Failure to use the lifting points provided may result in personal injury and/or damage to the product or surrounding equipment. Keep clear of raised equipment.
- 5) Lubricants and Lubrication
 - (a) Prolonged contact with lubricants can be detrimental to the skin. The manufacturer's instruction must be followed when handling lubricants.
 - (b) The lubrication status of the equipment must be checked before commissioning. Read and carry out all instructions on the lubricant plate and in the installation and maintenance literature. Heed all warning tags. Failure to do so could result in mechanical damage and in extreme cases risk of injury to personnel.
- 6) Electrical Equipment - Observe hazard warnings on electrical equipment and isolate power before working on the gearbox or associated equipment, in order to prevent the machinery being started.
- 7) Installation, Maintenance and Storage
 - (a) In the event that equipment is to be held in storage, for a period exceeding 6 months, prior to installation or commissioning, application engineering must be consulted regarding special preservation requirements. Unless otherwise agreed, equipment must be stored in a building protected from extremes of temperature and humidity to prevent deterioration.
The rotating components (gears and shafts) must be turned a few revolutions once a month (to prevent bearings brinelling).
 - (b) External gearbox components may be supplied with preservative materials applied, in the form of a "waxed" tape overwrap or wax film preservative. Gloves should be worn when removing these materials. The former can be removed manually, the latter using white spirit as a solvent.

Preservatives applied to the internal parts of the gear units do not require removal prior to operation.
 - (c) Installation must be performed in accordance with the manufacturer's instructions and be undertaken by suitably qualified personnel.
 - (d) Before working on a gearbox or associated equipment, ensure that the load has been removed from the system to eliminate the possibility of any movement of the machinery and isolate power supply. Where necessary, provide mechanical means to ensure the machinery cannot move or rotate. Ensure removal of such devices after work is complete.
 - (e) Ensure the proper maintenance of gearboxes in operation. Use only the correct tools and approved spare parts for repair and maintenance. Consult the Maintenance Manual before dismantling or performing maintenance work.
- 8) Hot Surfaces and Lubricants
 - (a) During operation, gear units may become sufficiently hot to cause skin burns. Care must be taken to avoid accidental contact.
 - (b) After extended running the lubricant in gear units and lubrication systems may reach temperatures sufficient to cause burns. Allow equipment to cool before servicing or performing adjustments.
- 9) Selection and Design
 - (a) Where gear units provide a backstop facility, ensure that back-up systems are provided if failure of the backstop device would endanger personnel or result in damage.
 - (b) The driving and driven equipment must be correctly selected to ensure that the complete machinery installation will perform satisfactorily, avoiding system critical speeds, system torsional vibration, etc.
 - (c) The equipment must not be operated in an environment or at speeds, powers, torques or with external loads beyond those for which it was designed.
 - (d) As improvements in design are being made continually the contents of this catalogue are not to be regarded as binding in detail, and drawings and capacities are subject to alterations without notice.

The above guidance is based on the current state of knowledge and our best assessment of the potential hazards in the operation of the gear units.

Any further information or clarification required may be obtained by contacting an Application Engineer.

AUSTRALIA

David Brown Gear Industries Ltd
13-19 Franklin Avenue
Bulli, NSW 2516
Australia

Tel: +61 2 4283 0300
Fax: +61 2 4283 0333

CHINA

David Brown Gear Systems Trading (Shanghai) Co. Ltd
No. 218 Xi Zhang South Road,
Silver Tower, Suite 1204B
Shanghai 200021 P.R.China

Tel: +86 21 6334 3322
Fax: +86 21 53966 913

DENMARK

Benzler Transmission A/S
Fuglebævej 3D
DK-2770 Kastrup,
Danmark

Tel: +45 36 34 03 00
Fax: +45 36 77 02 42

EUROPE

Benzler TBA BV
Jachthavenweg 2
NL-5928 NT Venlo

Netherlands & the rest of Europe
Tel: +31 77 324 59 00
Fax: +31 77 324 59 01

Austria
Tel: +43 7 229 618 91
Fax: +43 7 229 618 84

Germany
Tel: 0800 350 40 00
Fax: 0800 350 40 01

FINLAND

Oy Benzler AB
Vanha Talvitie 3C
FI-00580 Helsingfors,
Finland

Tel: +358 9 340 1716
Fax: +358 9 340 1761

FRANCE

WECO Transmissions SA

Tel: +333 8937 0113
Fax: +333 8937 3936

ITALY

David Brown Hydraulics Italia S.R.L.
Via Del Costruttore, 64
41058 – Vignola (MO)
Italy

Tel: +39 059 770 0411
Fax: +39 059 770 0425

SOUTH AFRICA

David Brown Gear Industries Ltd
12 Birmingham Street,
Benoni Industrial
1500
South Africa

Tel: +27 11 748 0000
Fax: +27 11 421 2553

SWEDEN & NORWAY

AB Benzlers
Box 922 (Landskronavägen 1)
251 09 Helsingborg
Sweden

Tel: +46 42 18 68 00
Fax: +46 42 21 88 03

THAILAND

David Brown (Thailand) Ltd
700/43 Moo 6
Amata Nakorn Industrial Estate
Tumbol Klongtumru
Muang,
Chonburi
20000
Thailand

Tel: +66 3845 9044
Fax: +66 3821 3655

UNITED KINGDOM

David Brown Gear Systems Ltd
Park Road
Lockwood, Huddersfield
West Yorkshire, HD4 5DD

Tel: +44 (0) 1484 465 610
Fax: +44 (0) 1484 465 586

USA

Cone Drive
240 East 12th Street
Traverse City
Michigan
49684
USA

Tel: +1 888 994 2663
Fax: +1 888 907 2663

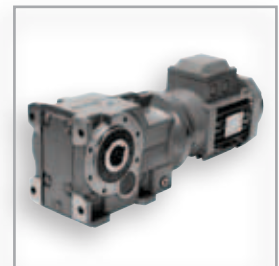
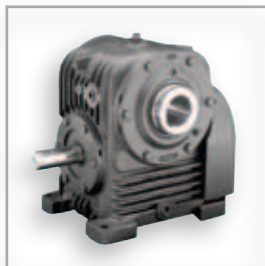
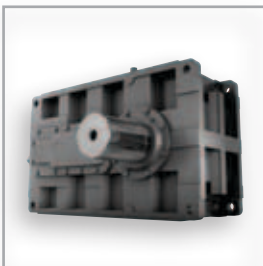
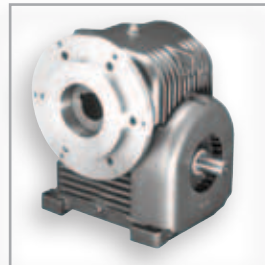
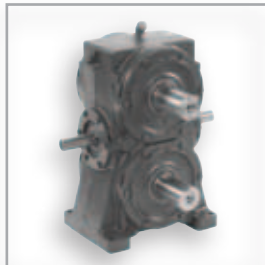
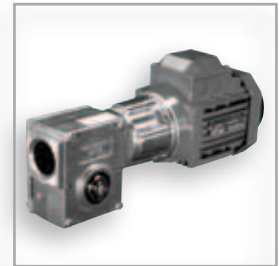
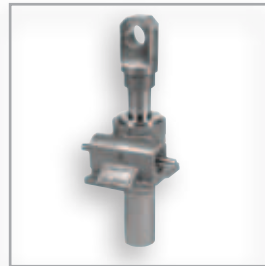

David Brown

Africa +27 11 748 0000
Australia +61 2 4283 0300
China +86 21 5396 6360
Europe +33 3 89 37 01 13
Thailand +66 38 459044
United Kingdom +44 01484 465500

Cone Drive & Benzlers

Central & South America +1 231 946 8410
North America +1 888 994 2663
Scandinavia +46 42 18 68 00

ООО "Компания промышленных деталей"

+38 098 083-58-09
03680 Украина, Киев, ул. Семьи Сосниных, 9
<http://motor-reduktor.com.ua>
misha@motor-reduktor.com.ua

BENZLERS



DAVID BROWN